

**DANCOVER<sup>®</sup>**

**.com**

Manual  
for  
Orangery w/Base  
2,84x2,15x2,43m

# Assembly Instructions

Product Size(WxLxH):2,84x2,15x2,43m

Please read carefully before assembly!

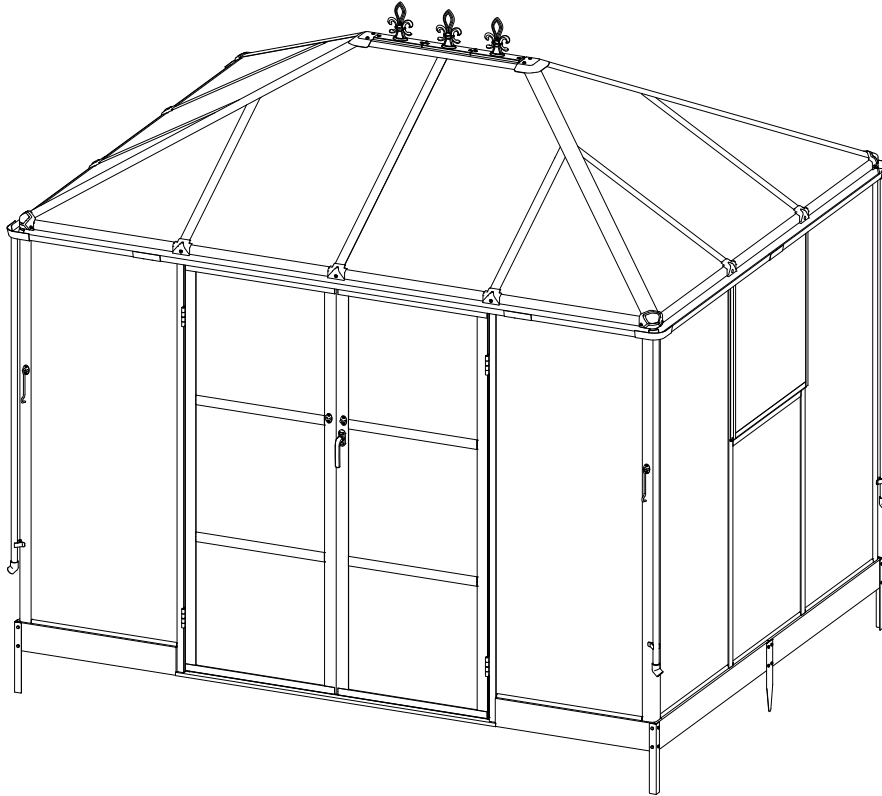

# Contents

1. Assembly advice.....	Page 1
2. Product features.....	Page 2
3. Parts list.....	Page 3-6
4. Base assembly.....	Page 7-10
5. Framework & Board assembly.....	Page 11-37
6. Vent window assembly.....	Page 38-42
7. Door assembly.....	Page 43-51
8. Accessory assembly.....	Page 52-54
9. Rivet nut tools instruction.....	Page 55-56

# Assembly and maintenance advice

1. For safety purposes, we strongly recommend that this product assembled by at least four people.
2. Please be careful the sharp edge when handling metal components. And please wear gloves, shoes and safety goggle during assembly.
3. Lay all of the components on a soft carpet or blanket to avoid any scratches or damages.
4. DO NOT climb or stand on the roof. And heavy articles should not be leaned against the greenhouse.
5. Keep the roof and gutter clear of snow, dirt & leaves. Allowing snow to build up on the roof may damage the product.
6. Unlike steel, if the paint finish is scratched this will not harm the aluminium nderneath.
7. When the product needs to be cleaned, use a mild detergent solution and rinse with cold clean water. Do not use acetone, abrasive cleaners or strong detergents to clean the boards.
8. Tools required when assembly(Not provided).

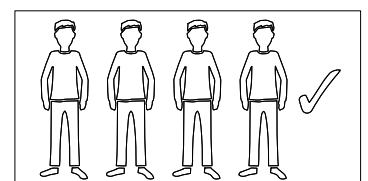
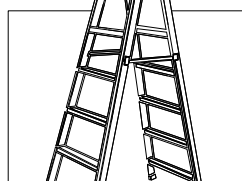
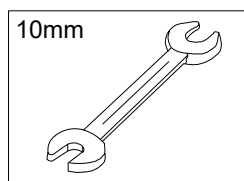
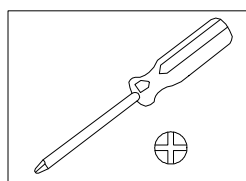
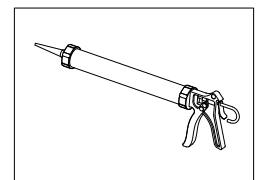
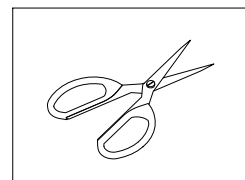
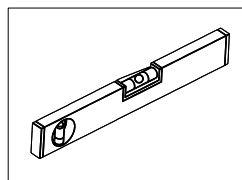
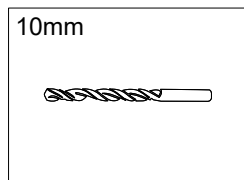
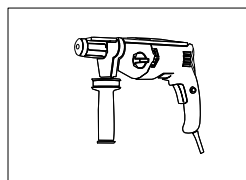
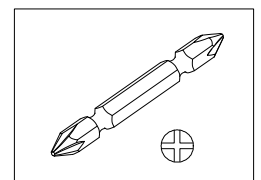
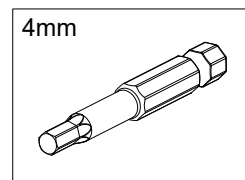
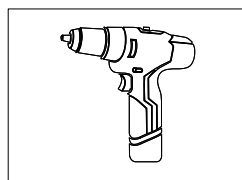
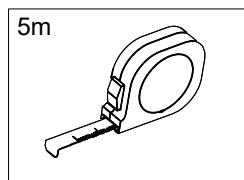
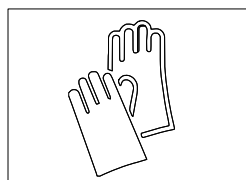

9. Assembly at least by Four persons lasts for 4~6 hours.

# Functions and Features

1. Quick and easy installation profits from the application of rivet nut. So we needn't install nuts.

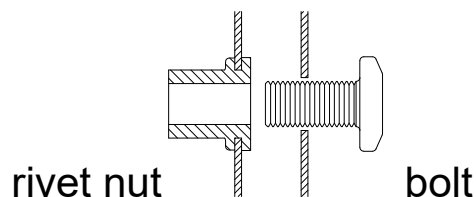

2. Downpipes are included as standard so you can collect rainwater.

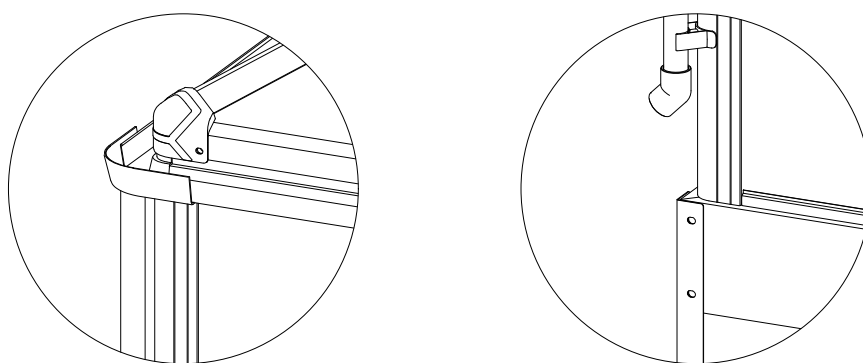

3. Remove film from all boards before installing them. Please ensure that the side with the white film faces outwards.

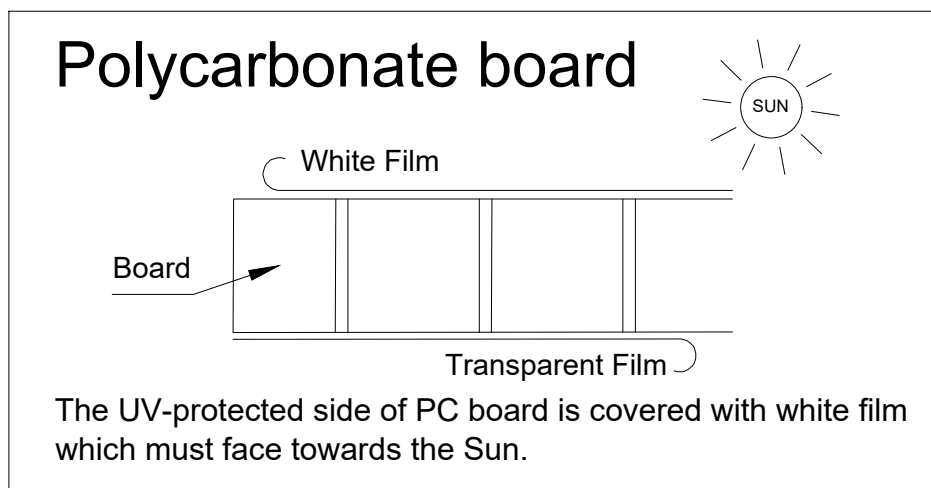



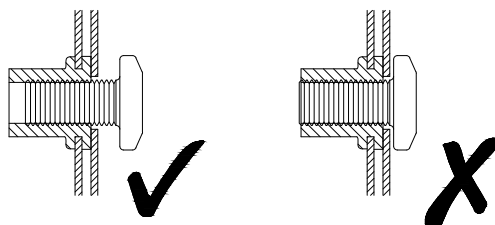

4. Unless otherwise stated ,bolts not to be tightened untile finish assembly!

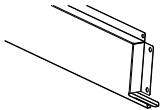
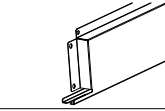
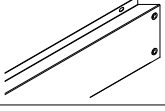
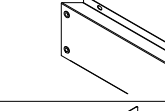
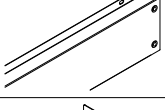
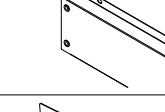
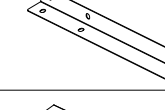
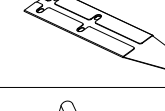
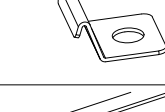
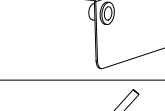
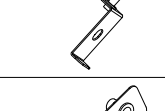
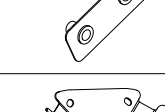
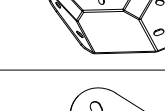
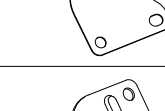

# Part List

## 1.1 Framework list

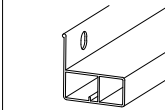
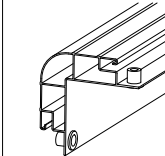
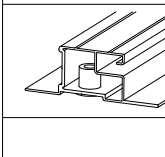
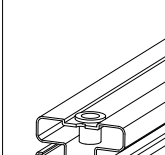
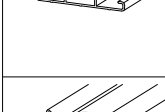
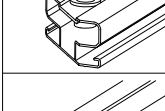
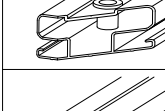
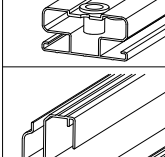
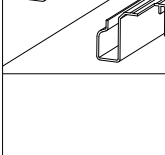
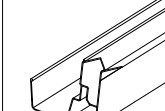
Part	Label	Qty	LEN(mm)
	Z1	1	767.5
	Z2	1	767.5
	Z3	2	1073.5
	Z4	2	1073.5
	Z3A	1	1432
	Z6A	1	1401
	B4	4	300
	B5	3	300
	B9	16	/
	Z8	1	1323
	Z9	4	/
	Z11	6	/
	B12	2	/
	B13	4	/
	B14S	8	/





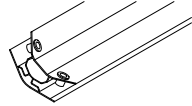
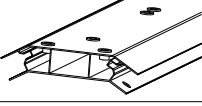
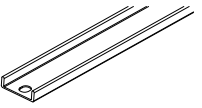
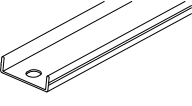
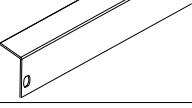
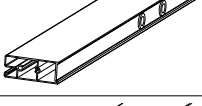
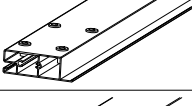
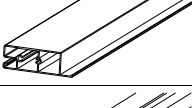
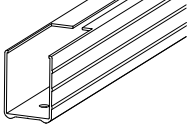
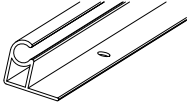
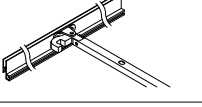
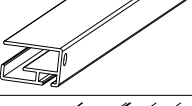
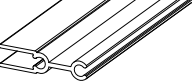

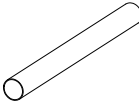
Part	Label	Qty	LEN(mm)
	A1	1	1416
	Z5	1	1670
	Z6	1	1670
	Z12	2	1670
	Z13	1	1776.5
	Z14	1	1776.5
	Z7	2	1154
	Z16	4	1670
	Z17	3	1670
	Z18	2	645
	Z19	2	645
	Z20	4	795
	Z21	4	795
	Z23	4	569
	A14	4	643
	A15	8	643
	Z8A	2	562
	Z9A	2	562
	Z10	2	1040
	Z11A	2	1040
	Z25	2	1642
	Z28	6	200
	A21	6	120

## 1.2 Framework list

Part	Label	Qty	LEN(mm)
	Z12A	4	1511
	Z13A	1	734
	A10	2	648
	A11	2	703
	A27	4	725.5
	A29S	1	1362
	A30	2	1388
	A12	1	1362
	A13	2	659.5
	A31	6	1345.5
	Z33	2	1736
	Z34	1	1736
	Z35	1	1736
	A35	2	660.5
	A36	1	660.5
	A37	1	660.5
	A38	2	705
	Z37	2	721
	A40	4	665
	A41	2	705



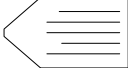
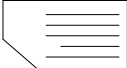
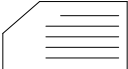

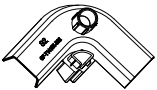

Part	Label	Qty	LEN(mm)
	A43	4	1400

## 2. Boards list

Part	Label	Qty	Size(mm)
	N1	10	1680x667x2
	N2	2	946x667x2
	N3	2	703x647x2
	N4	6	589x568x2
	P1	2	1173x667x4
	P2	2	1176x667x4
	P3	2	1176x667x4
	P4	4	806x675x4
	P5	4	806x675x4

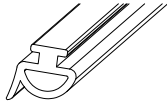
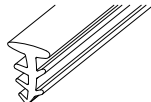
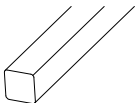
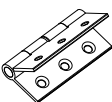
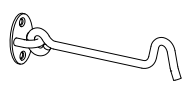

### 3. Accessories list

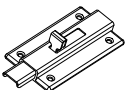
Part	Label	Qty	Size(mm)
	F1	226	M6x12
	F2	16	M6x12
	F3	16	M4x12
	F4	28	ST4.2x10
	F5	8	ST4.2x13
	F6	6	ST3.5x16
	F7	16	M6x60
	S2	4	/
	S3	4	/
	S4	4	/
	S6	3	/
	S7	2	/
	S8	4	/

Part	Label	Qty	Size(mm)
	S9	10	/
	S10	4	/
	S11	2	/
	2028S	4	1"
	T1	1	4m
	T3	2	32m
	T4	1	3m
	T5	4	/
	T6	2	/
	T7	2	/
	T8	1	/
	T9	2	/

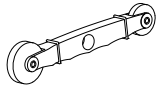
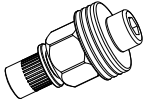
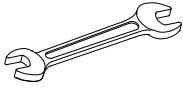
## 4. Tool list

Part	Label	Qty	Size(mm)
	T10	1	/
	T11	1	/
	T12	1	14mm

Part	Label	Qty	Size(mm)
	T13	1	5mm
		5	M6

## 5. Boards Exploded View

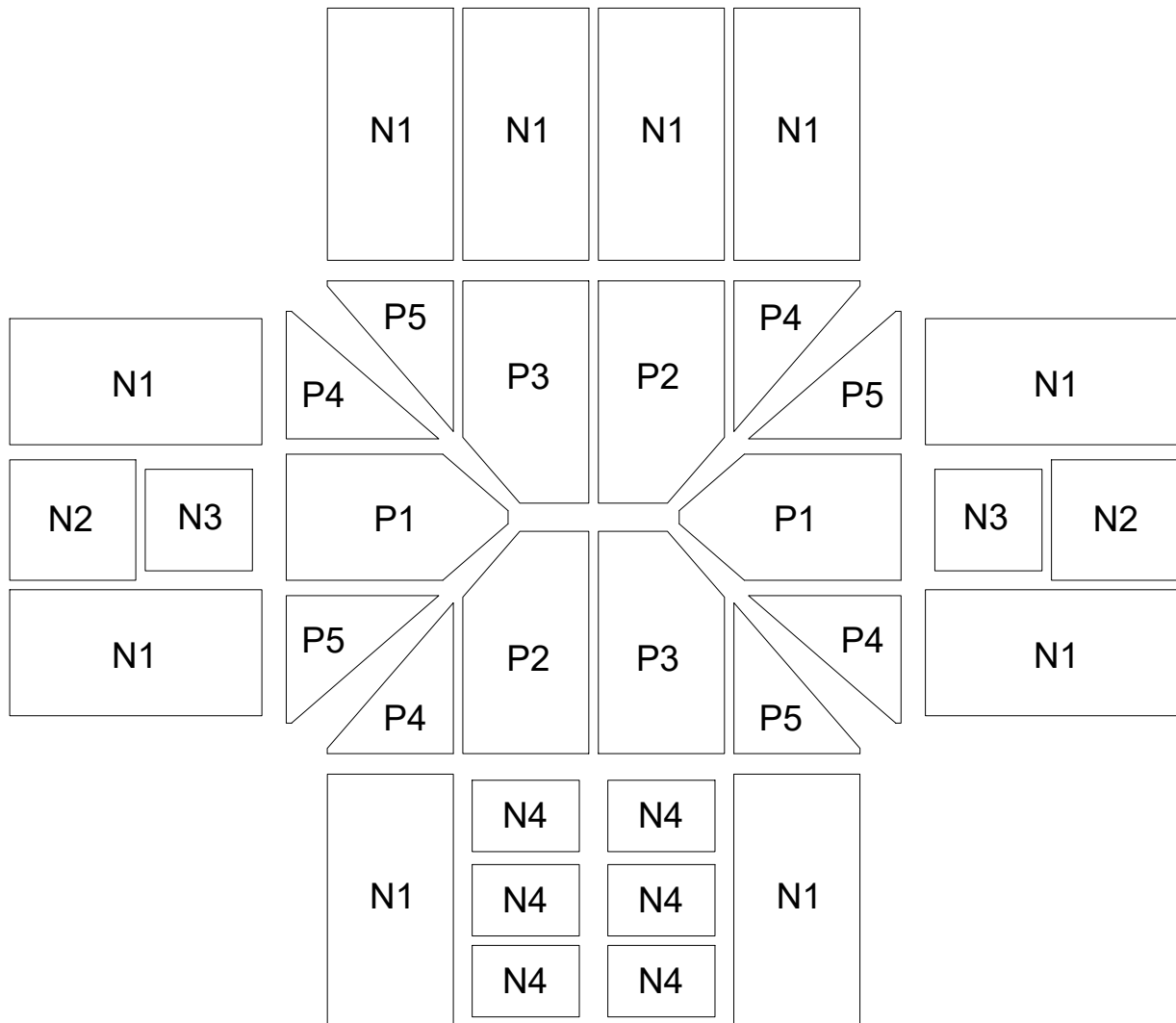

Part	Label	Qty
	Z1	1
	Z2	1
	Z3	2
	Z4	2
	Z3A	1
	Z6A	1
	B4	4
	B5	3
	A1	1
	F1 M6X12	28

(Soil ground) **Base assembly**

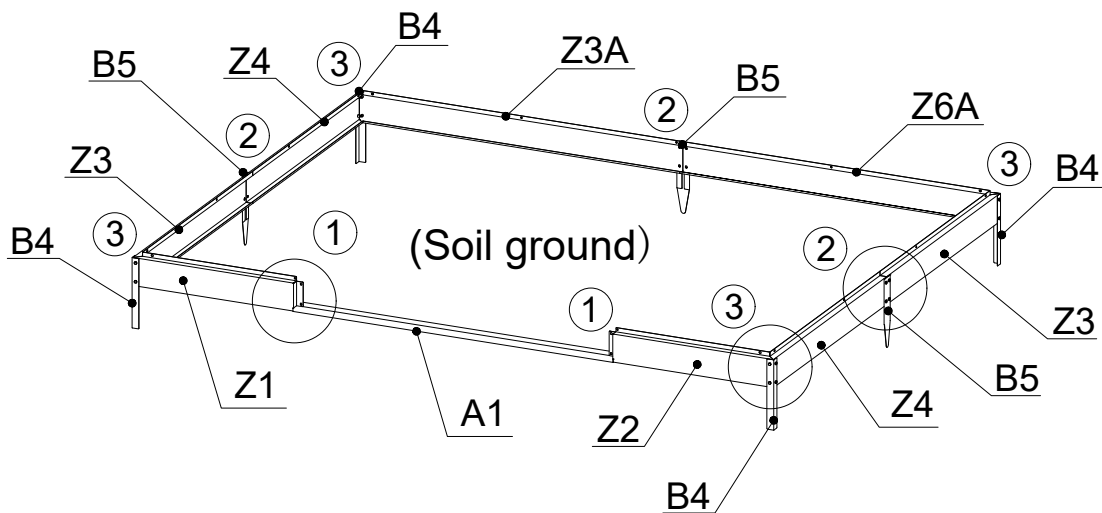
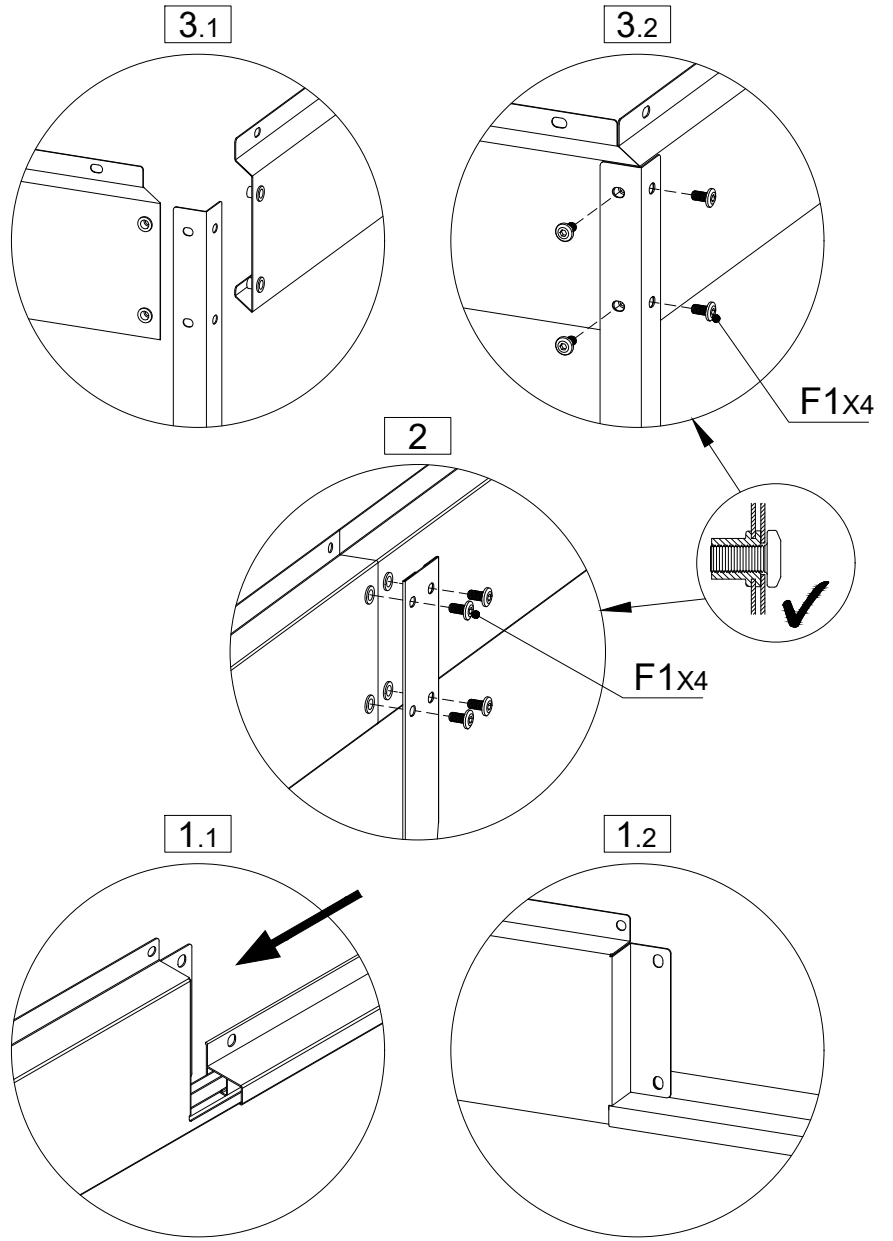

It is impreative that the greenhouse base is leveled!

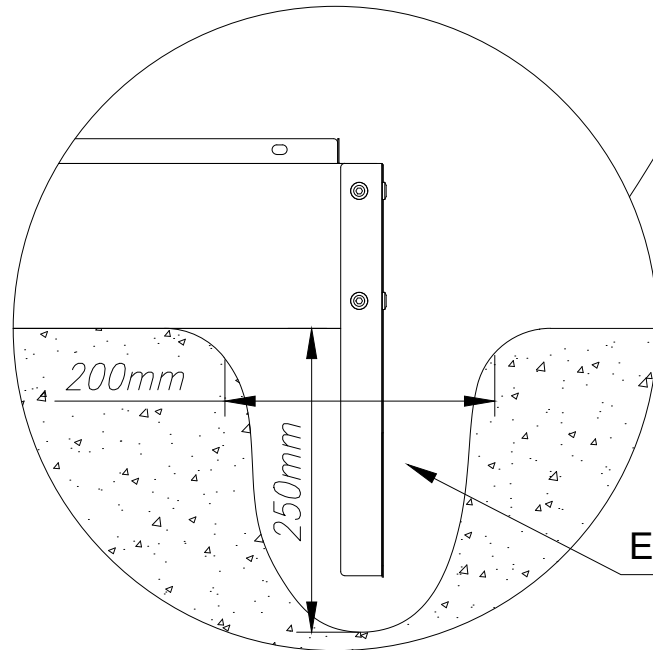
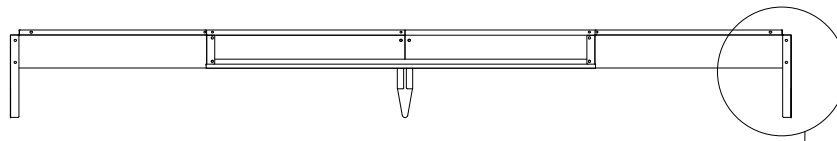
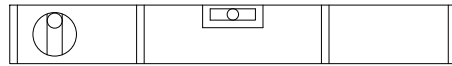

Earth or concrete filling

Keep straight

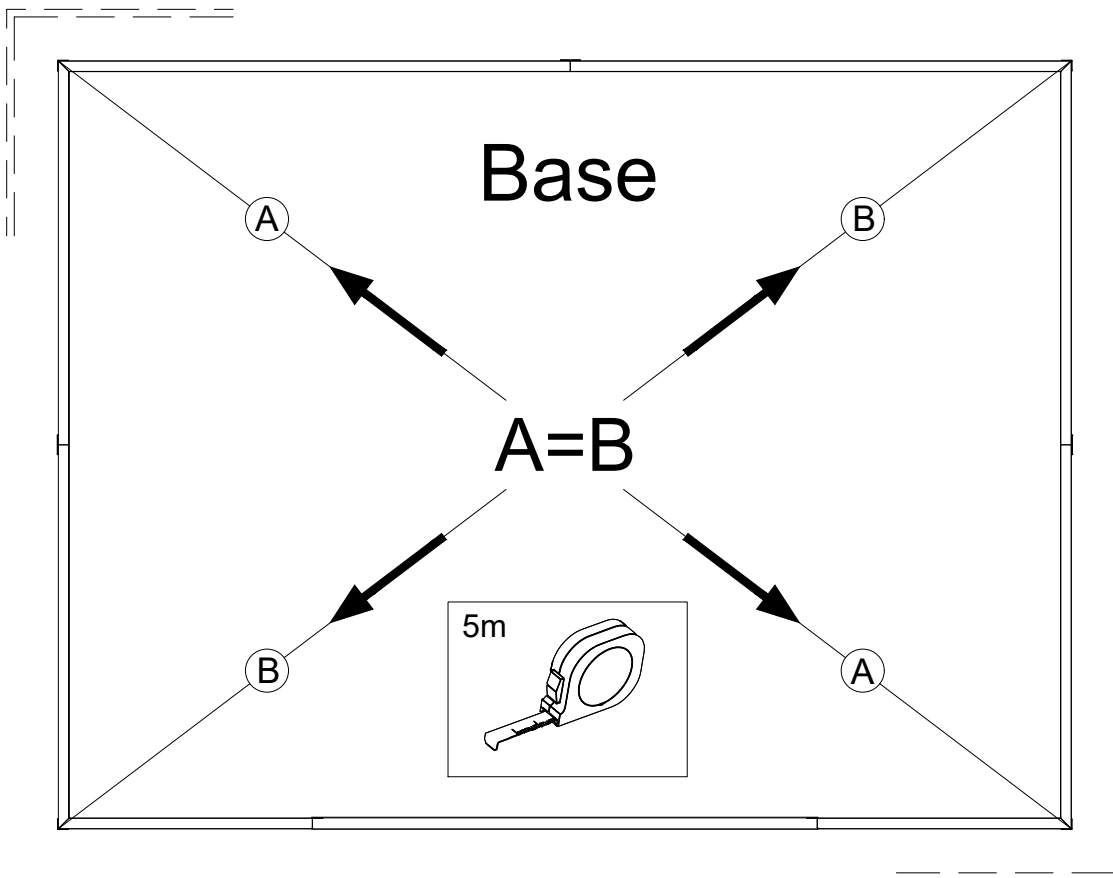

Keep straight

Part	Label	Qty
	Z1	1
	Z2	1
	Z3	2
	Z4	2
	Z3A	1
	Z6A	1
	B4	4
	B5	3
	A1	1
	F1 M6X12	28

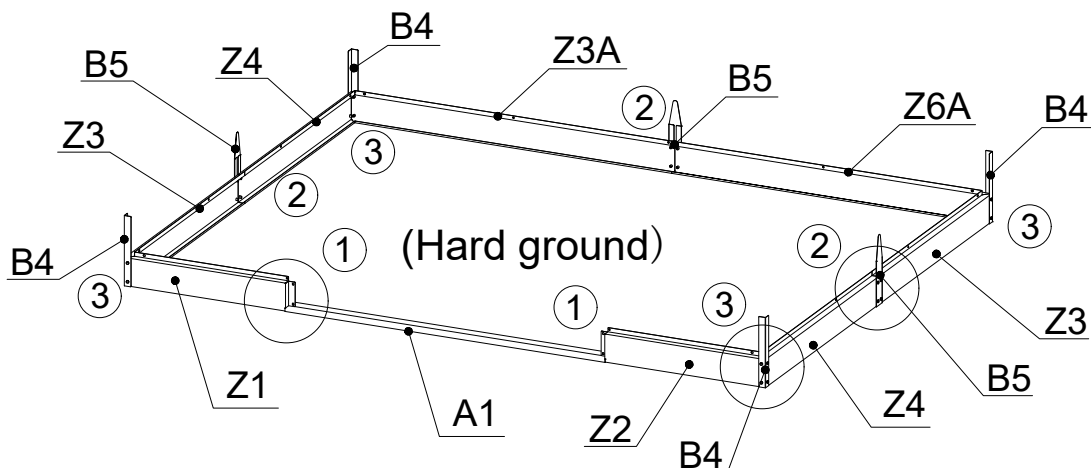
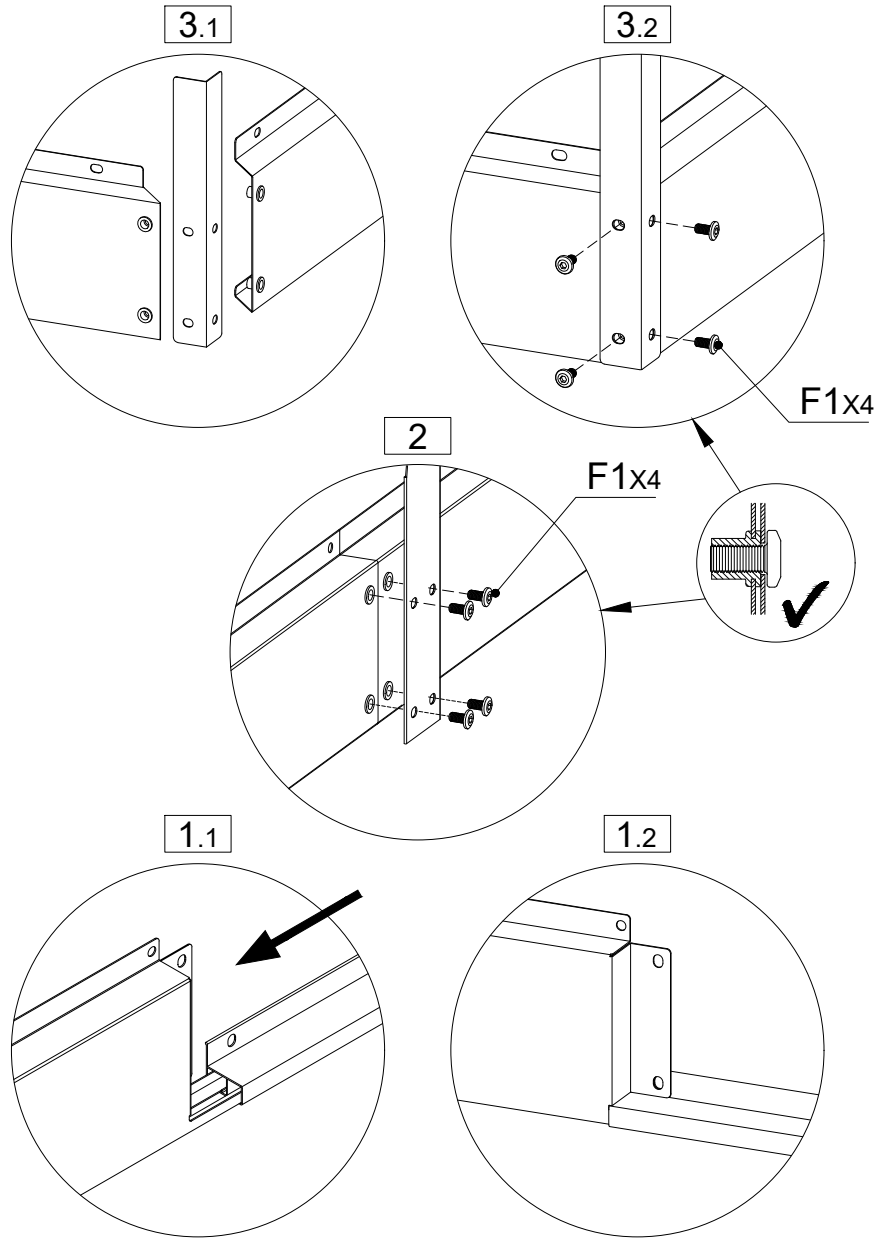

# (Hard ground) Base assembly

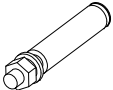

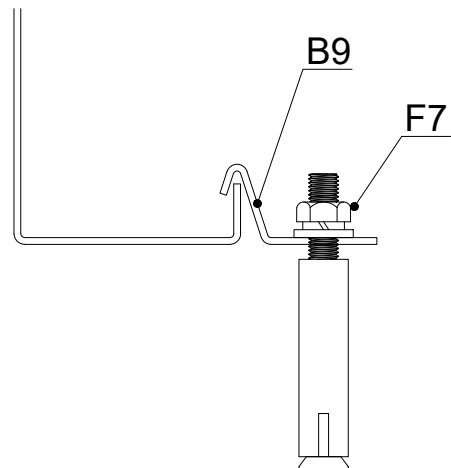
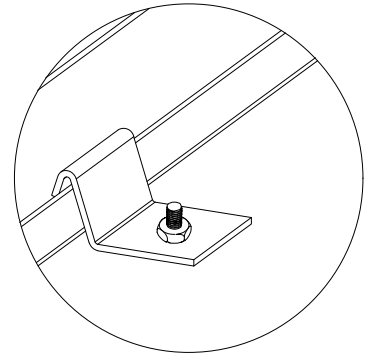
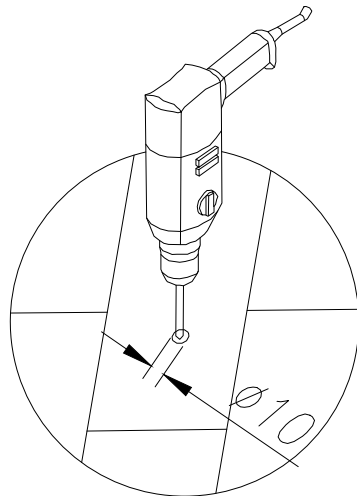
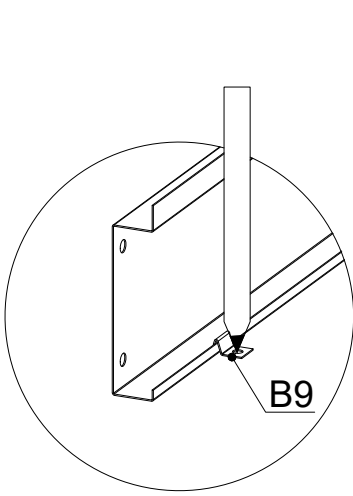
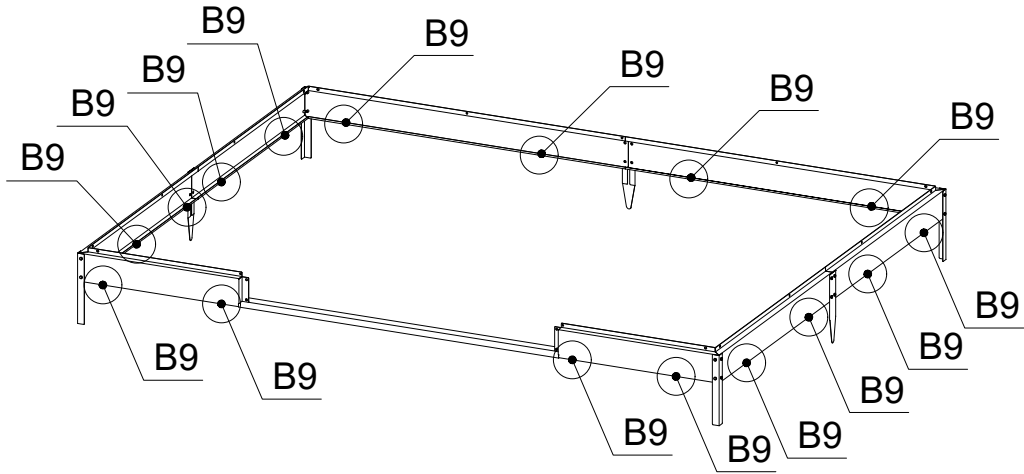
Part	Label	Qty
	B9	16
	F7	16



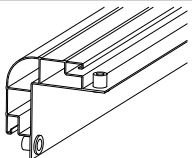
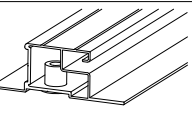

# Framework assembly

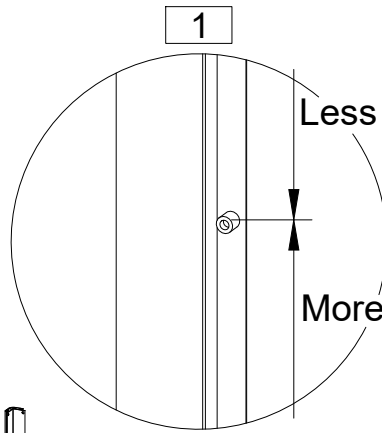
Part	Label	Qty
	Z5	1
	Z6	1
	Z12	2
	Z13	1
	Z14	1
	F1	14
	M6X12	

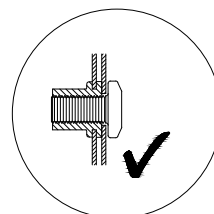
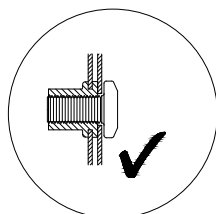
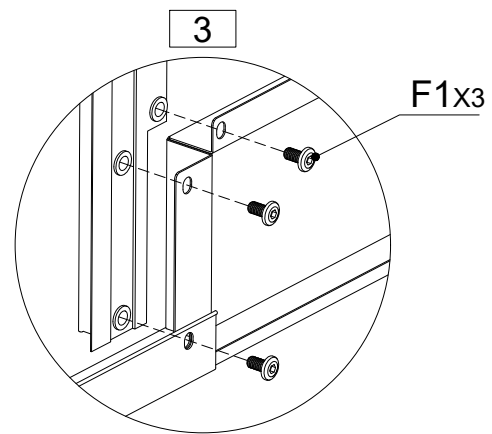
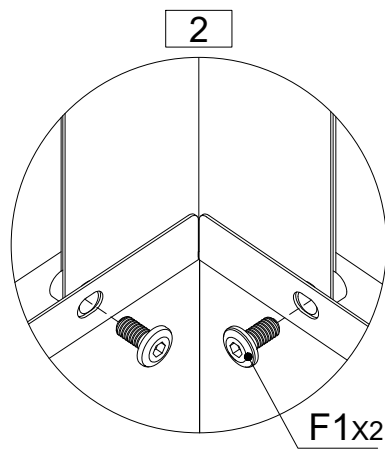
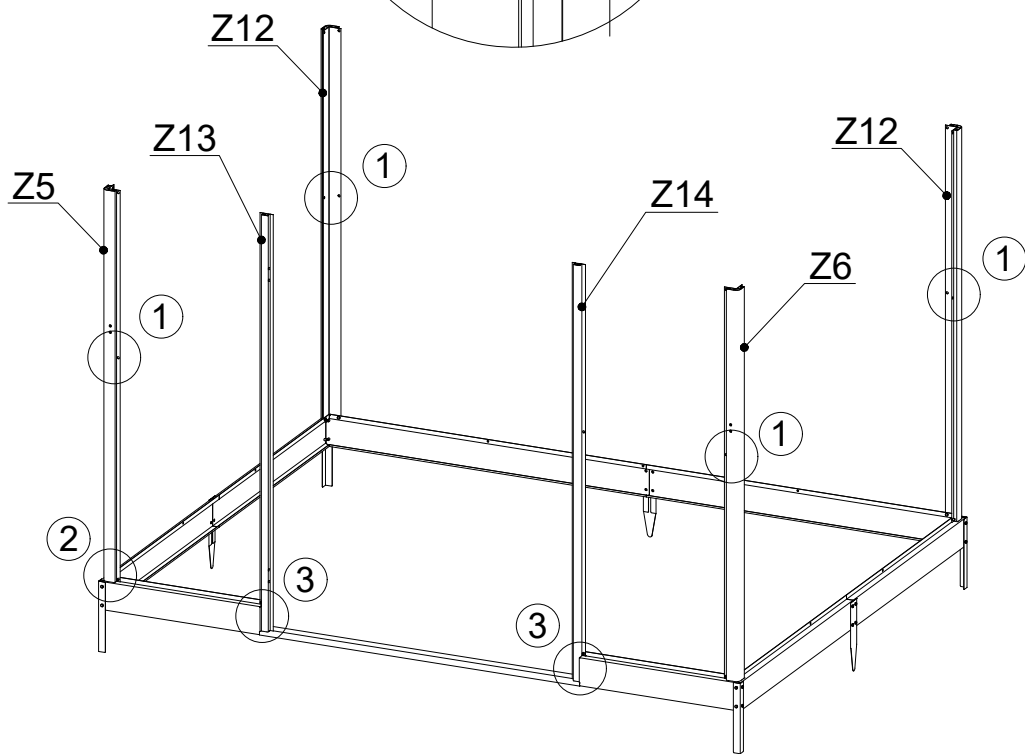

Hole position biased upwards

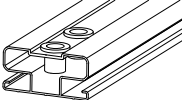
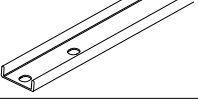

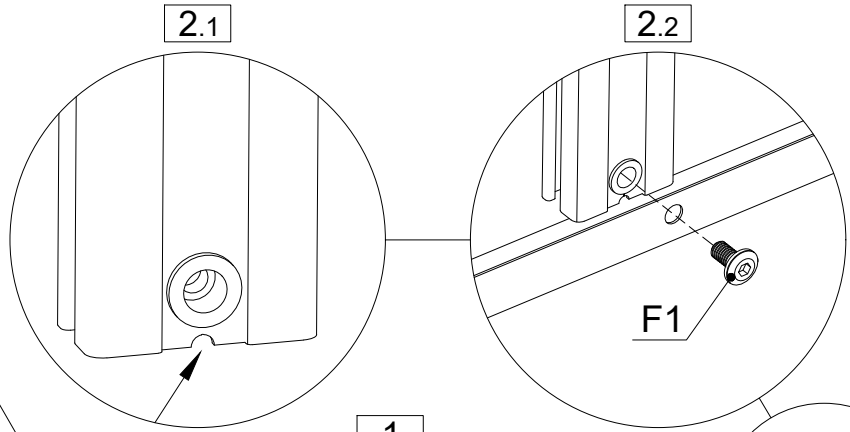

Part	Label	Qty
	Z16	4
	A27	4
	F1 M6X12	12



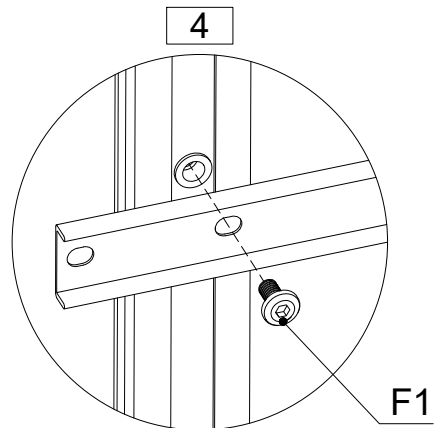
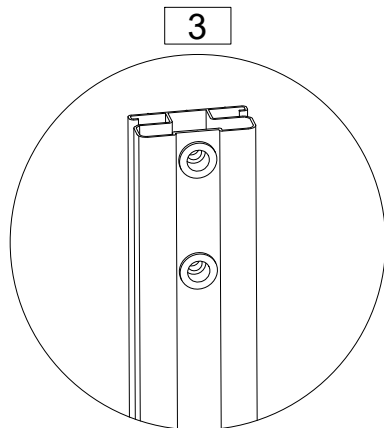
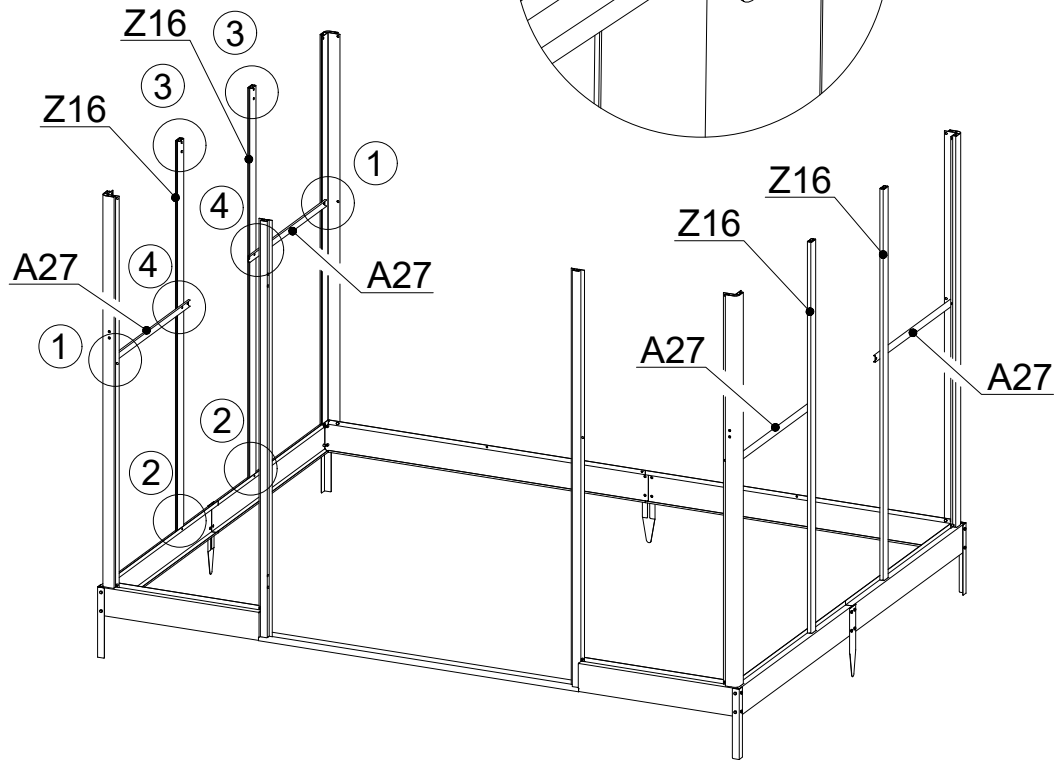
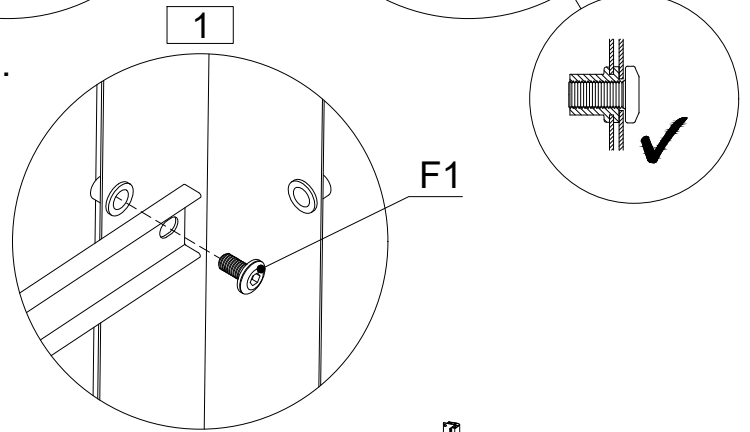

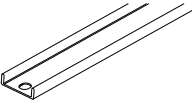

The little gap faces downwards.

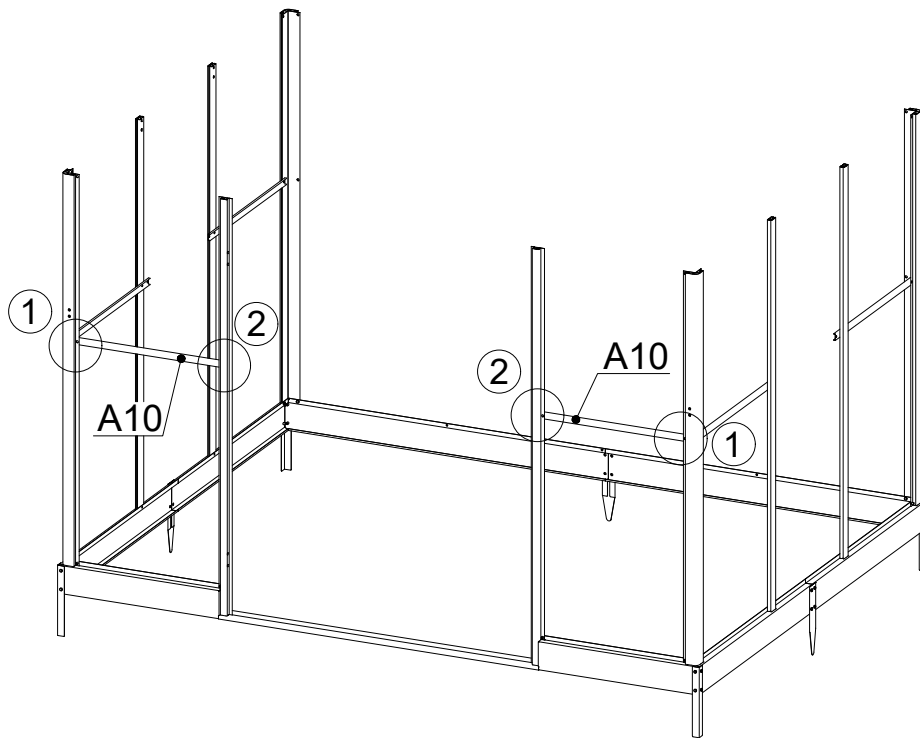
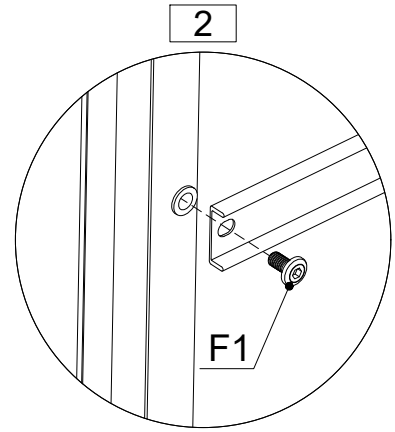
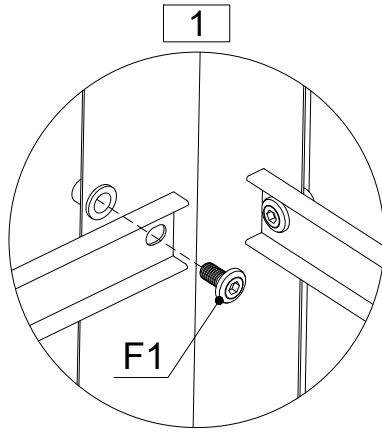

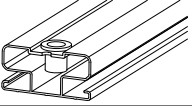
Part	Label	Qty
	A10	2
	F1 M6X12	4

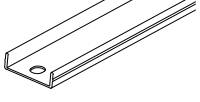

Part	Label	Qty
	Z17	3
	A29S	1
	A12	1
	F1	8
	M6X12	

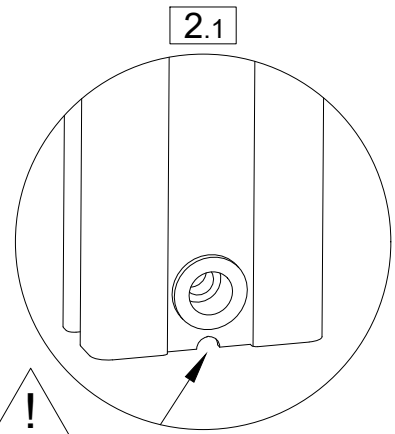
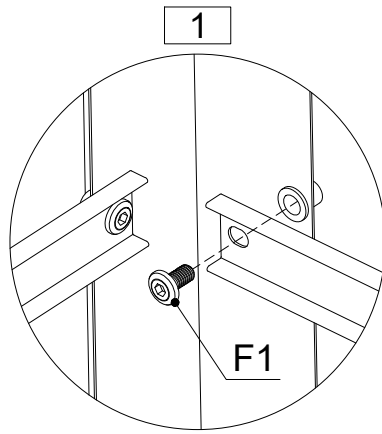

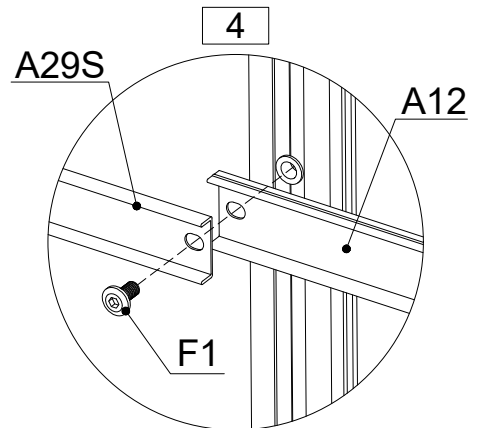
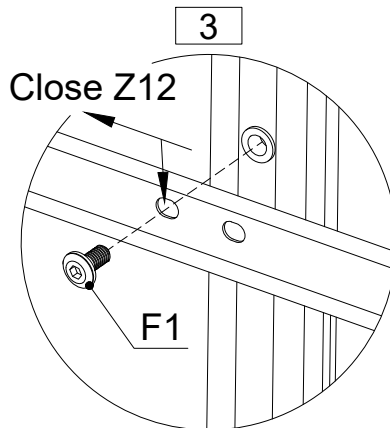
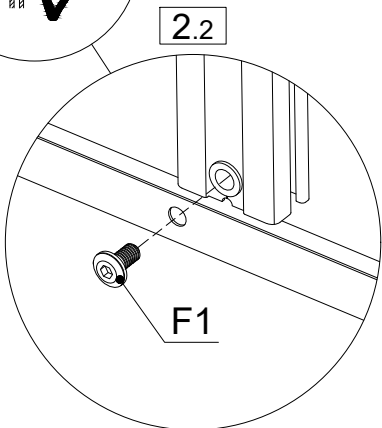
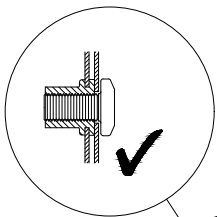
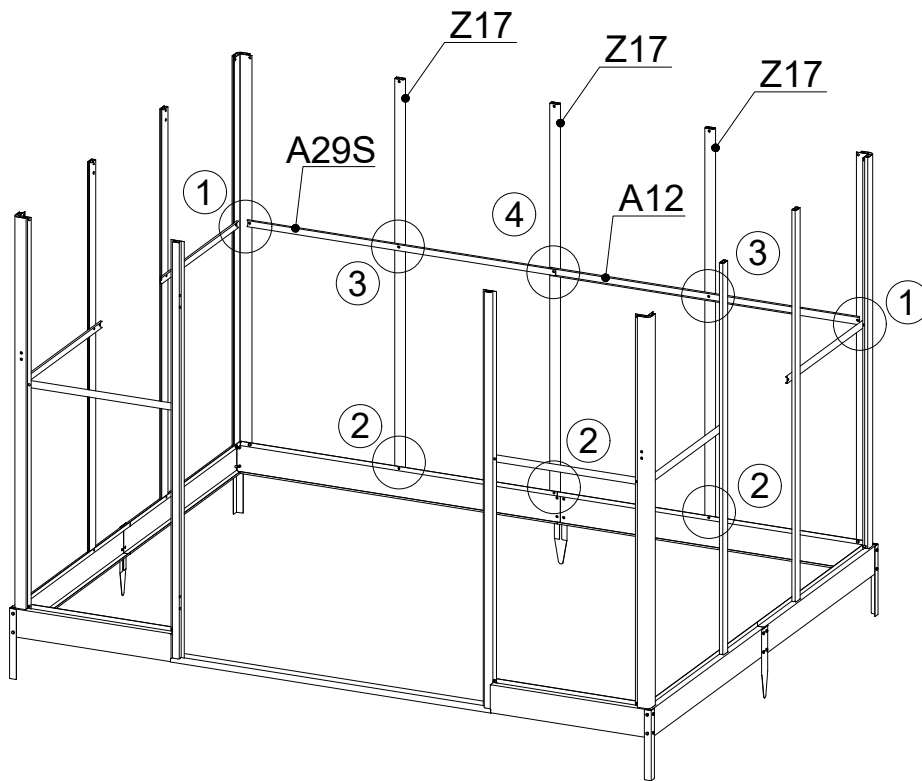

The little gap faces downwards.

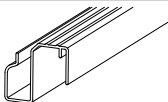
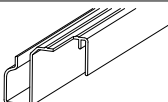

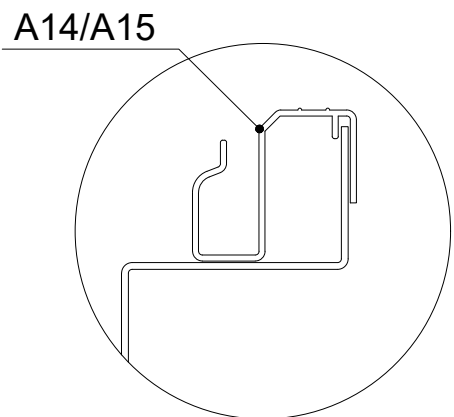
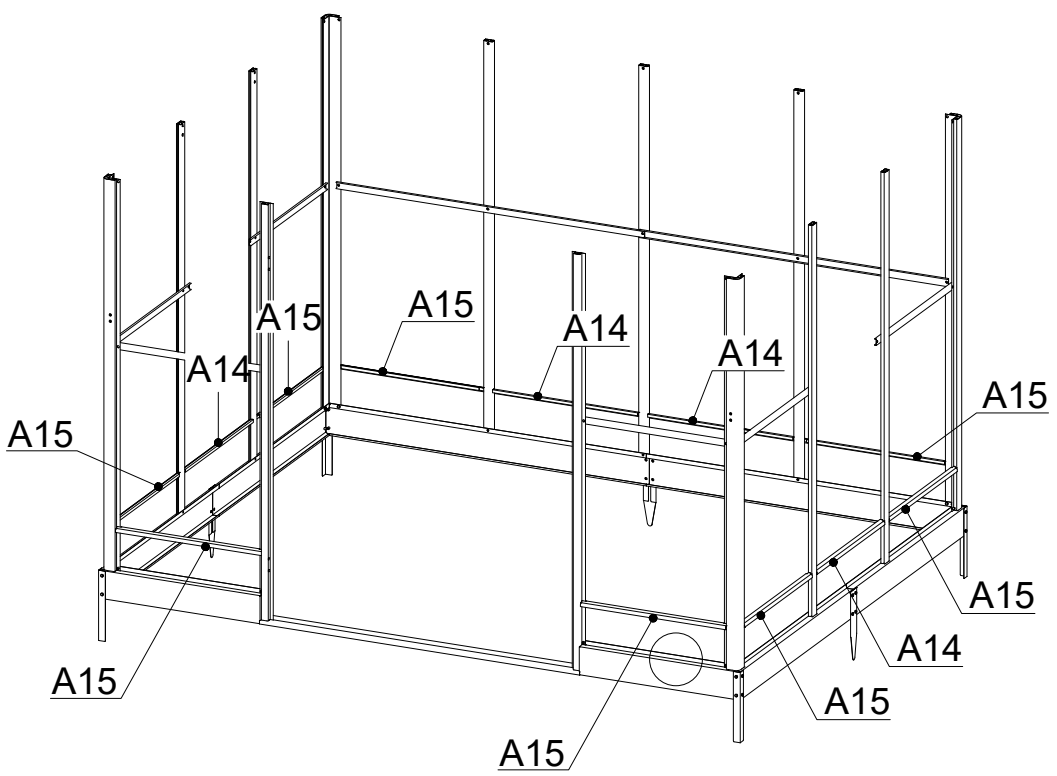
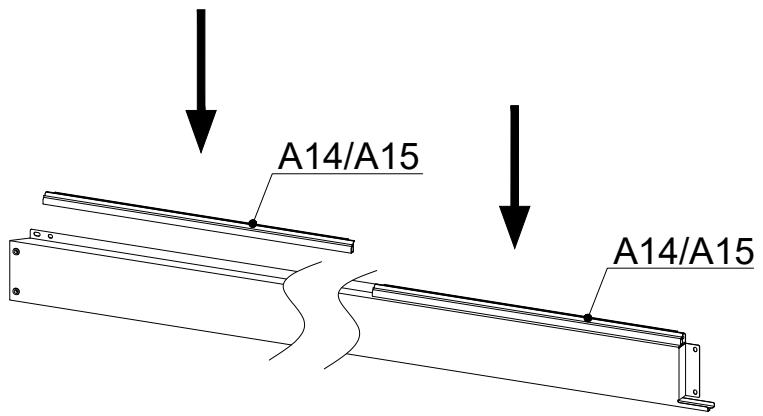
Part	Label	Qty
	A14	4
	A15	8



Part	Label	Qty
	N1	10
	N2	2

White Film  
(sunlight)

Transparent Film

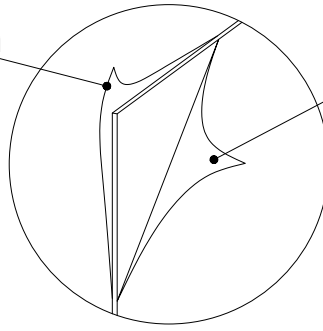

Remove the protective films  
before assemble boards

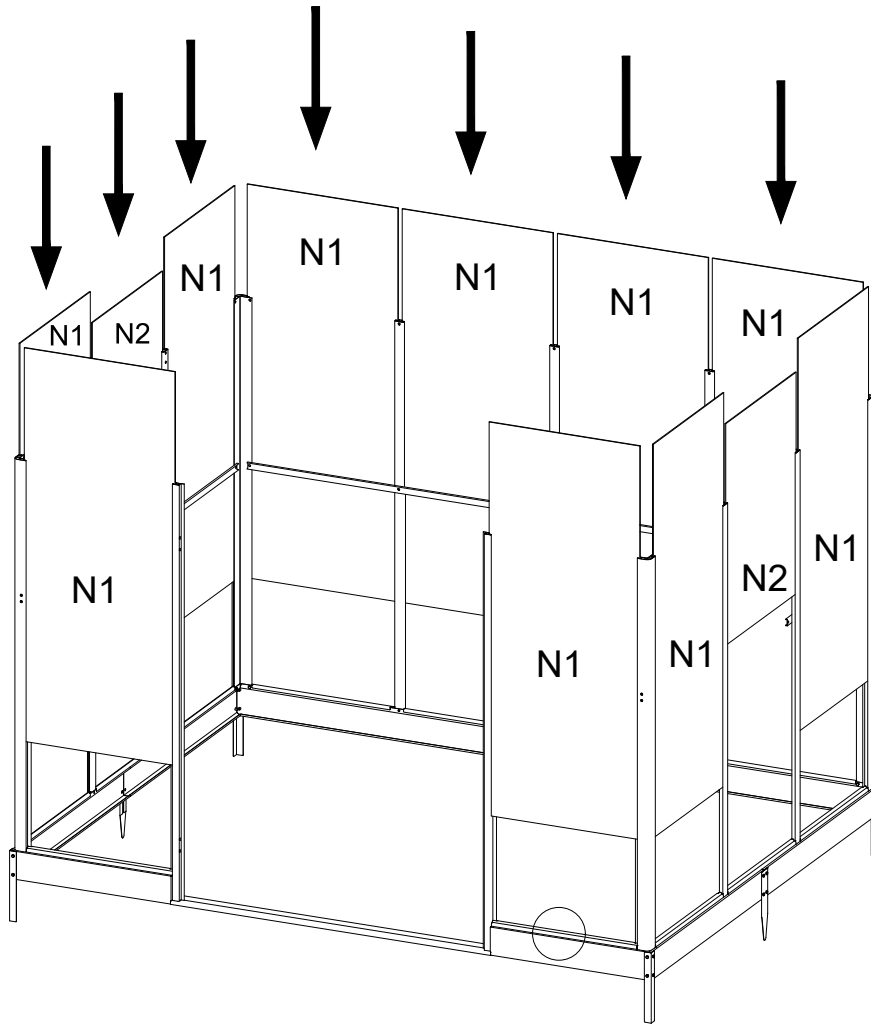

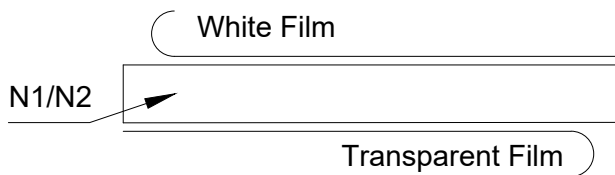
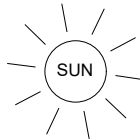

## Polycarbonate board

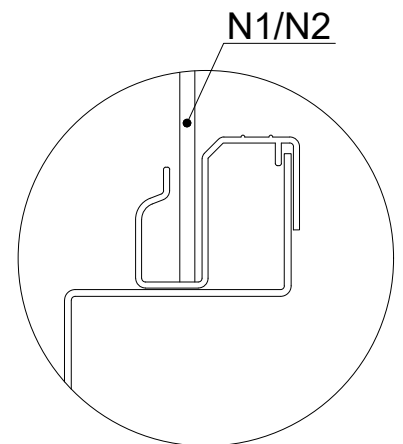

The UV-protected side of PC board is covered with white film which must face towards the Sun.

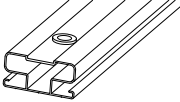



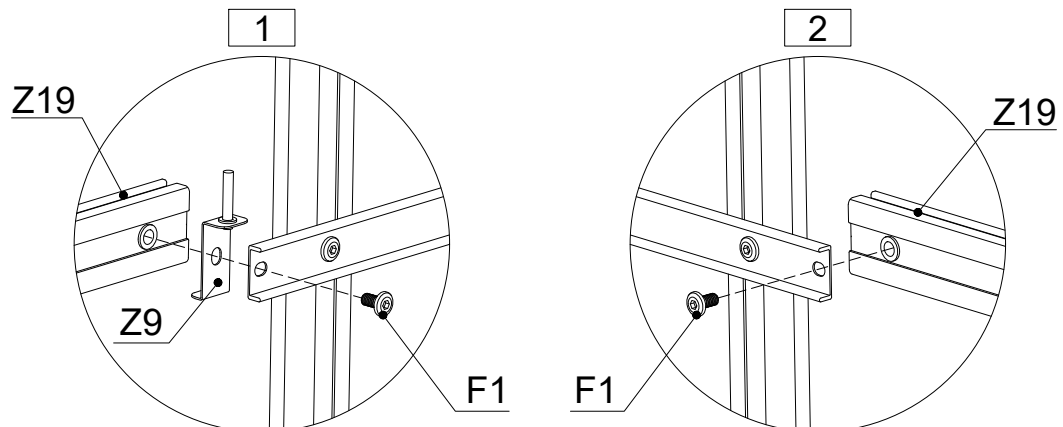
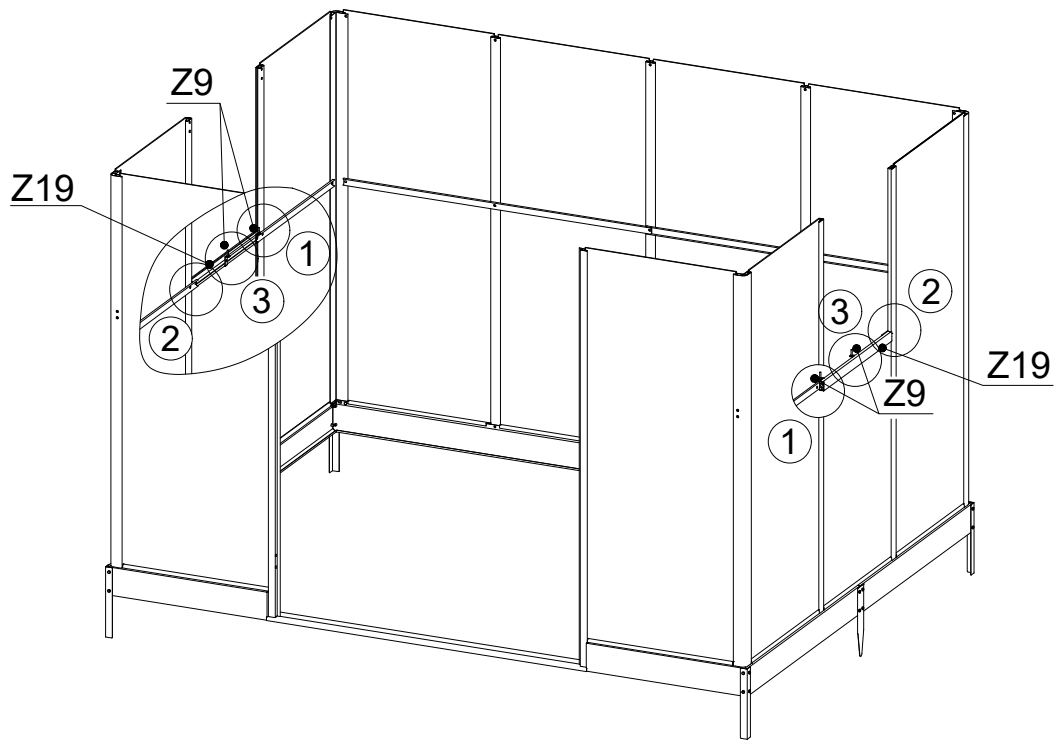
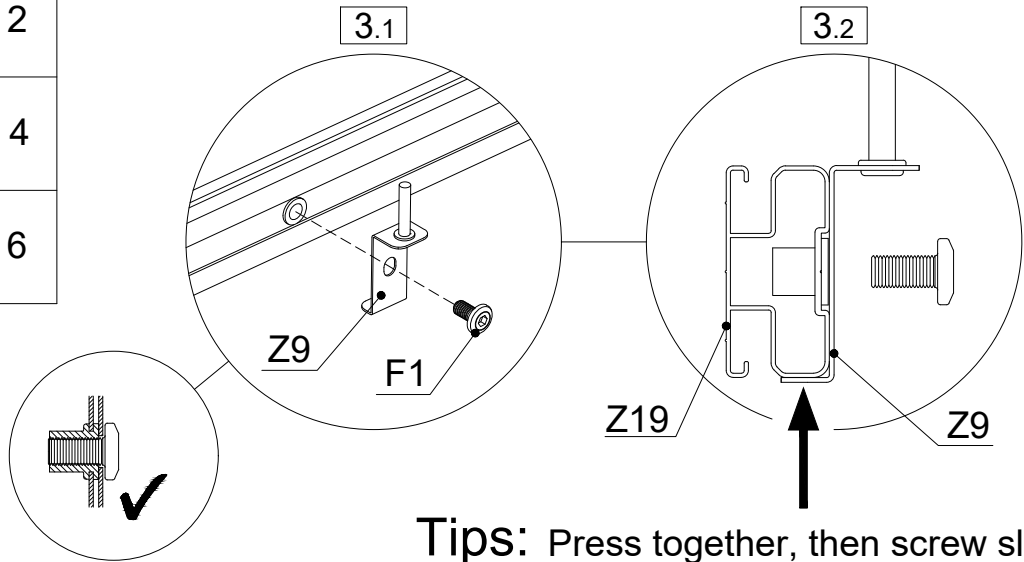

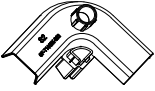
Part	Label	Qty
	Z19	2
	Z9	4
	F1	6
	M6X12	

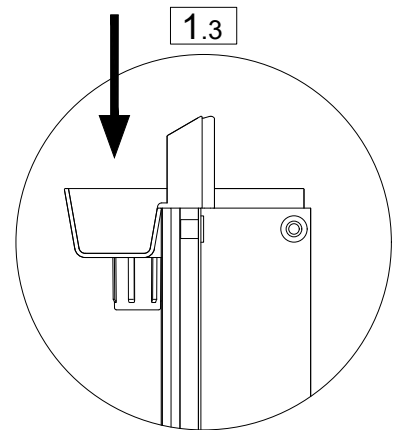
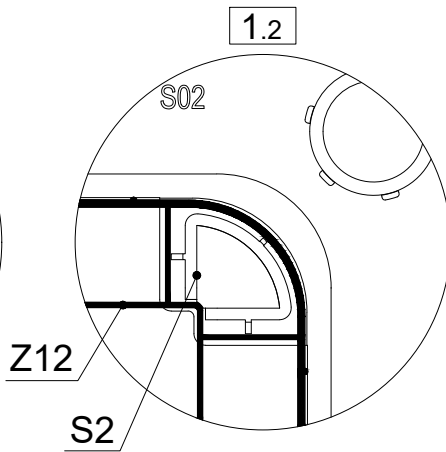
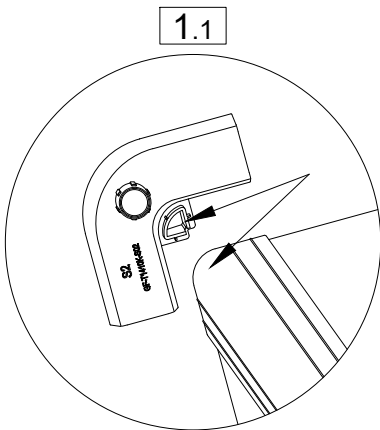
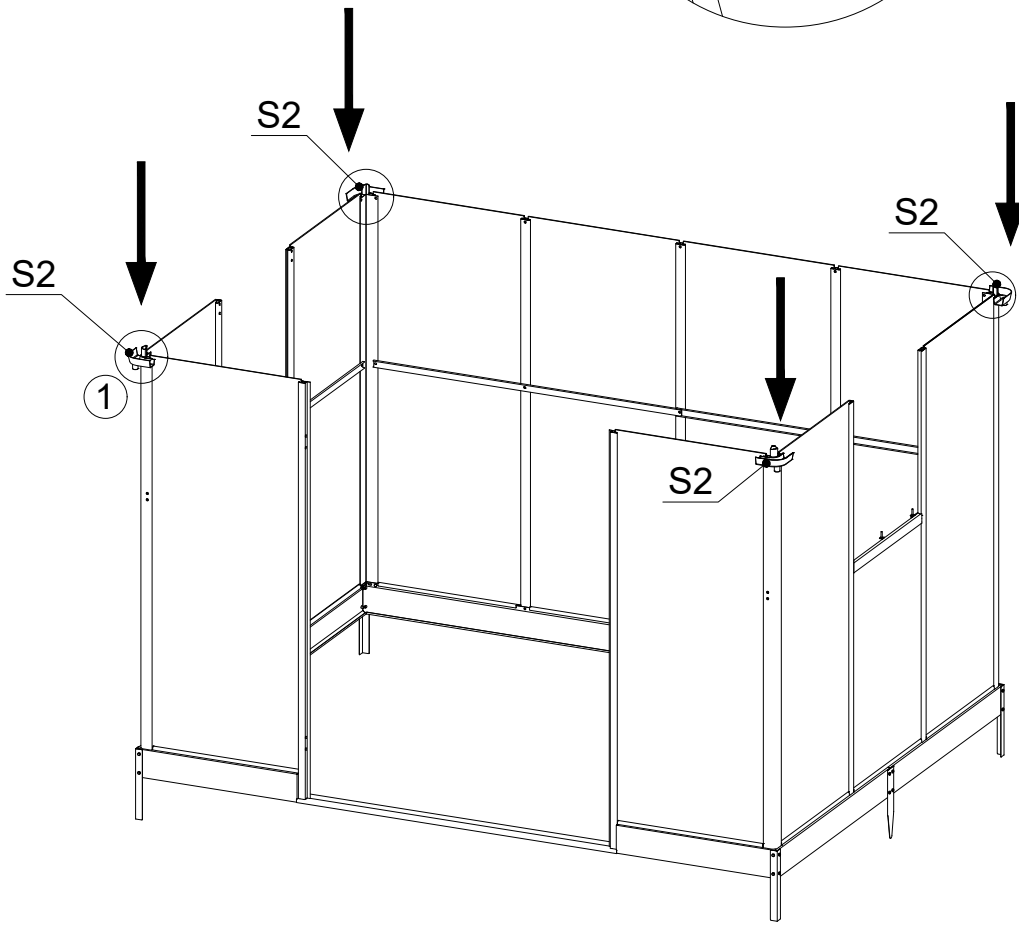
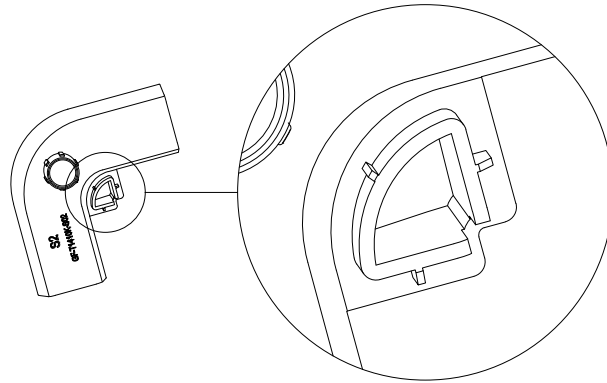

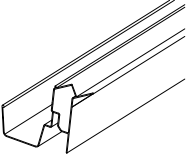

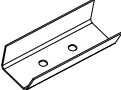
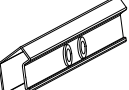
Part	Label	Qty
	S2	4



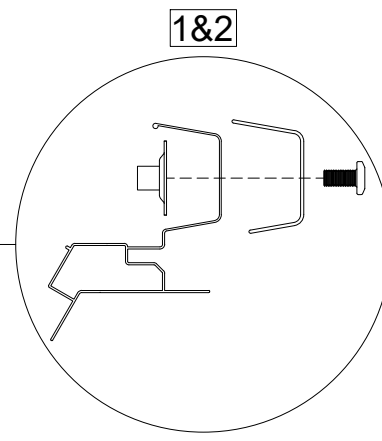
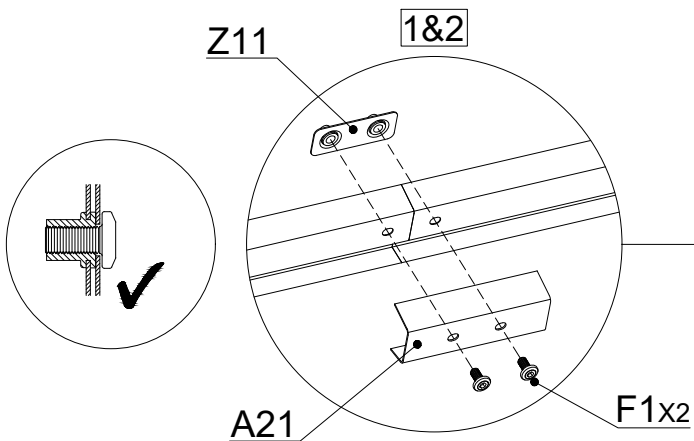
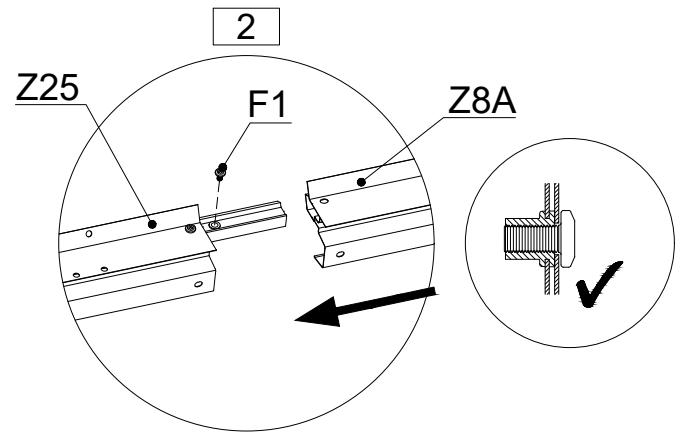
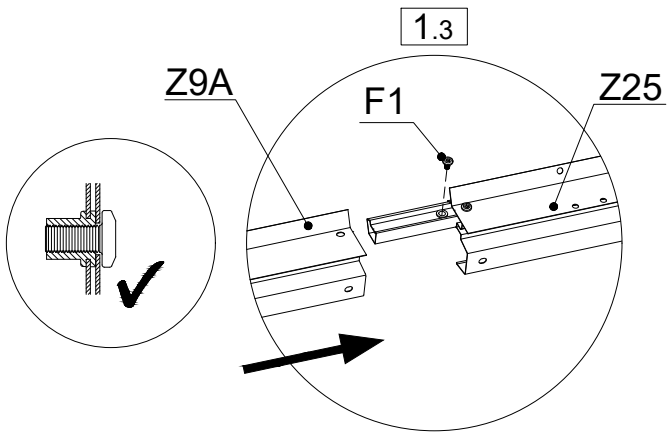
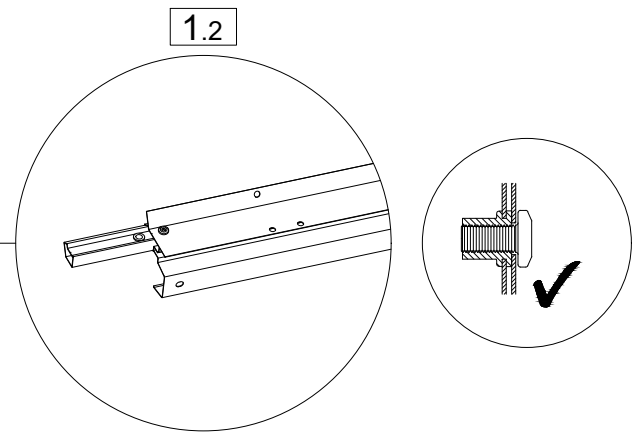
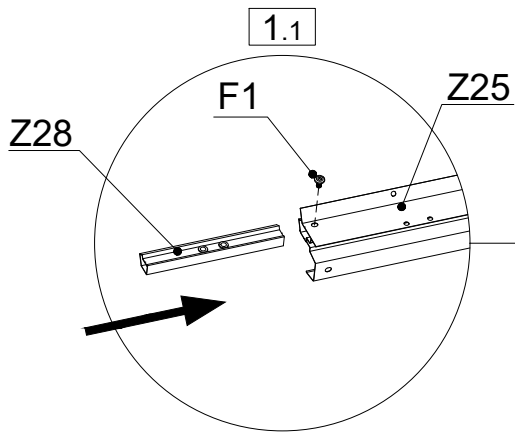
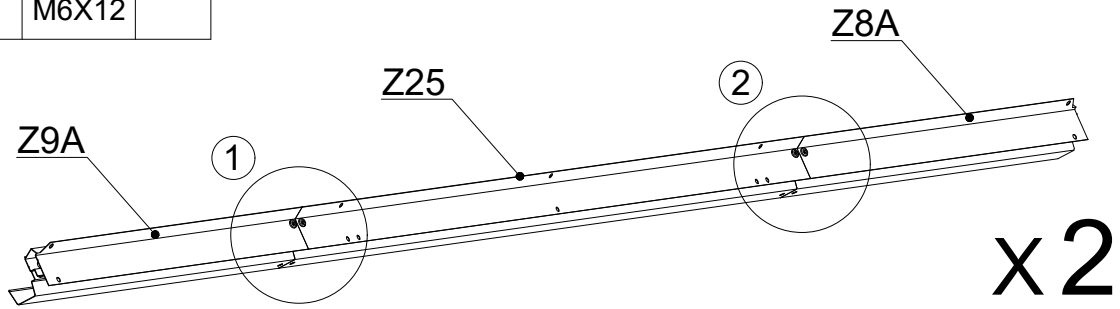

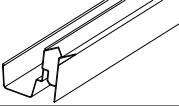
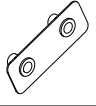
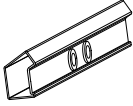
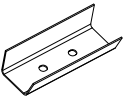
Part	Label	Qty	Part	Label	Qty
	Z8A	2		Z11	4
	Z9A	2			A21
	Z25	2			
	Z28	4			
	F1	16			
	M6X12				



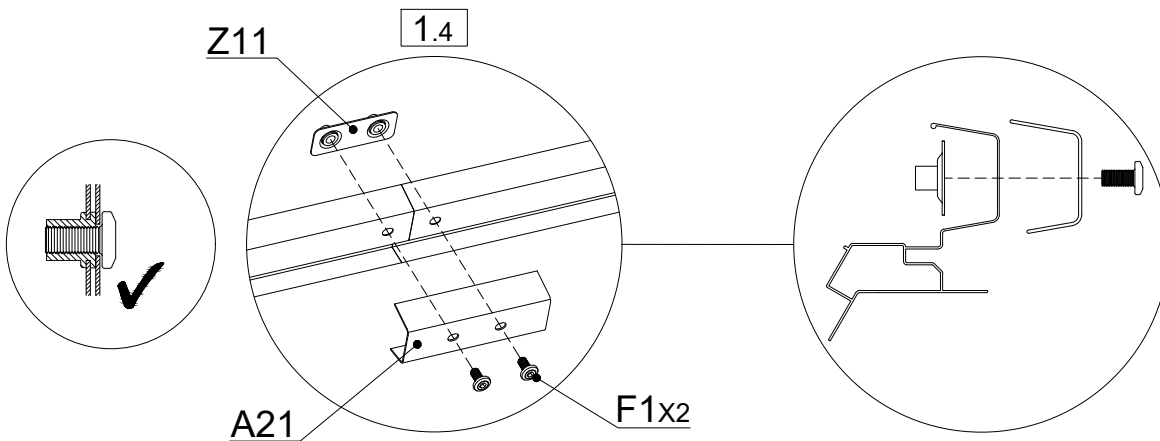
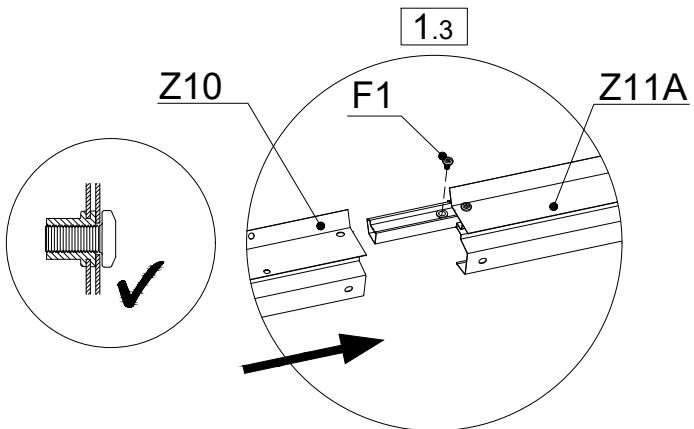
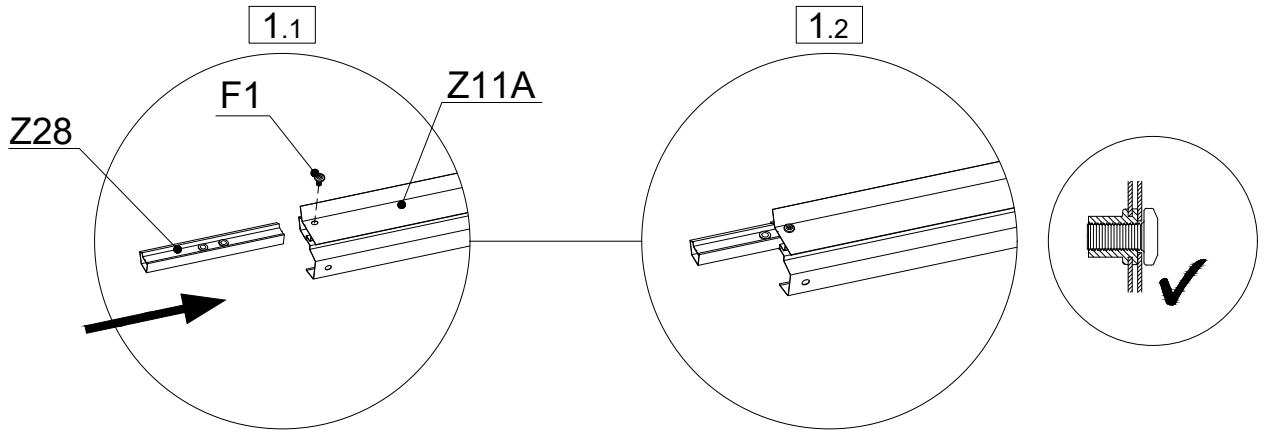
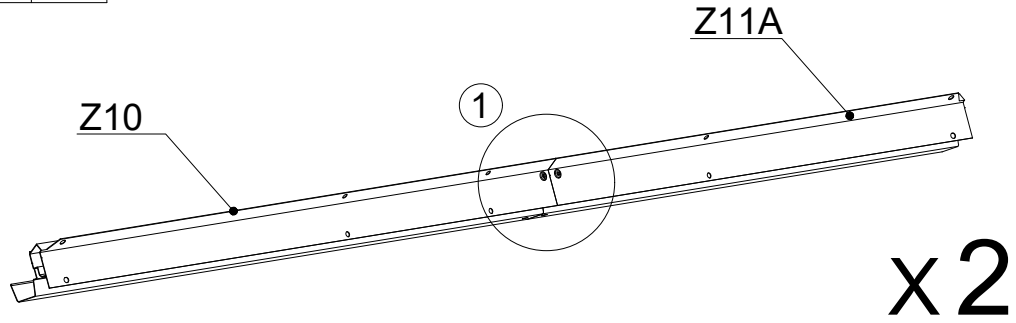

Part	Label	Qty	Part	Label	Qty
	Z10	2		Z11	2
	Z11A	2			
	Z28	2		A21	2
	F1	8			
	M6X12				



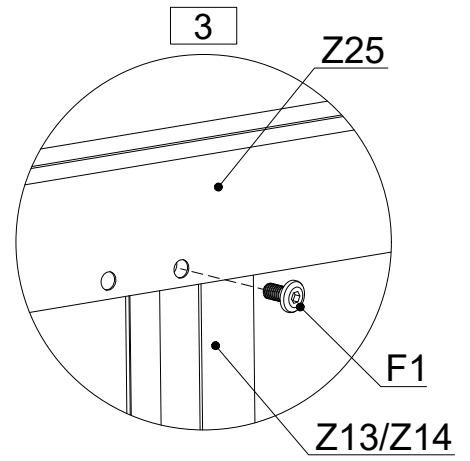
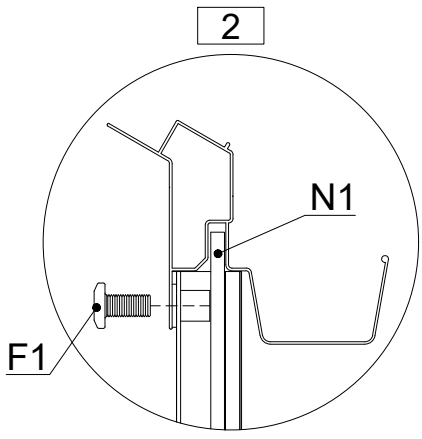
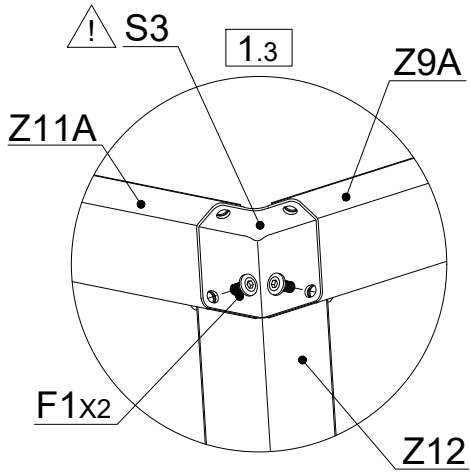
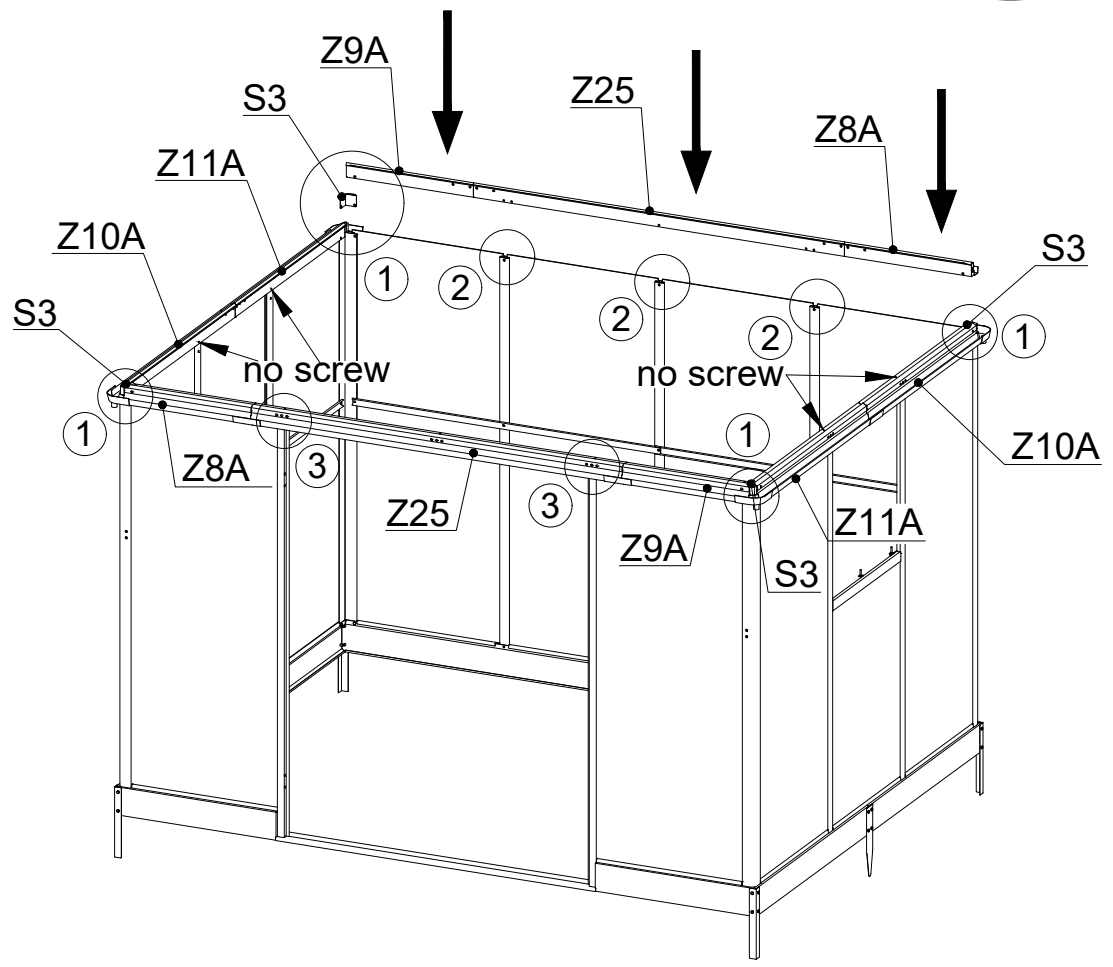
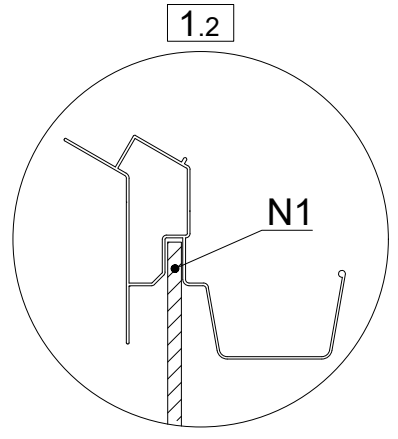
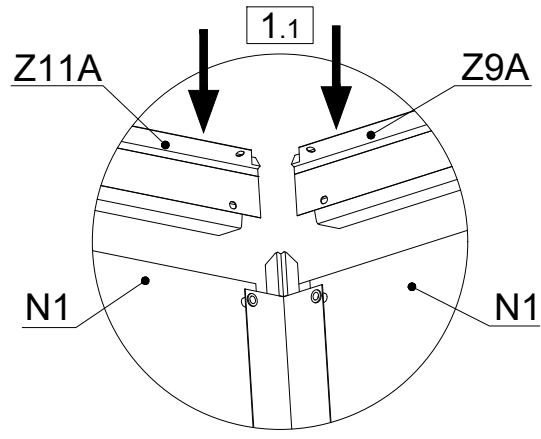

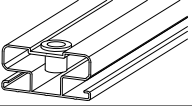
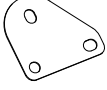
Part	Label	Qty
	S3	4
	F1 M6X12	13



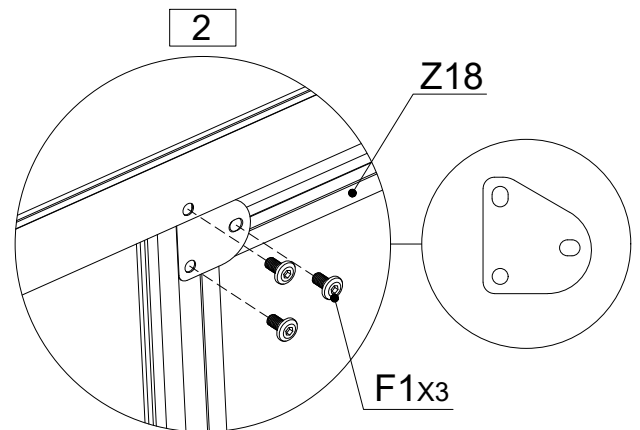
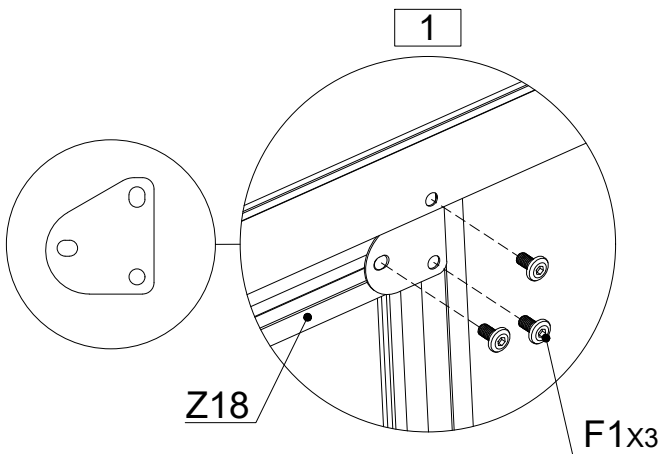
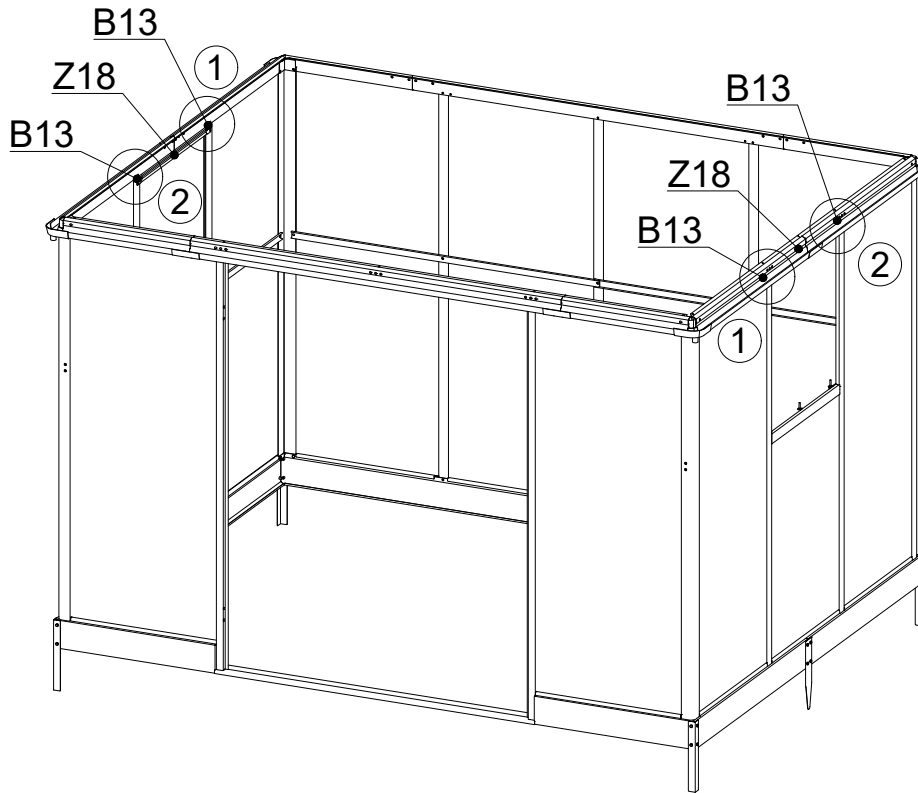
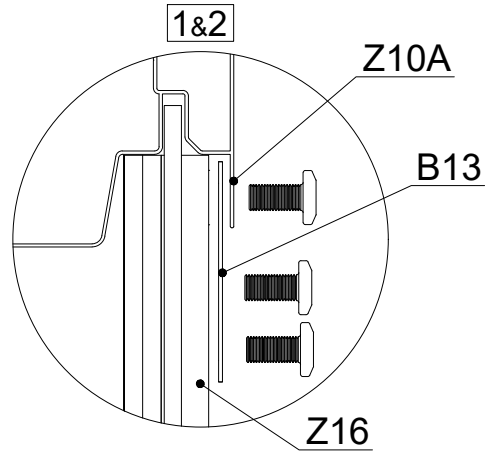

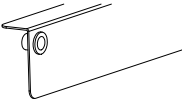
Part	Label	Qty
	Z18	2
	B13	4
	F1	12
	M6X12	



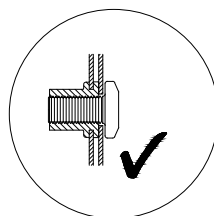
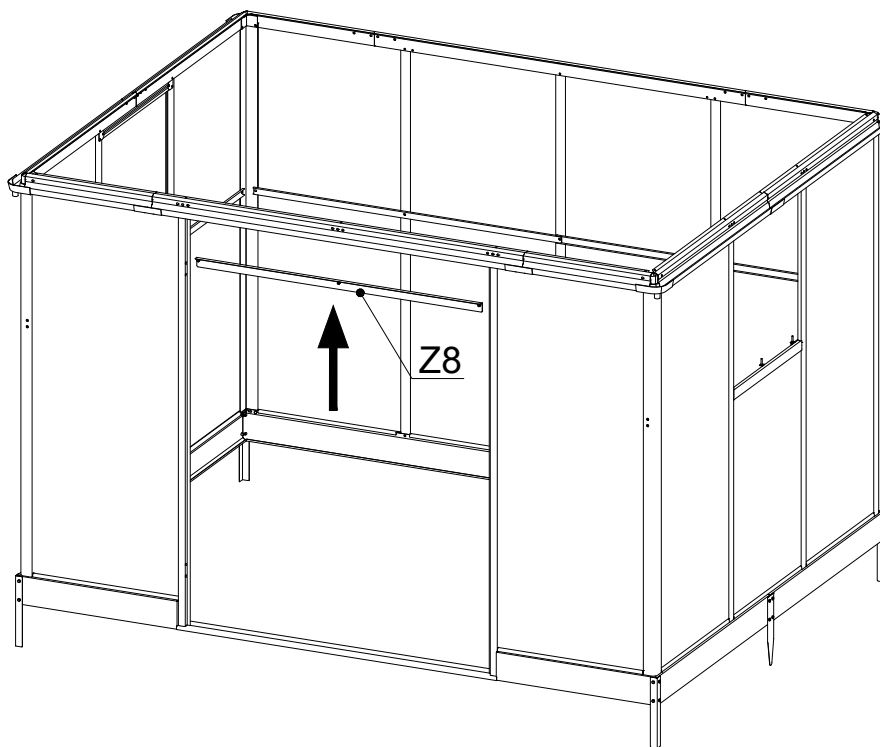
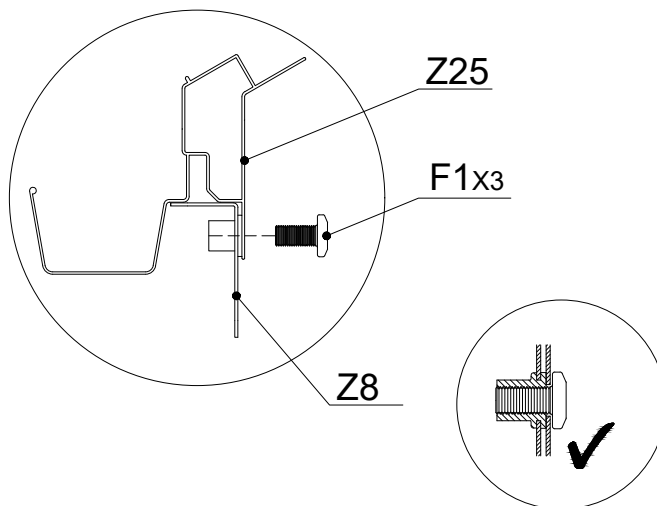

Part	Label	Qty
	Z8	1
	F1	3
	M6X12	

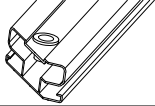
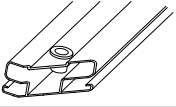

Please tighten all bolts which already installed.

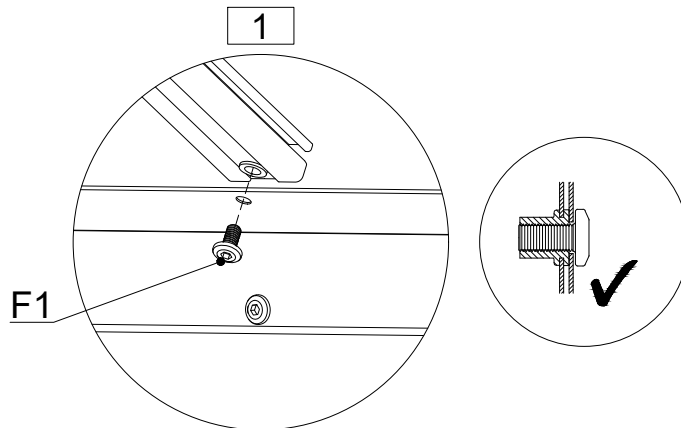
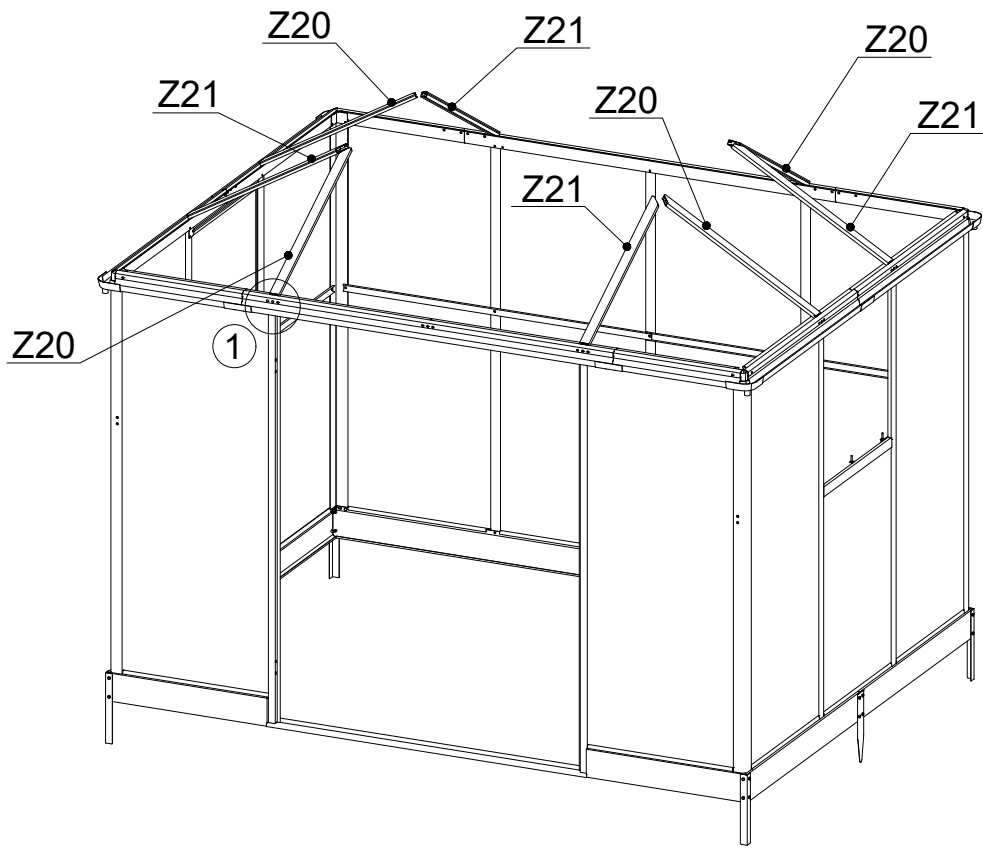
Part	Label	Qty
	Z20	4
	Z21	4
	F1	8
	M6X12	

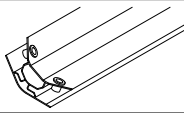

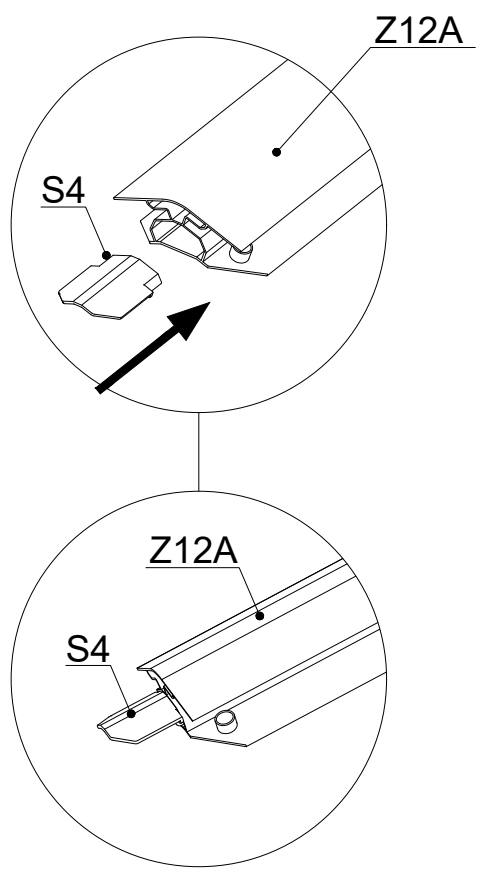
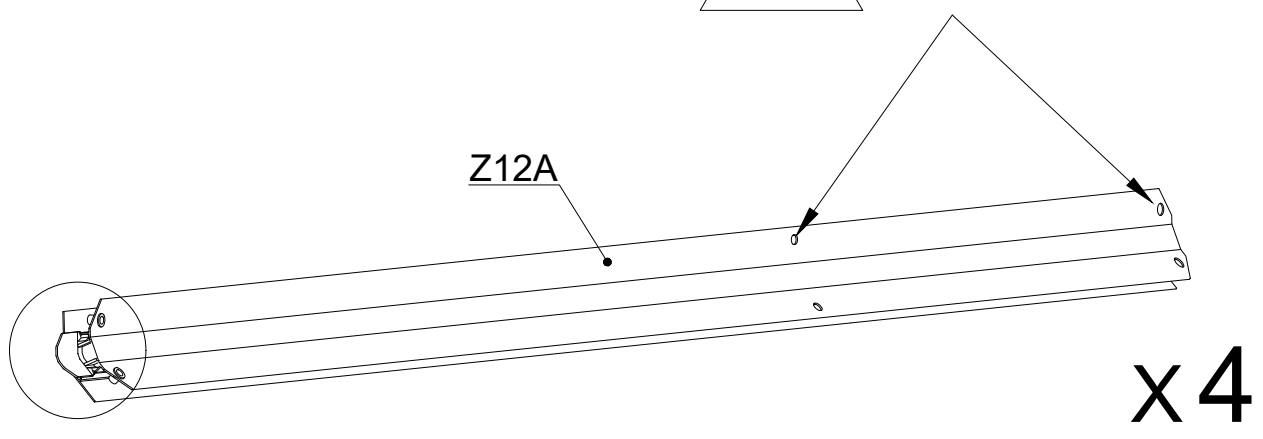

Part	Label	Qty
	Z12A	4
	S4	4

 Holes closer.



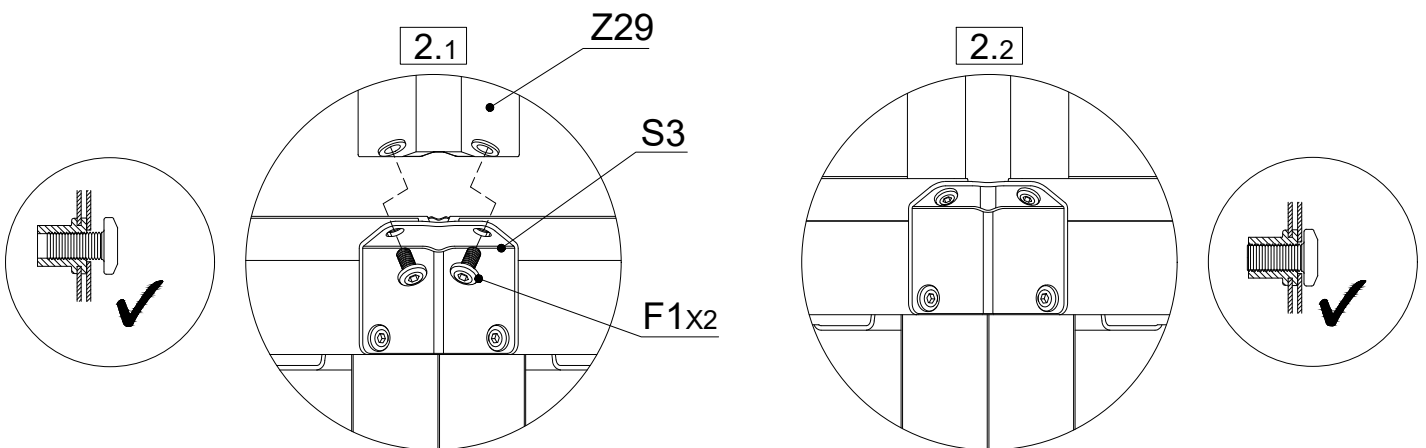
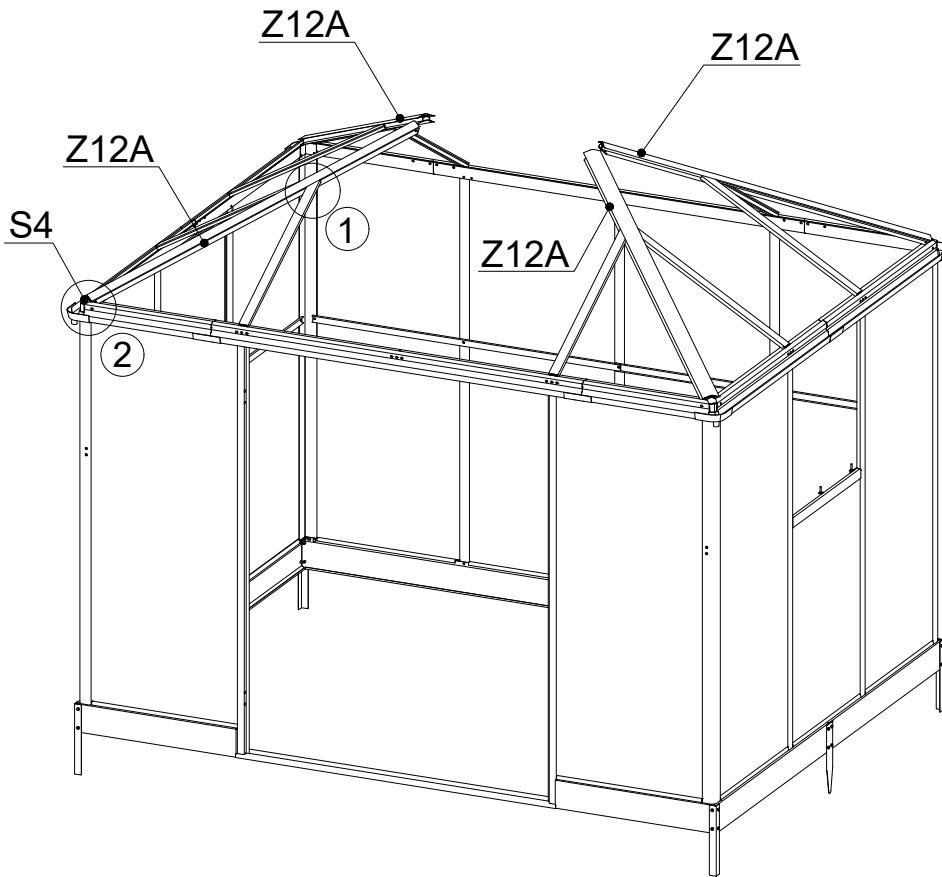
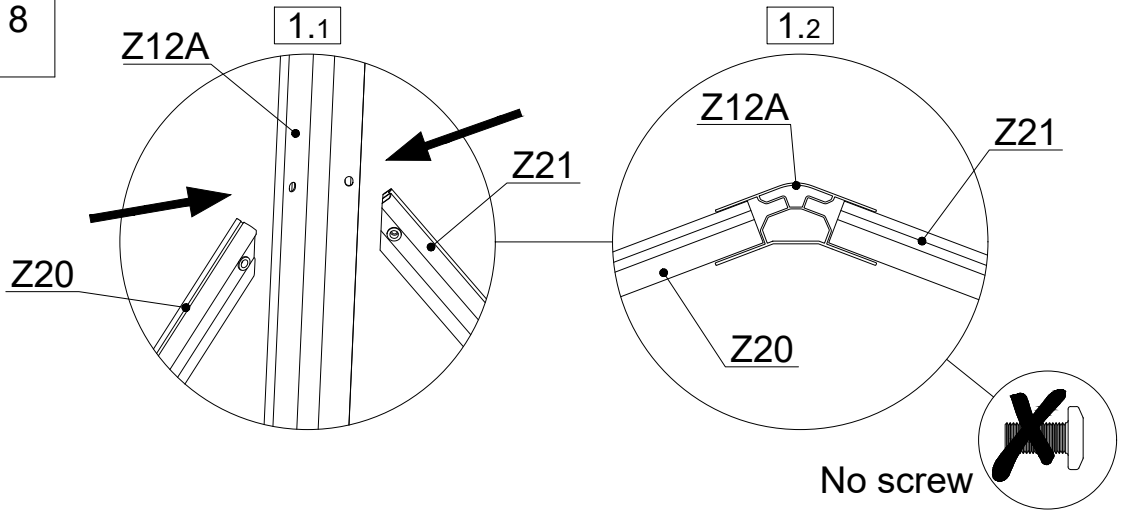

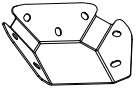

Part	Label	Qty
	F1	8
	M6X12	

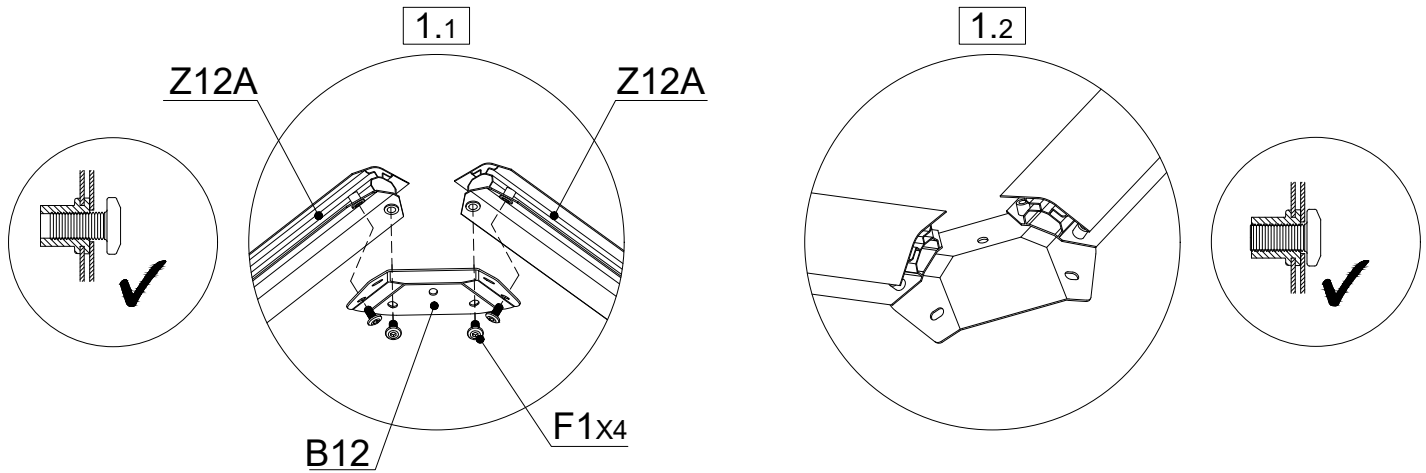
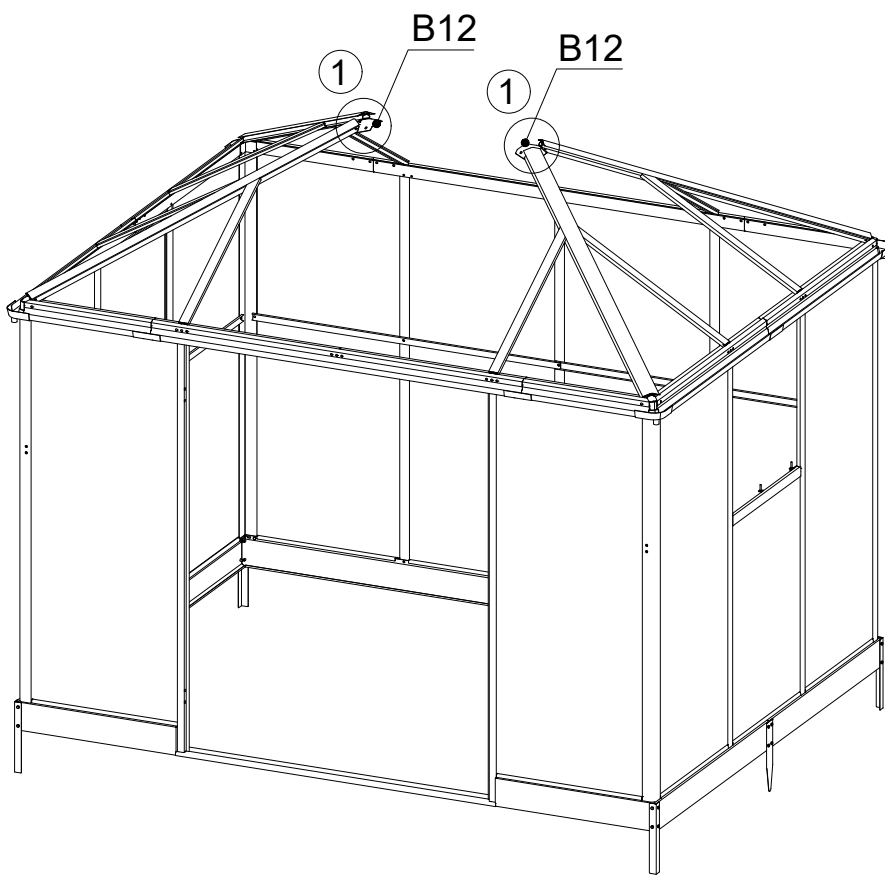

Part	Label	Qty
	B12	2
	F1	8
	M6X12	

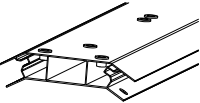

Part	Label	Qty
	S6	3
	S7	2
	Z13A	1
	F1	10
	M6X12	

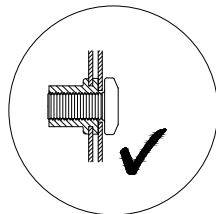
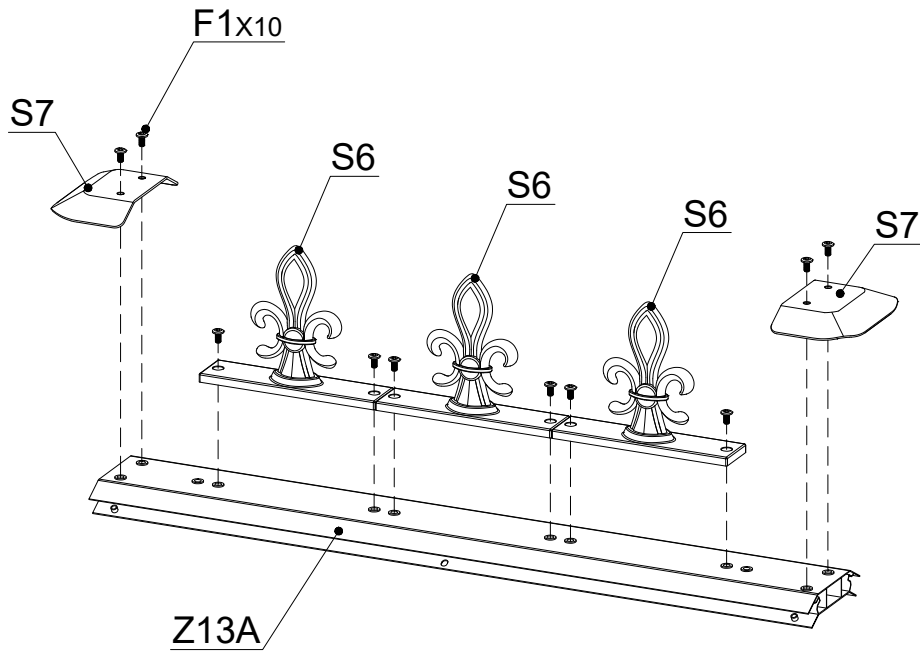

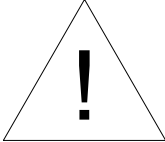
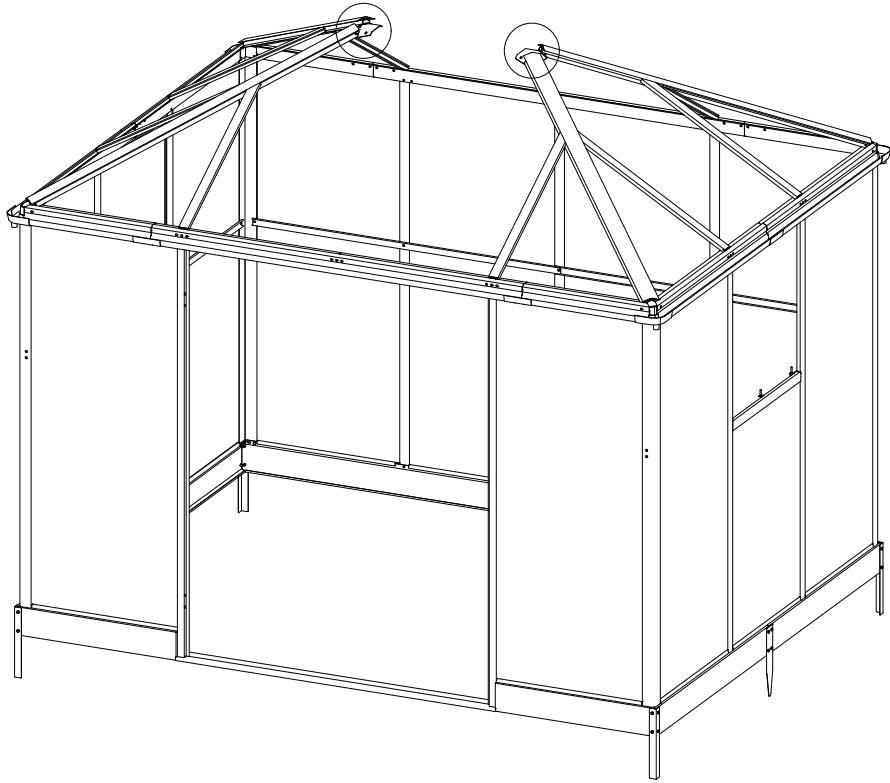
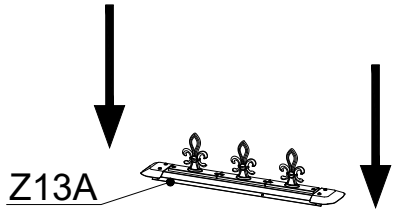
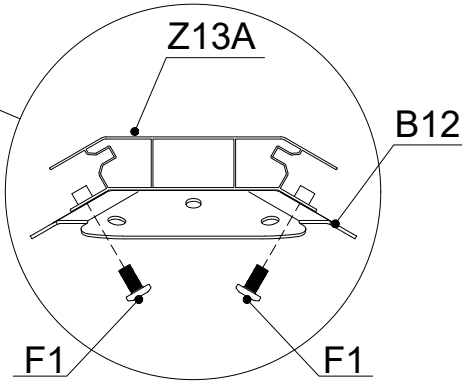
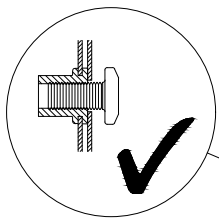

Part	Label	Qty
	F1	4
	M6X12	

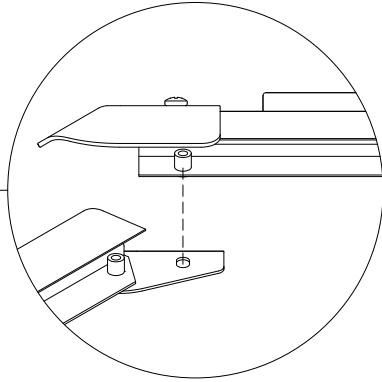
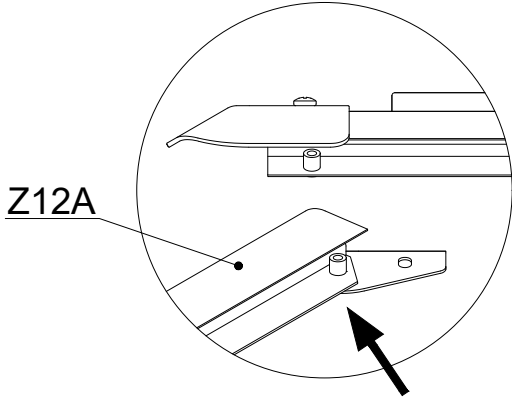

Attention: Z12A hangs down.



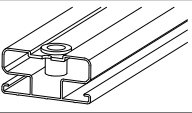

Push upwards

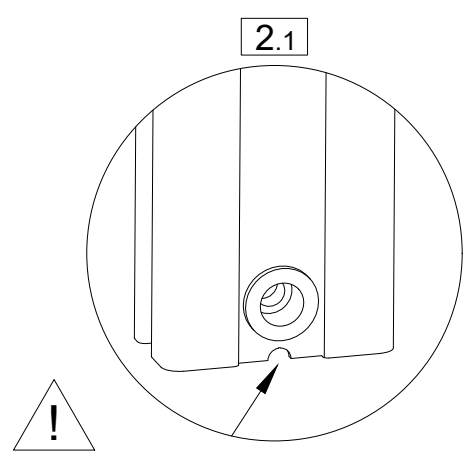
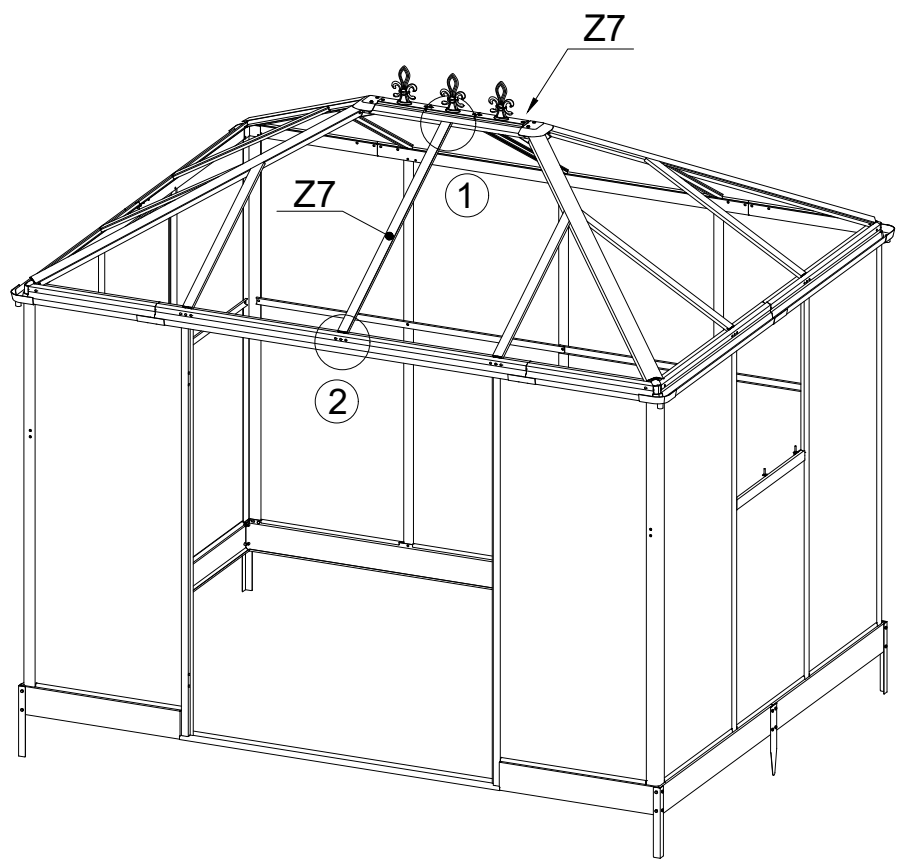
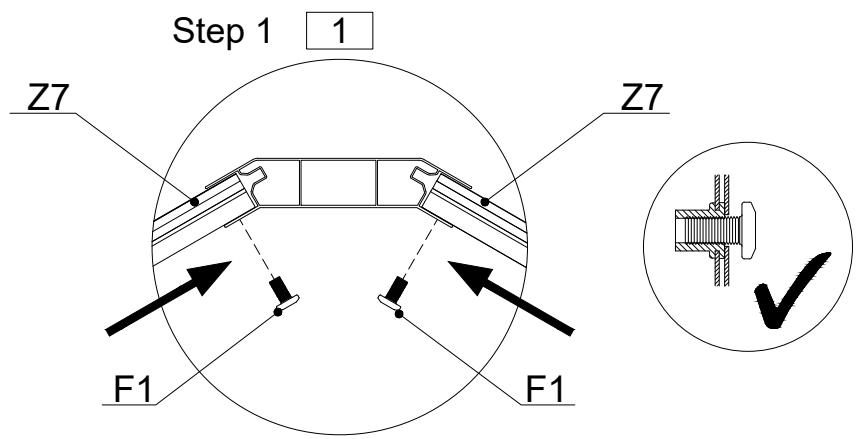
Part	Label	Qty
	Z7	2
	F1 M6X12	4



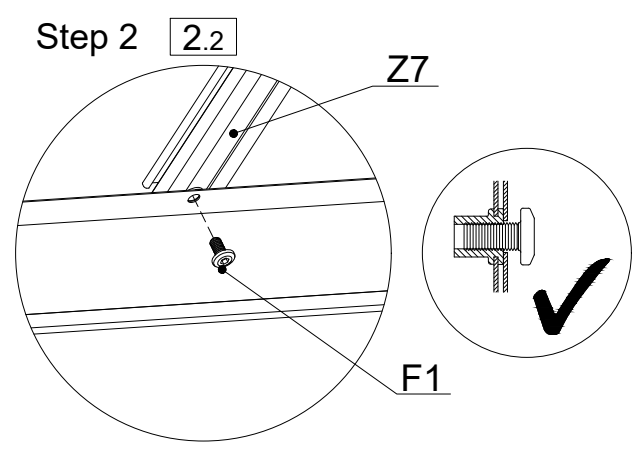



The little gap faces downwards.

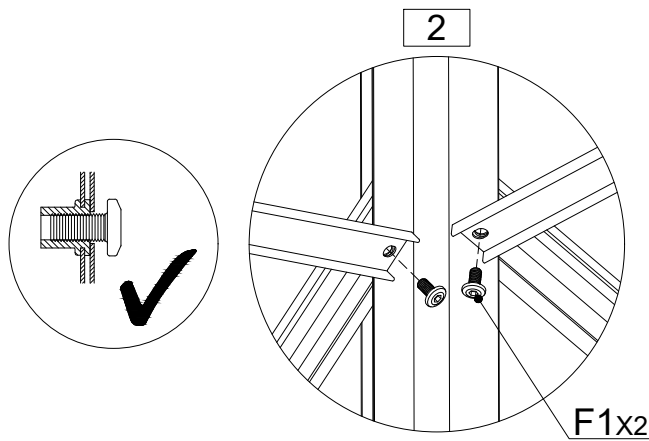
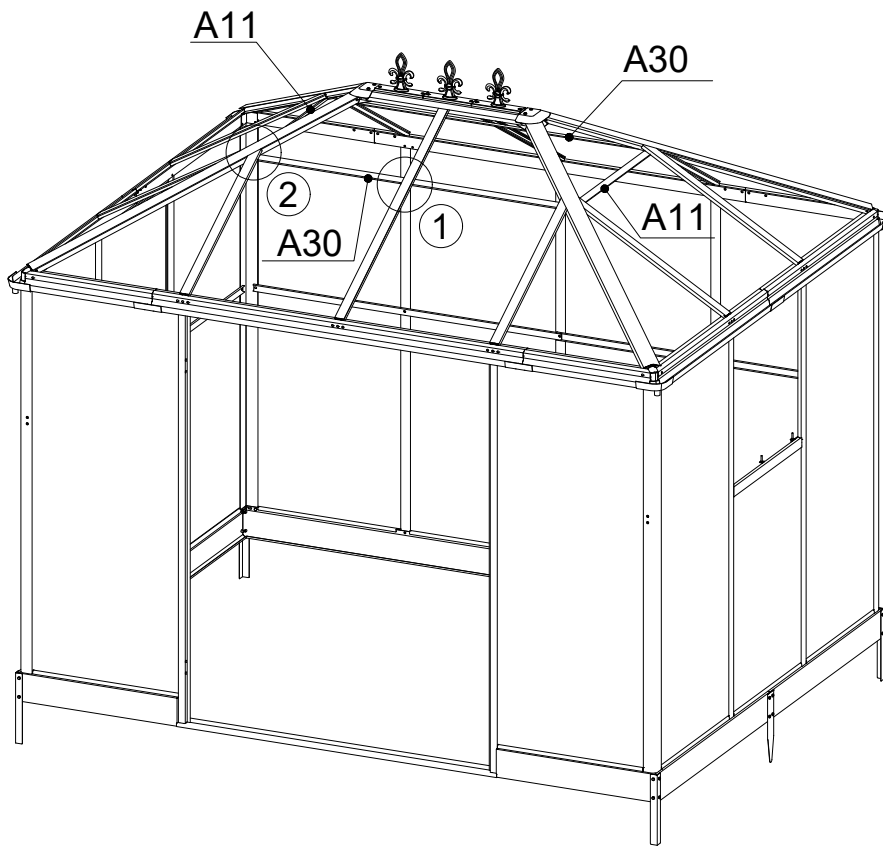
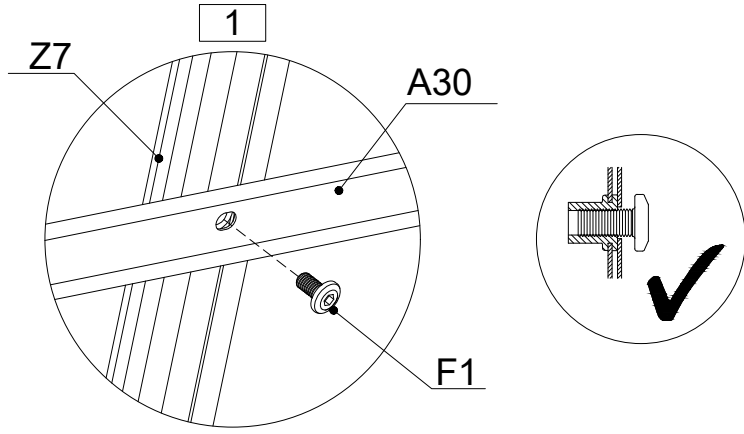

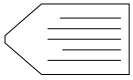
Part	Label	Qty
	A11	2
	A30	2
	F1	10
	M6X12	

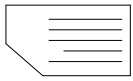

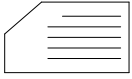
Part	Label	Qty	Part	Label	Qty
	P1	2		P4	4
	P2	2		P5	4
	P3	2			

White Film  
(sunlight)

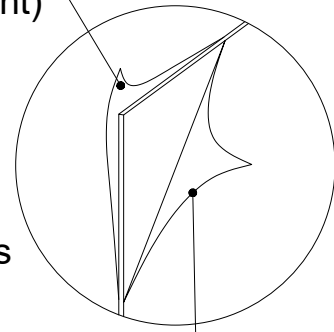

Transparent Film

Remove the protective films  
before assemble boards

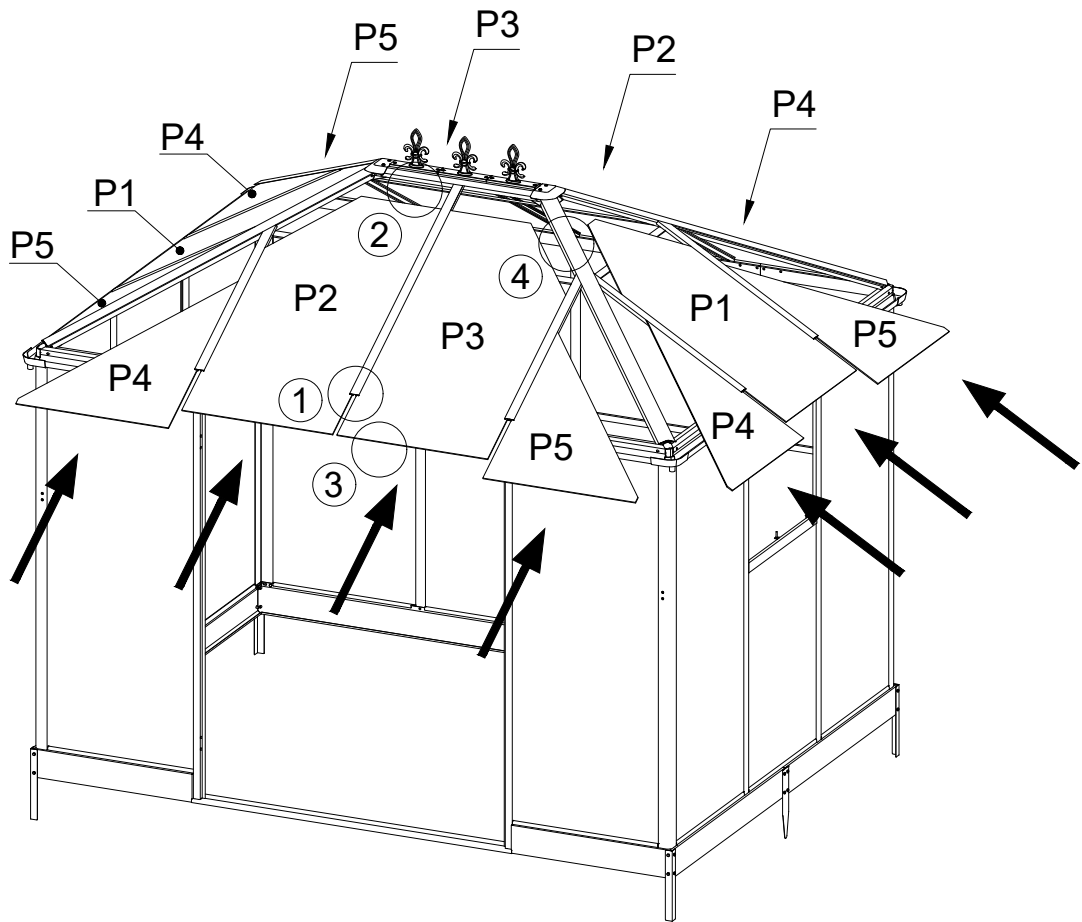

## Polycarbonate board

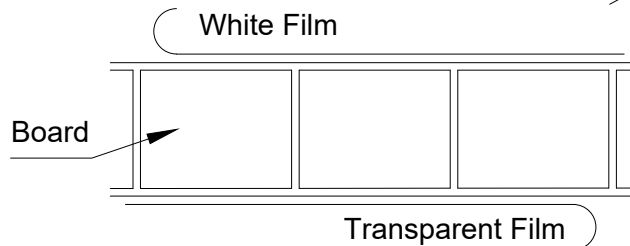
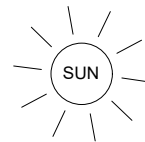

The UV-protected side of PC board is covered with white film which must face towards the Sun.





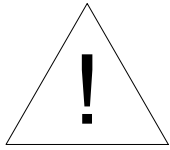

Please refer to the next page for detail description

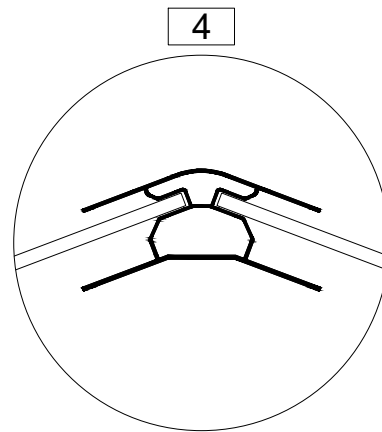
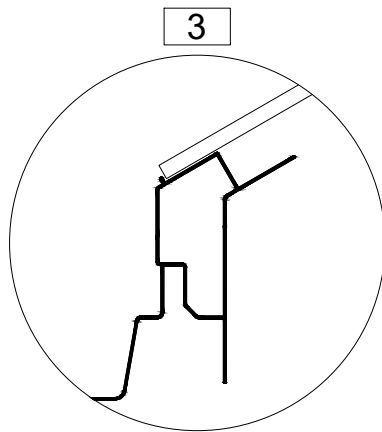
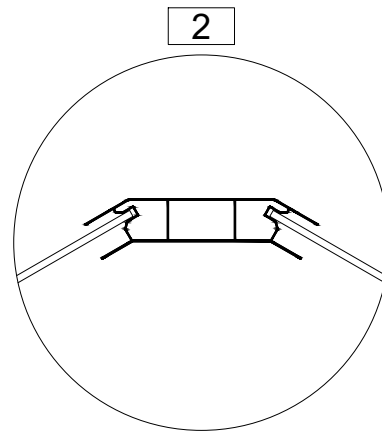
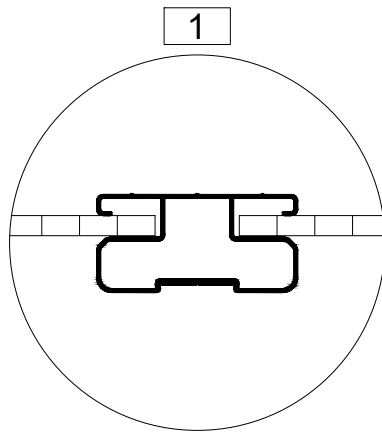

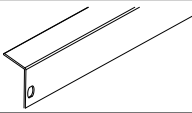
Attention: If can't insert boards into aluminum groove smoothly, need push a bit from inside.

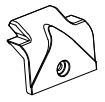

Part	Label	Qty
	A13	2
	A31	6
	S8	4
	S9	10
	F1	26
	M6X12	

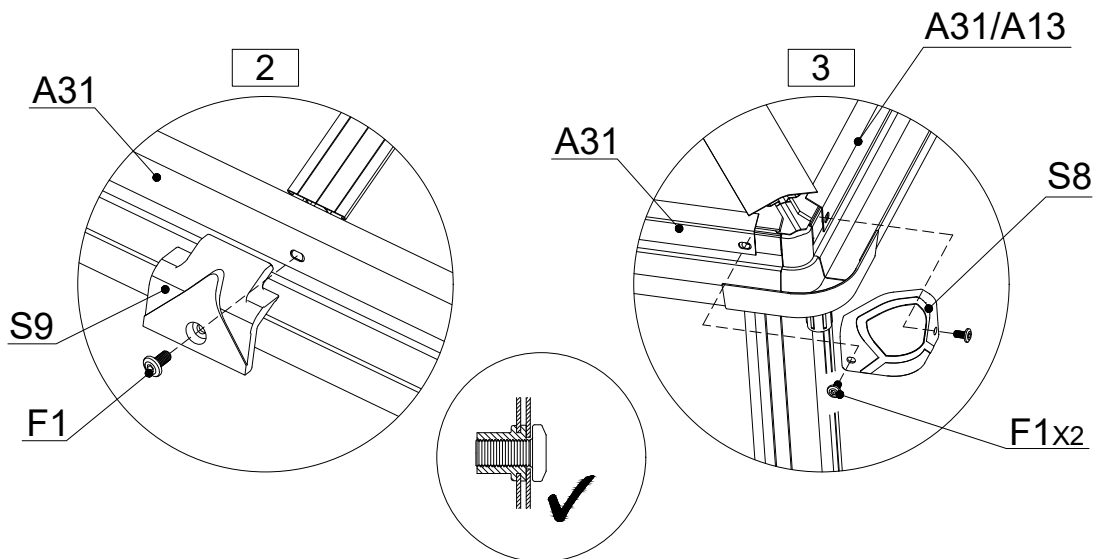
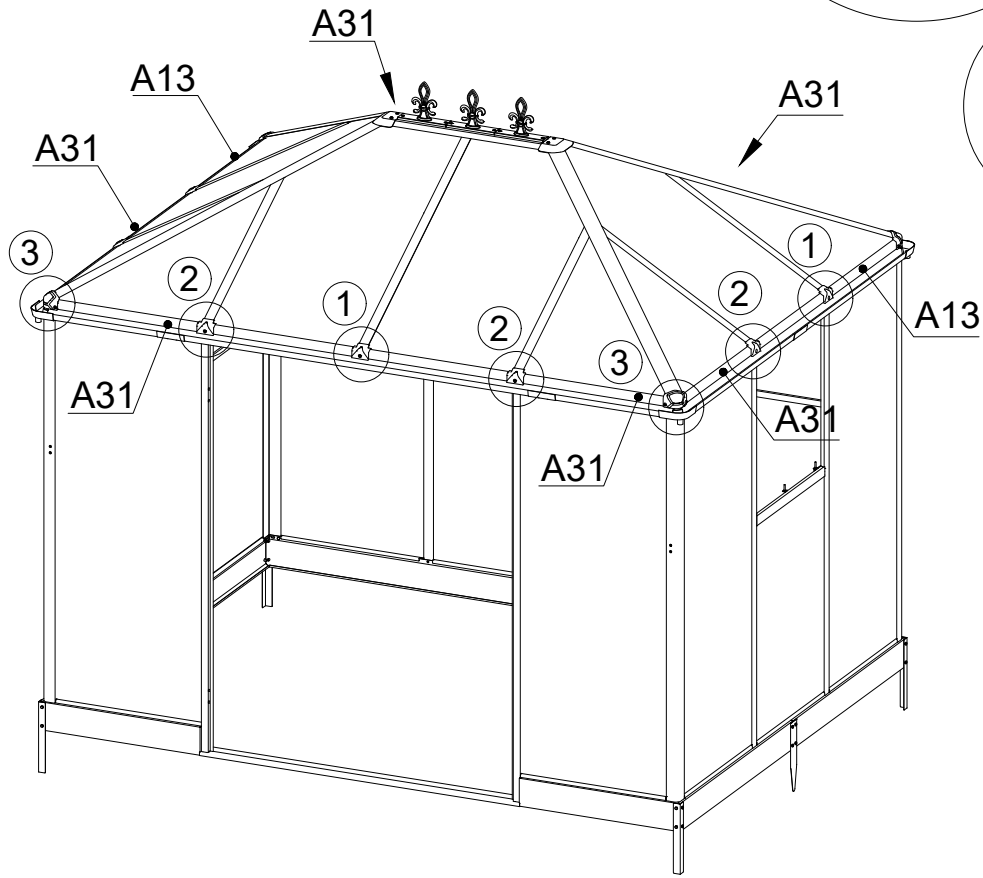
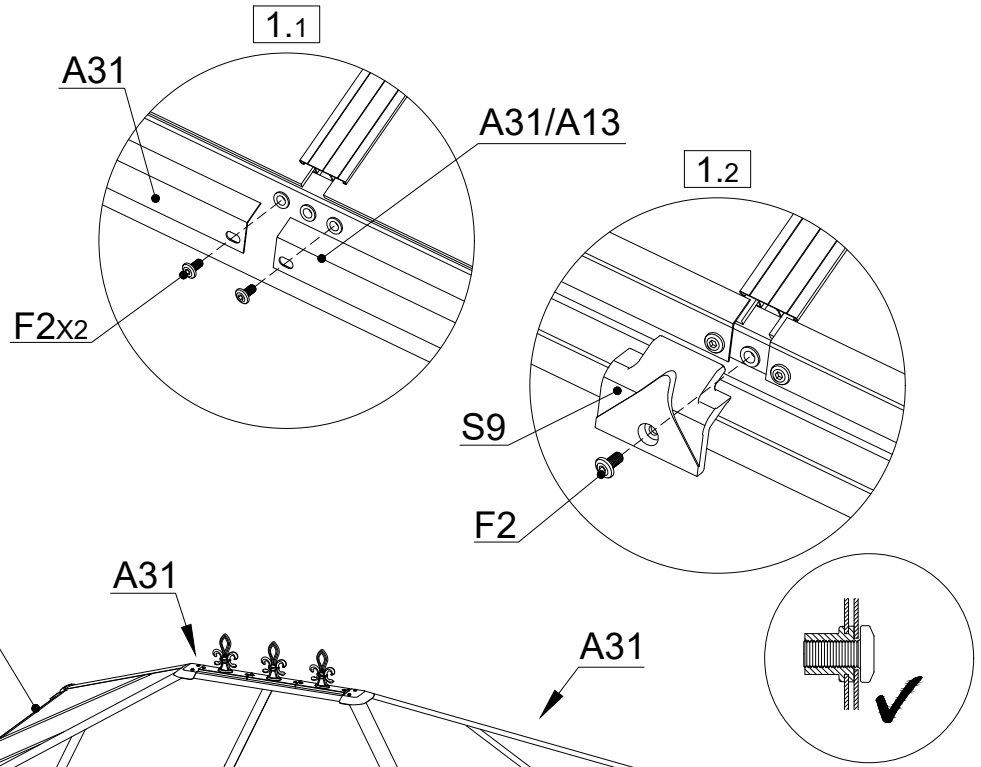

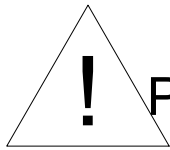
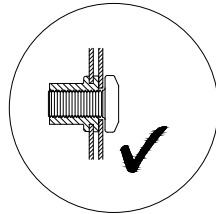

Please tighten all bolts which already installed.

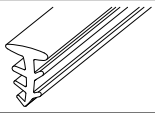
Part	Label	Qty
	T3	2

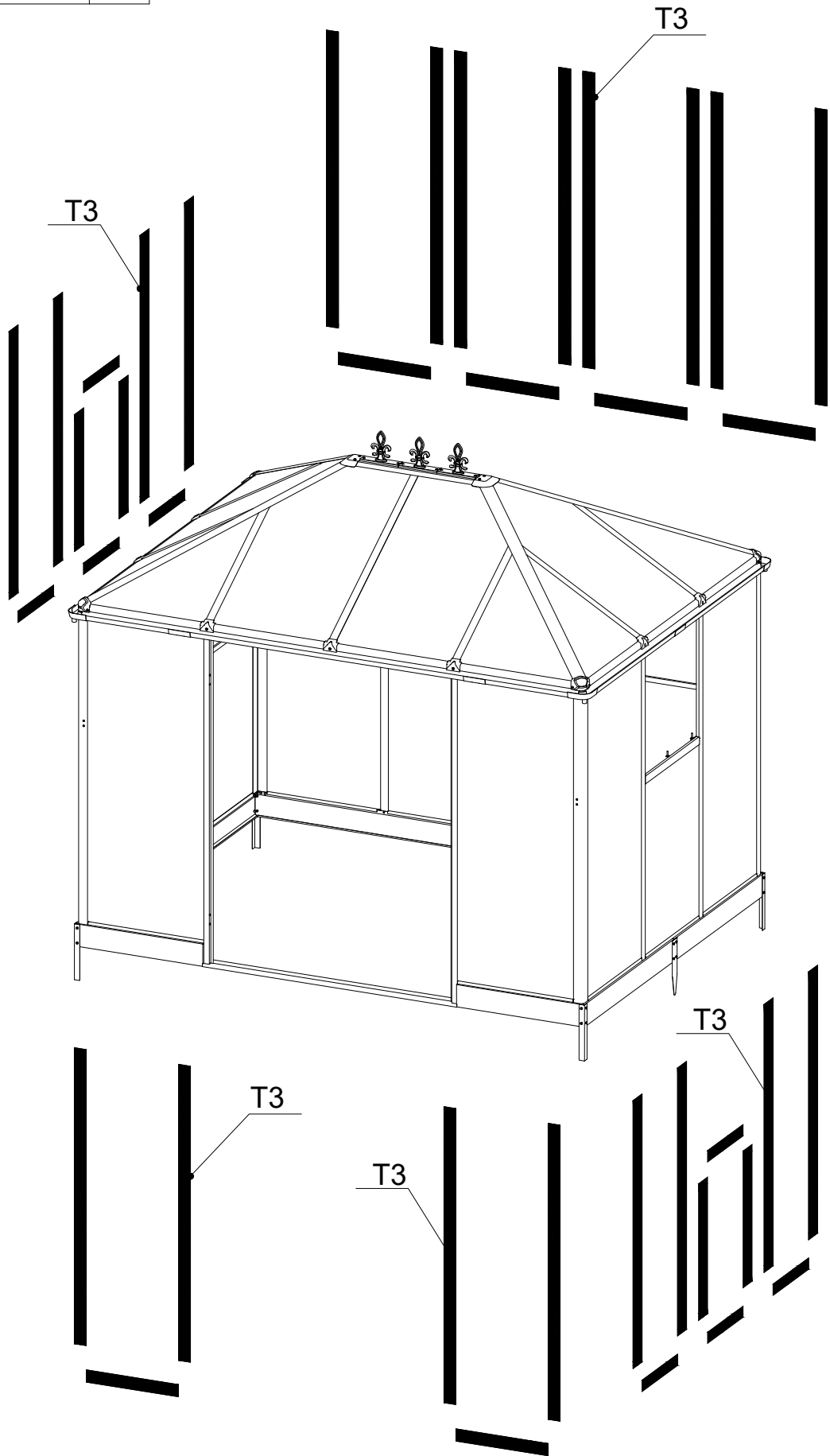

Please refer to the next page for detail description

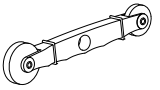

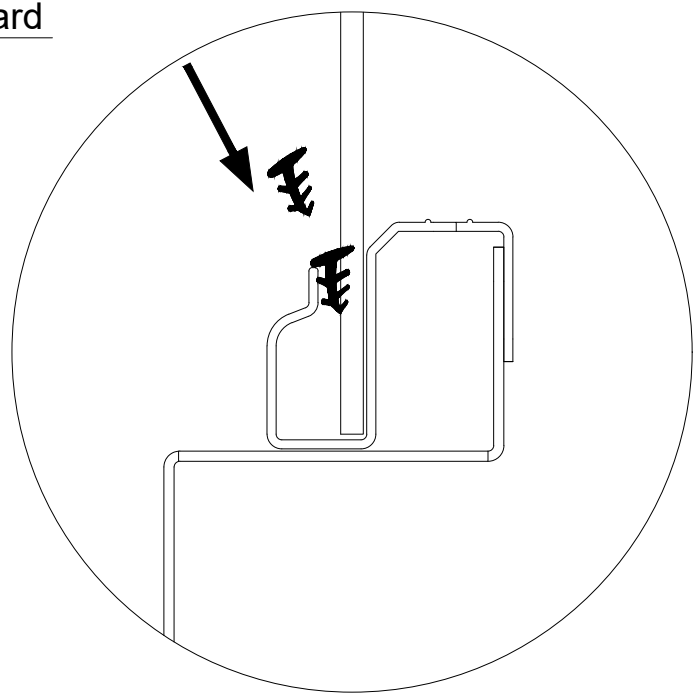
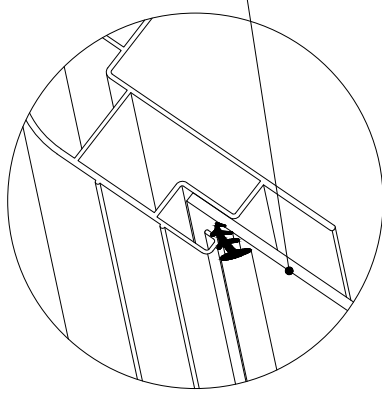
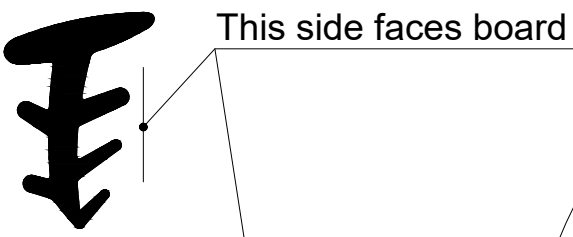
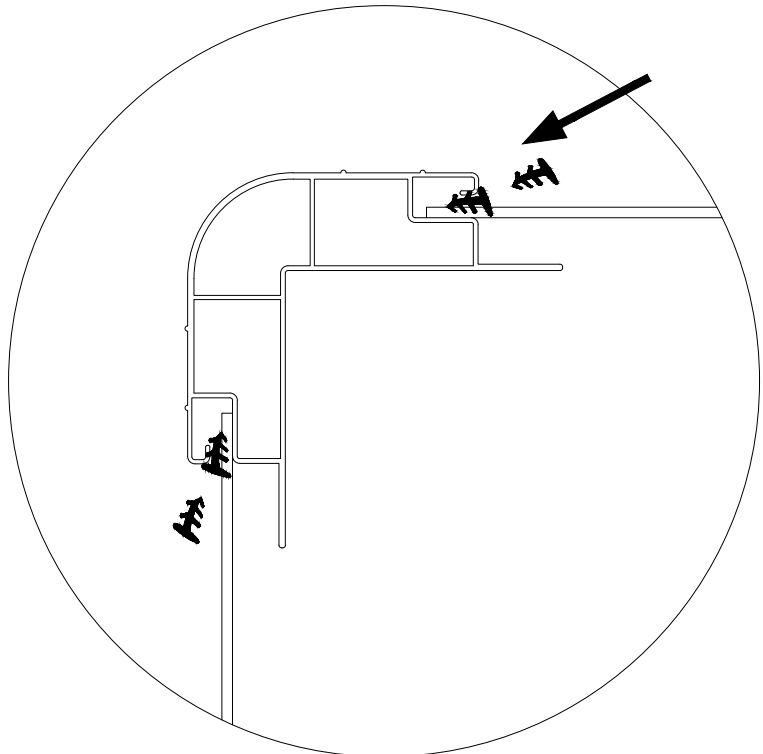
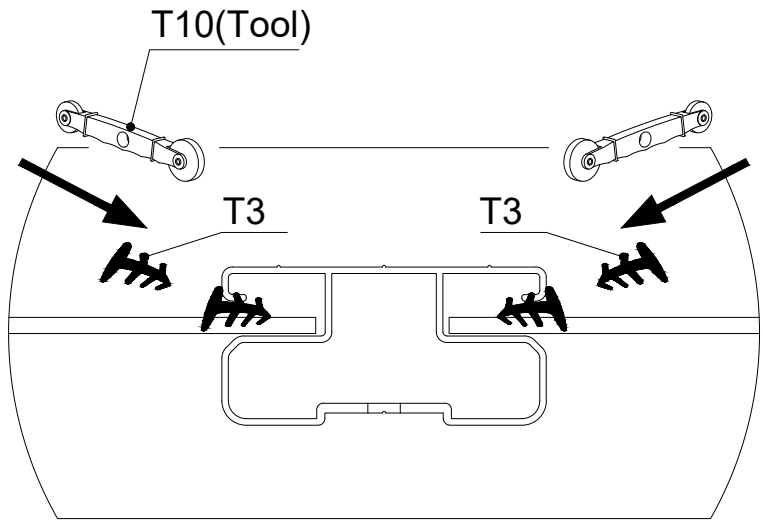
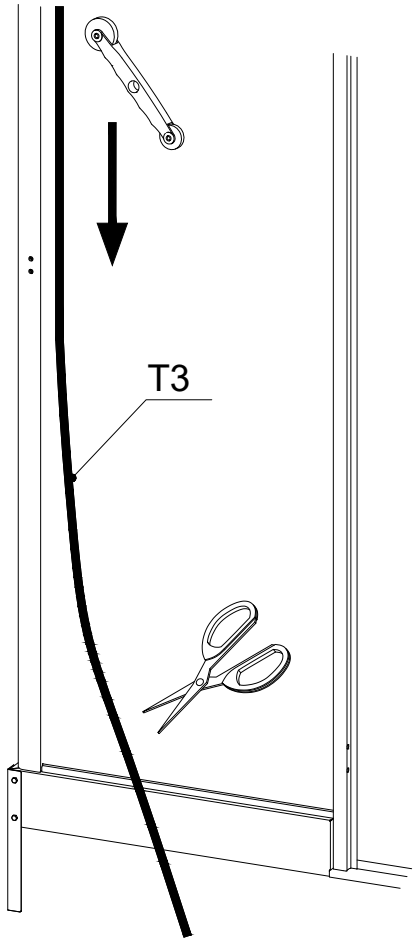
Part	Label	Qty
	T10	1

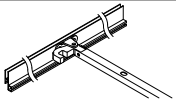
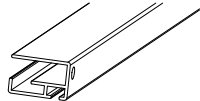
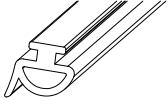
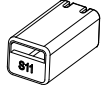

Part	Label	Qty
	Z37	2
	A40	4
	T1	1
	S11	2

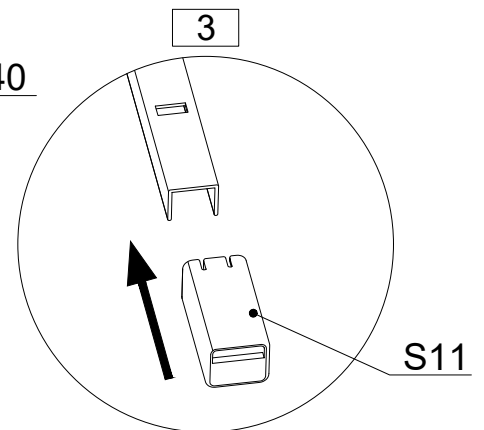
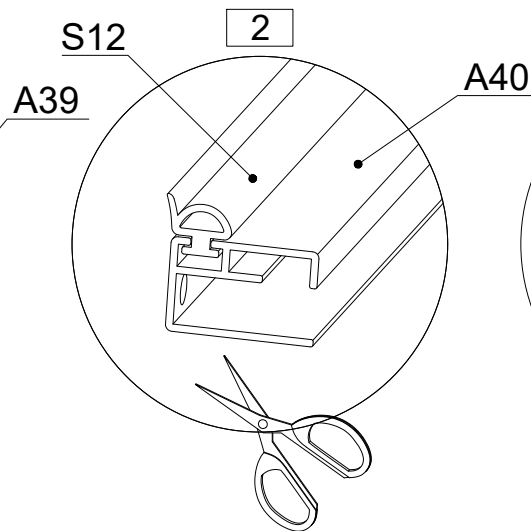
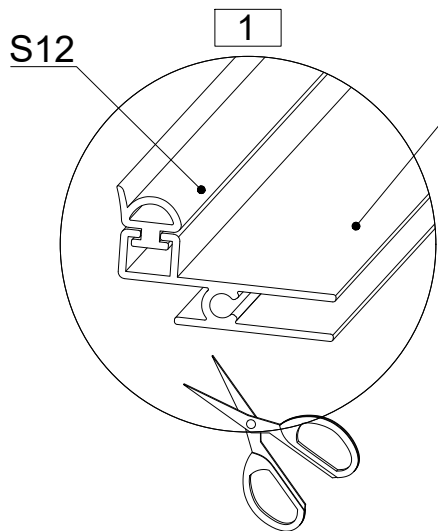
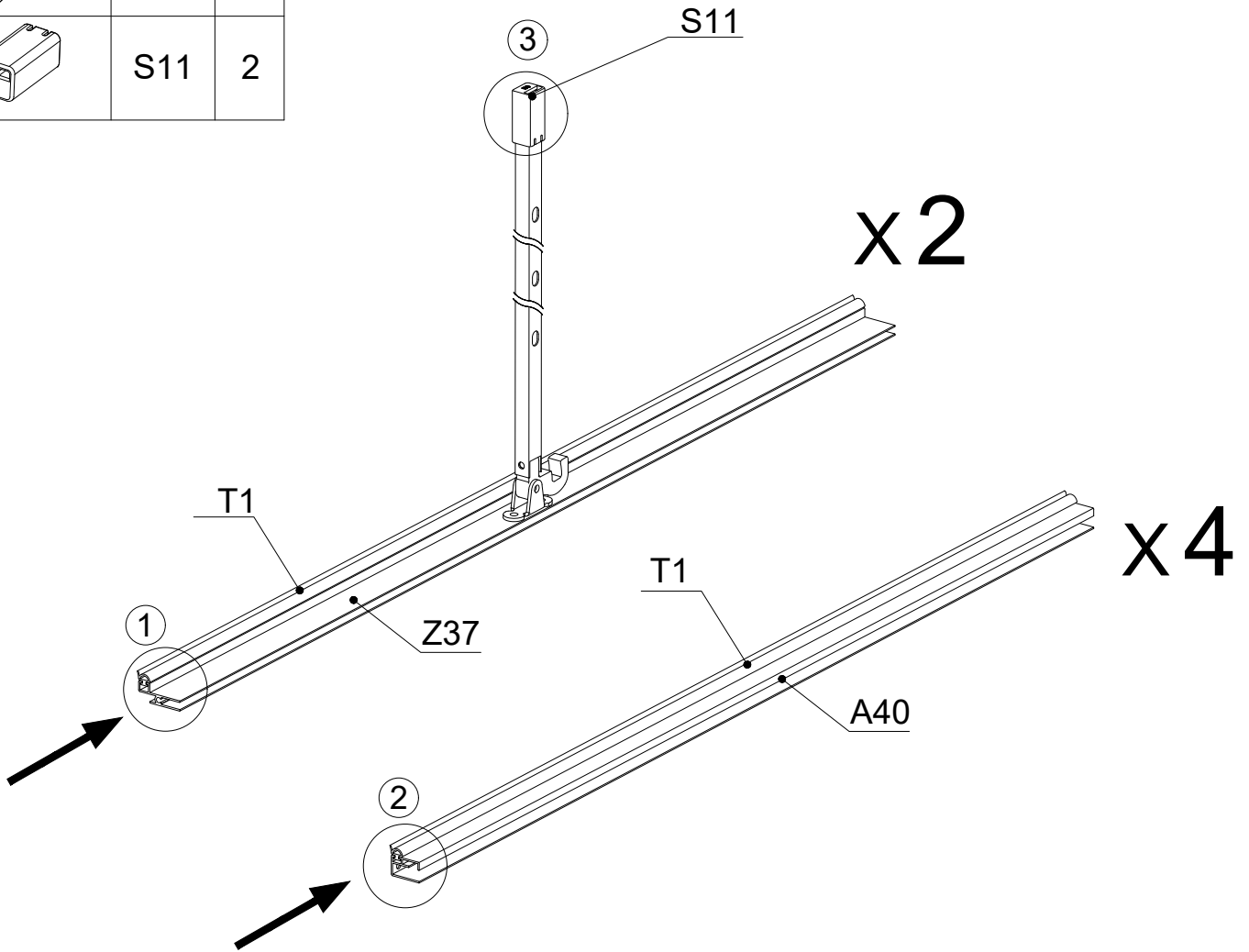
# Vent window assembly

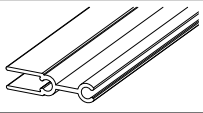

Part	Label	Qty
	A41	2
	N3	2
	F4	8
	ST4.2X10	

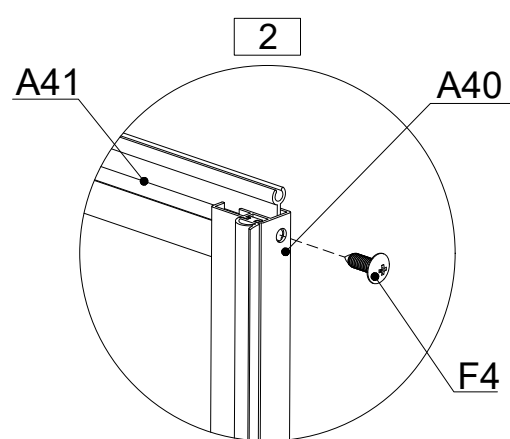
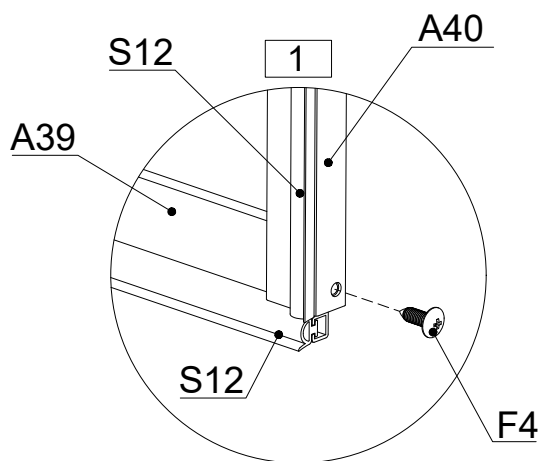
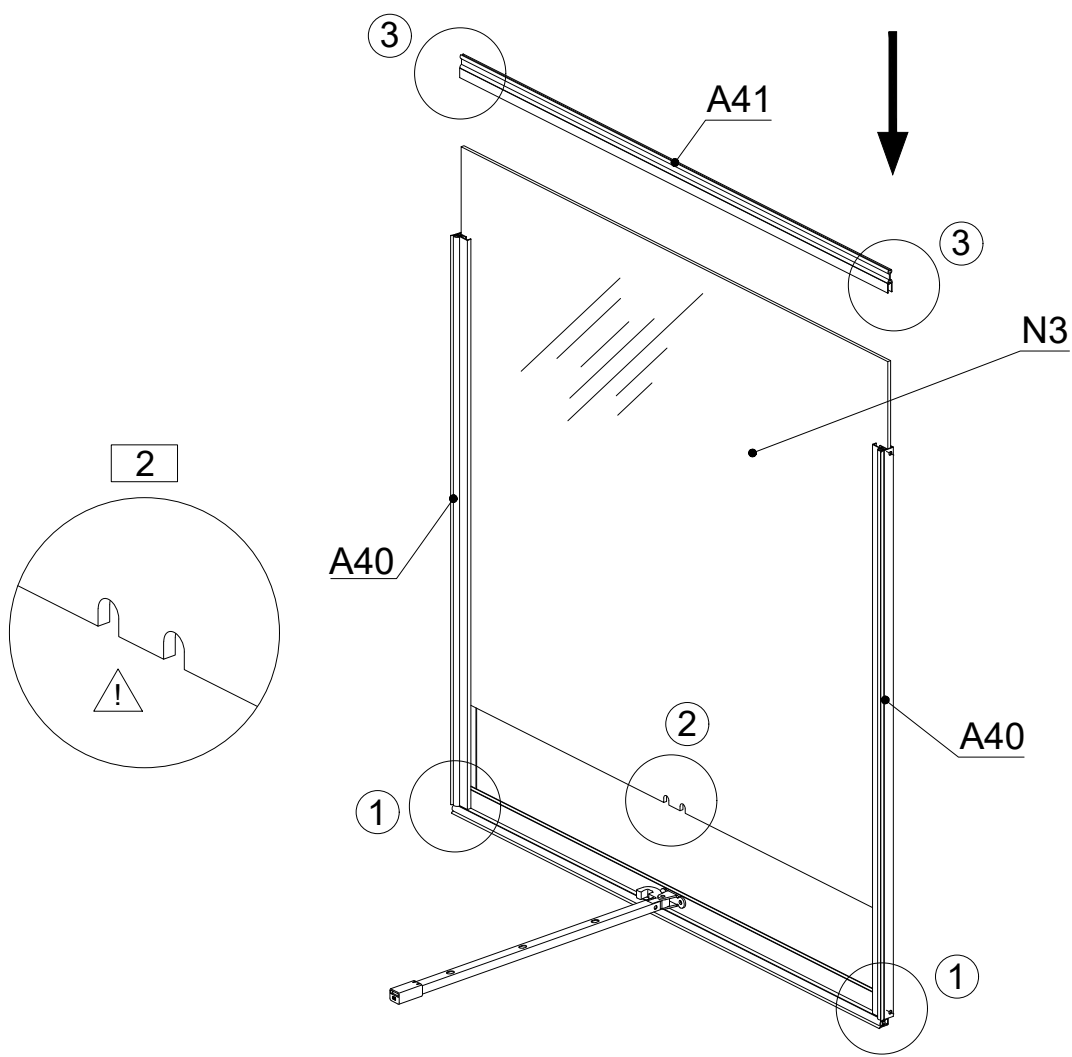
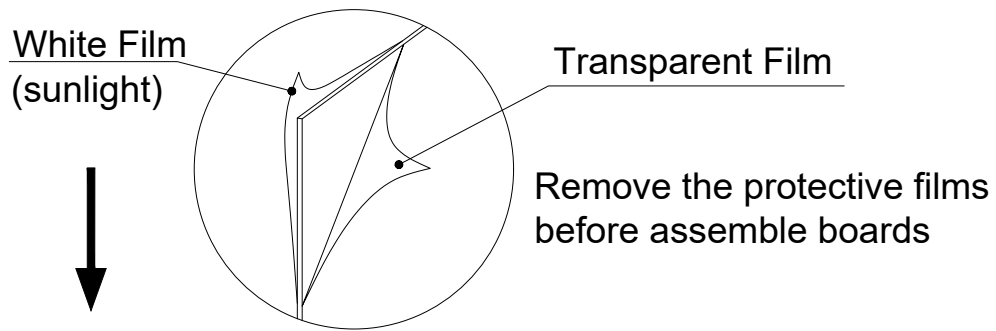

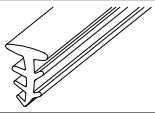
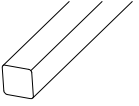
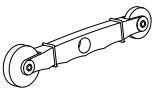

Part	Label	Qty
	T3	1
	T4	1
	T10	1

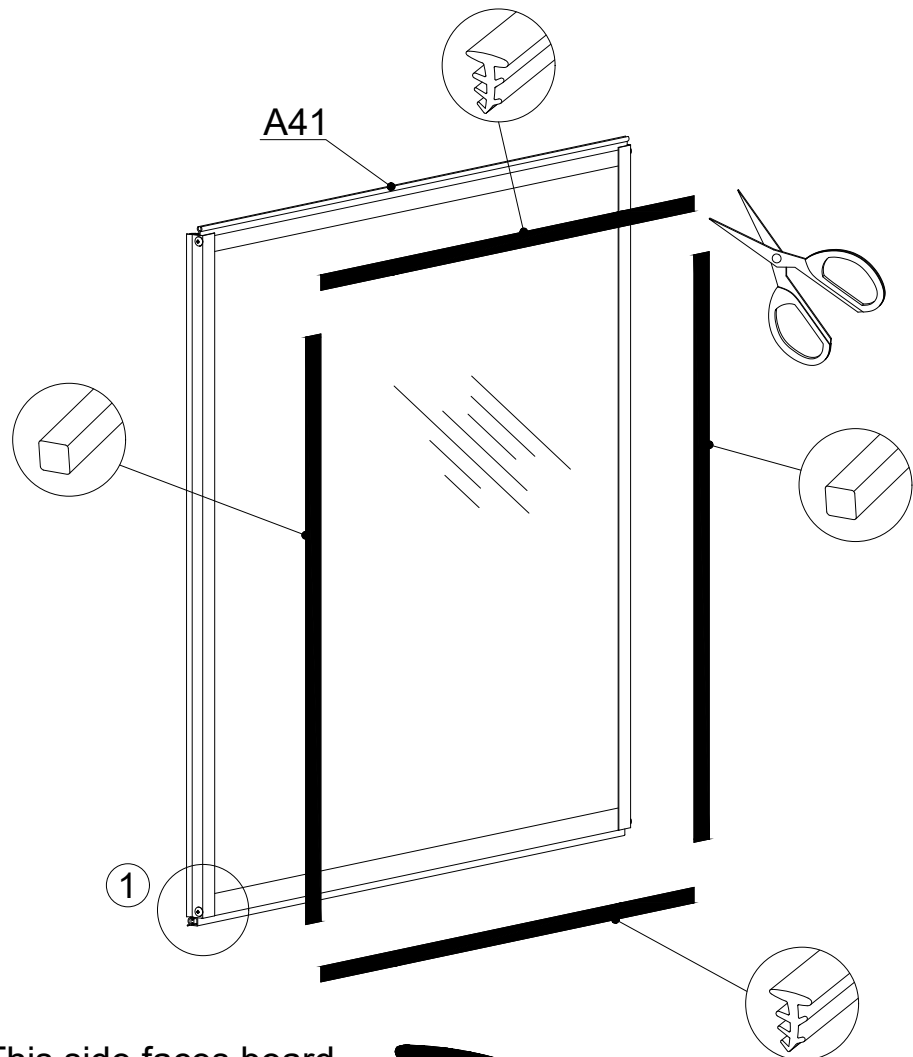
x2



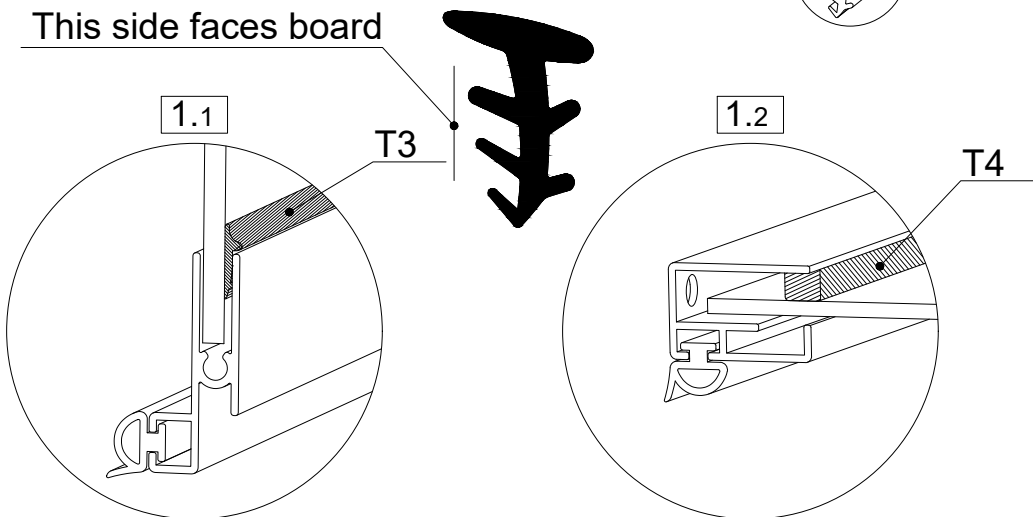

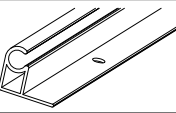
This side faces board



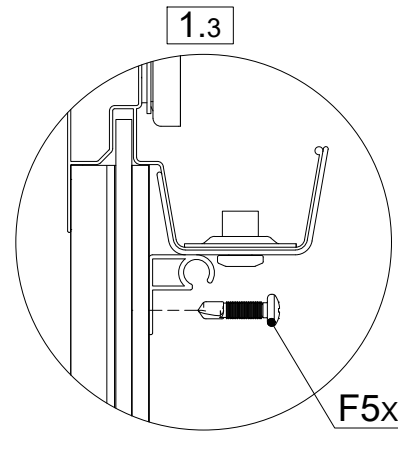
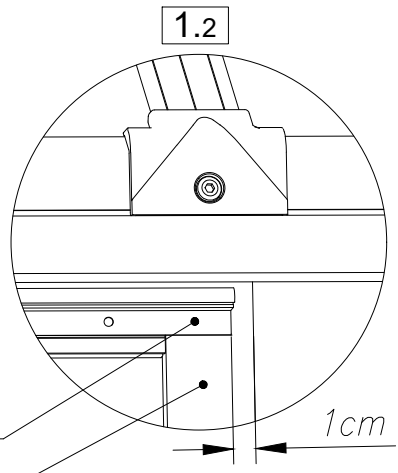
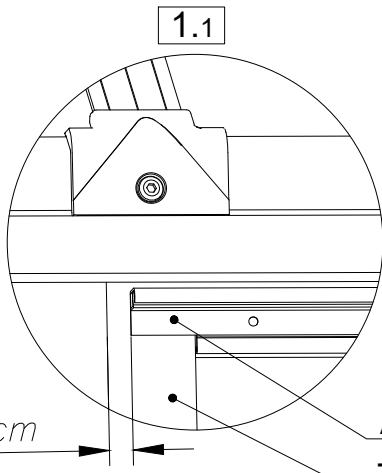
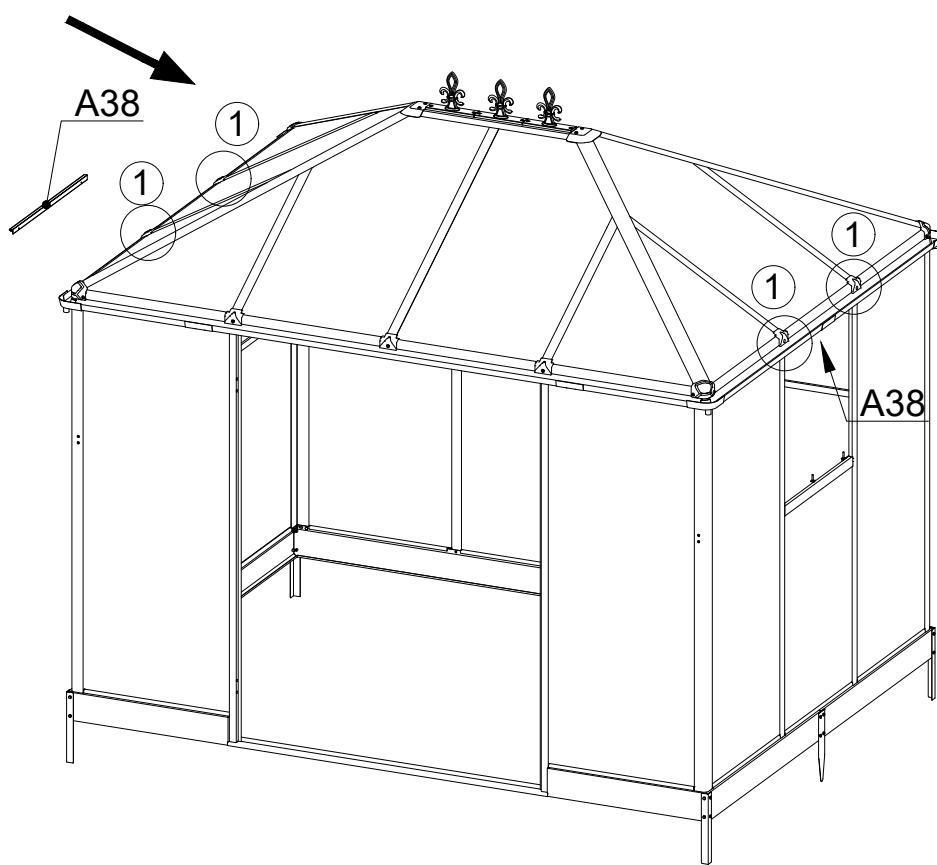



Part	Label	Qty
	A38	2
	F5 ST4.2X13	4

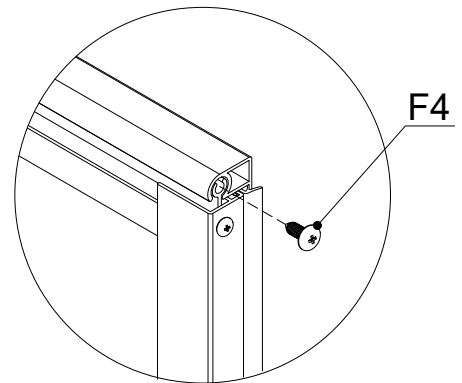
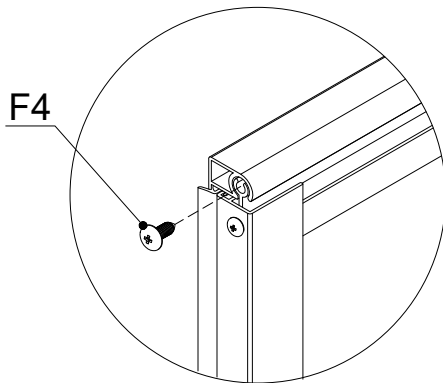
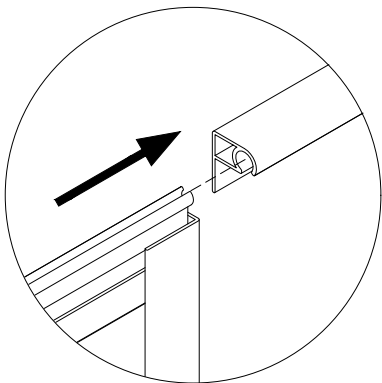
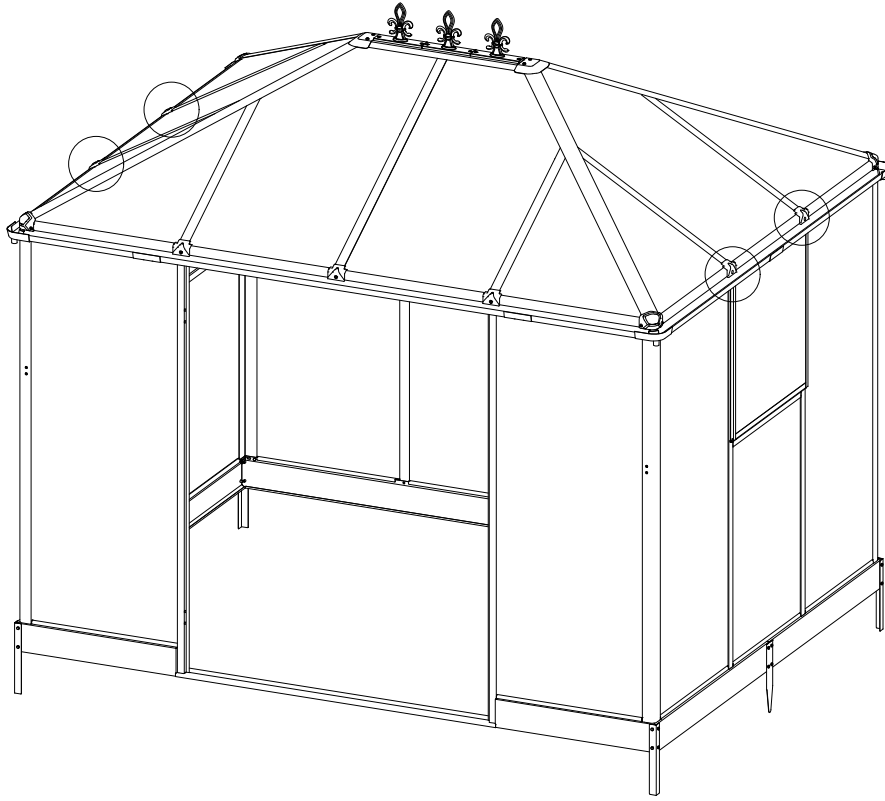

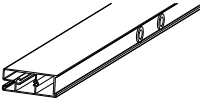
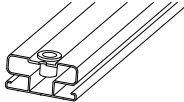

Part	Label	Qty
	Window	2
	F4	4
	ST4.2X10	



# Door assembly

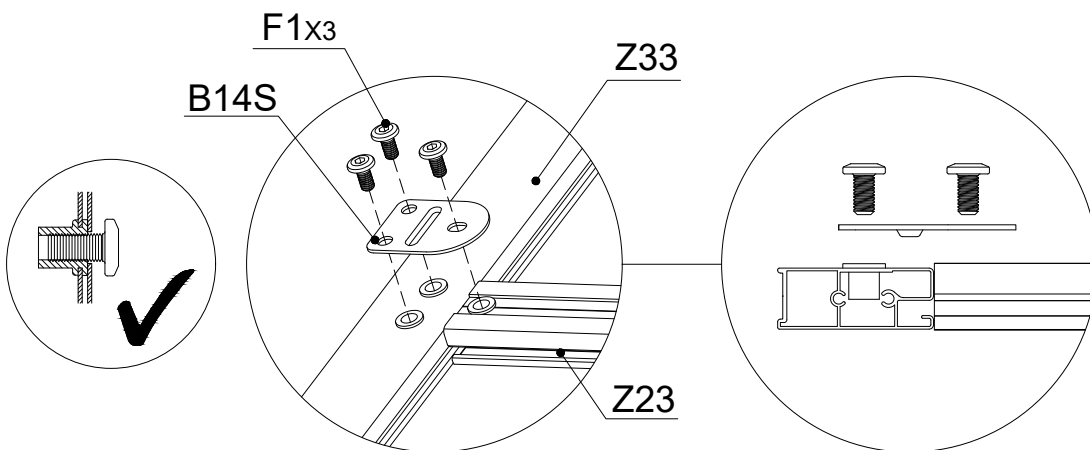
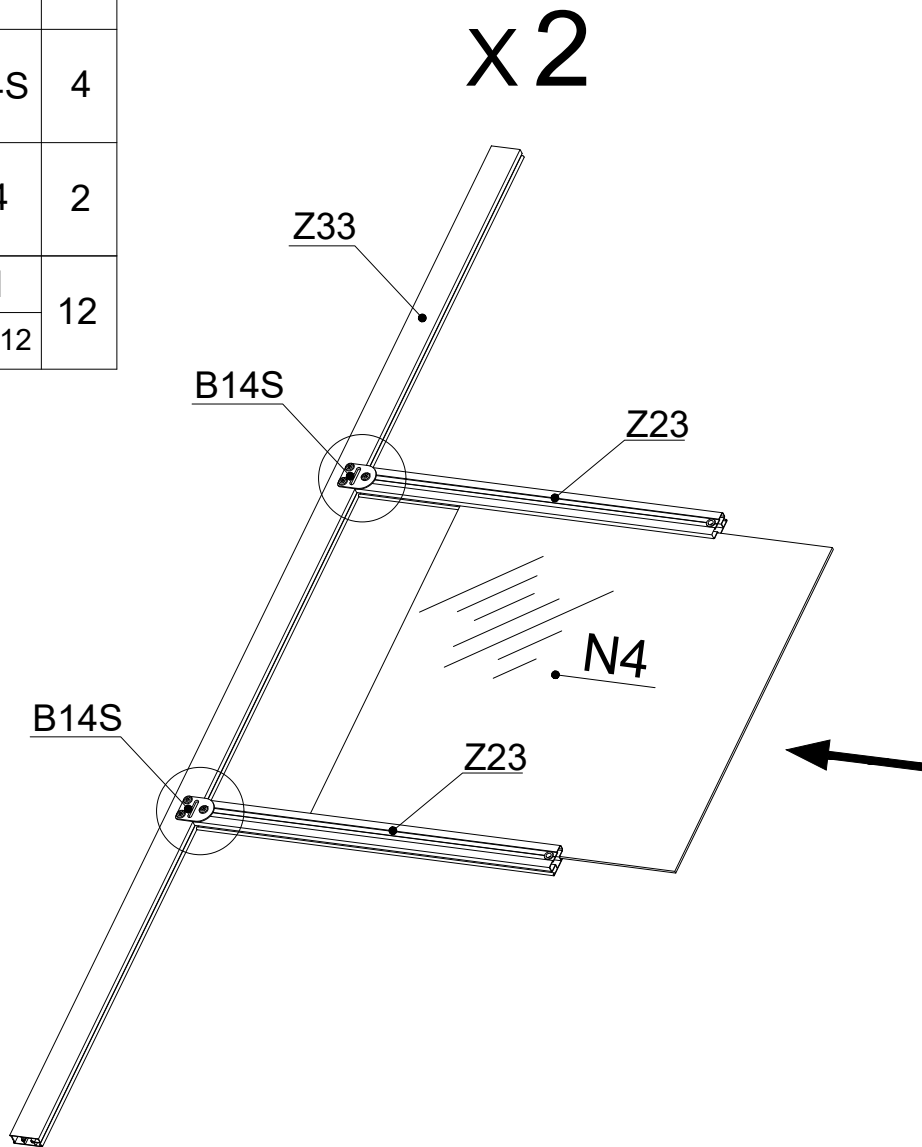

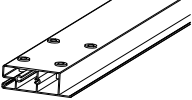
Part	Label	Qty
	Z33	2
	Z23	4
	B14S	4
	N4	2
	F1	12
	M6X12	

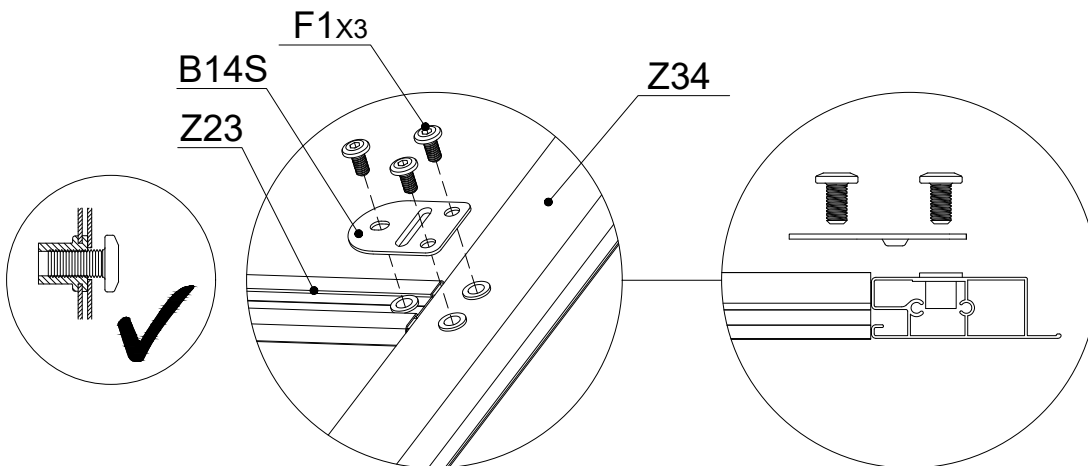
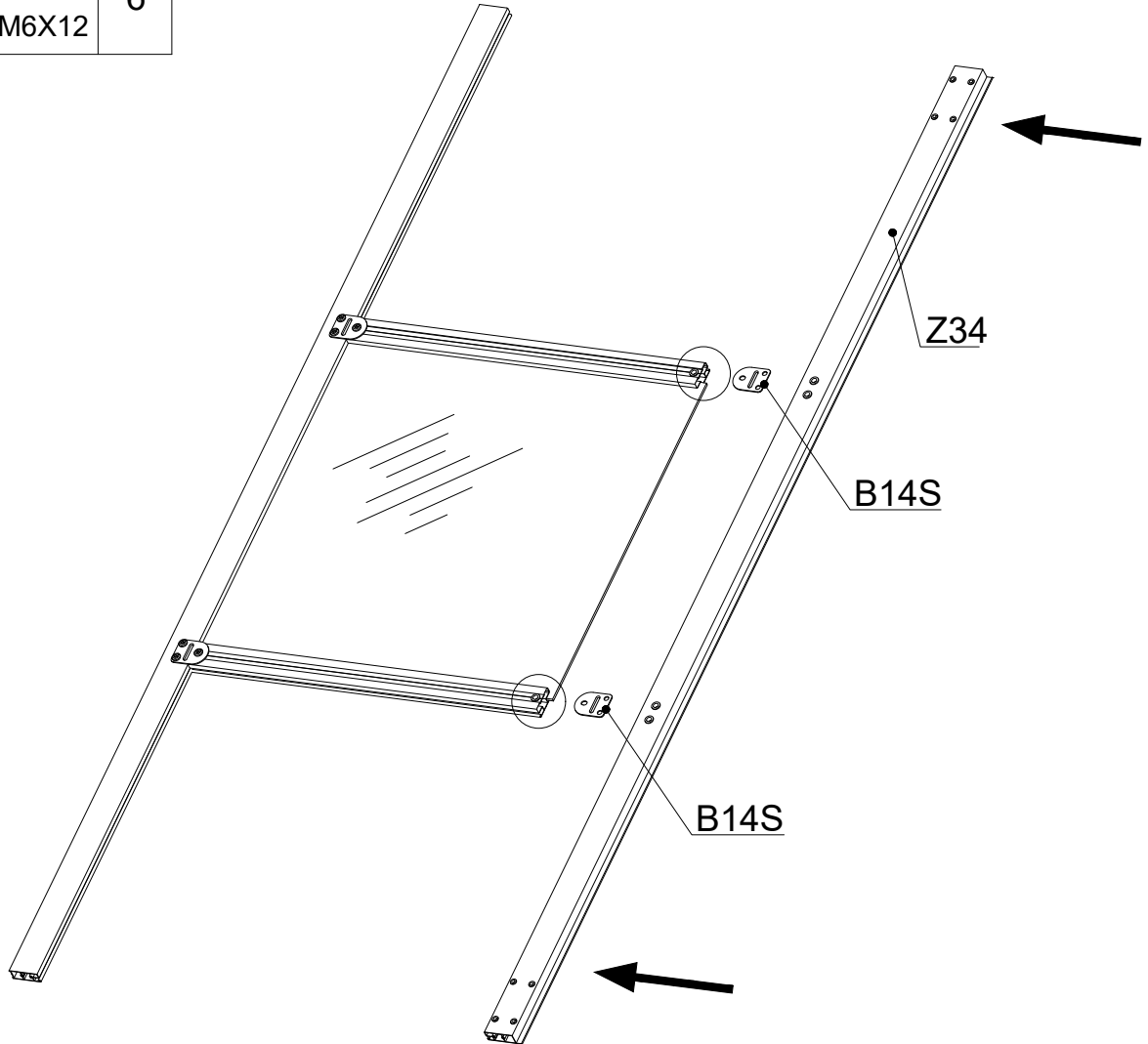

Part	Label	Qty
	Z34	1
	B14S	2
	F1	6
	M6X12	

# Left door assembly

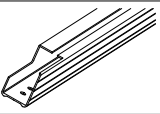
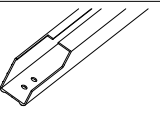

Part	Label	Qty
	N4	2
	A36	1
	A37	1
	F4 ST4.2X10	8

# Left door assembly

Make sure the door frame upright.

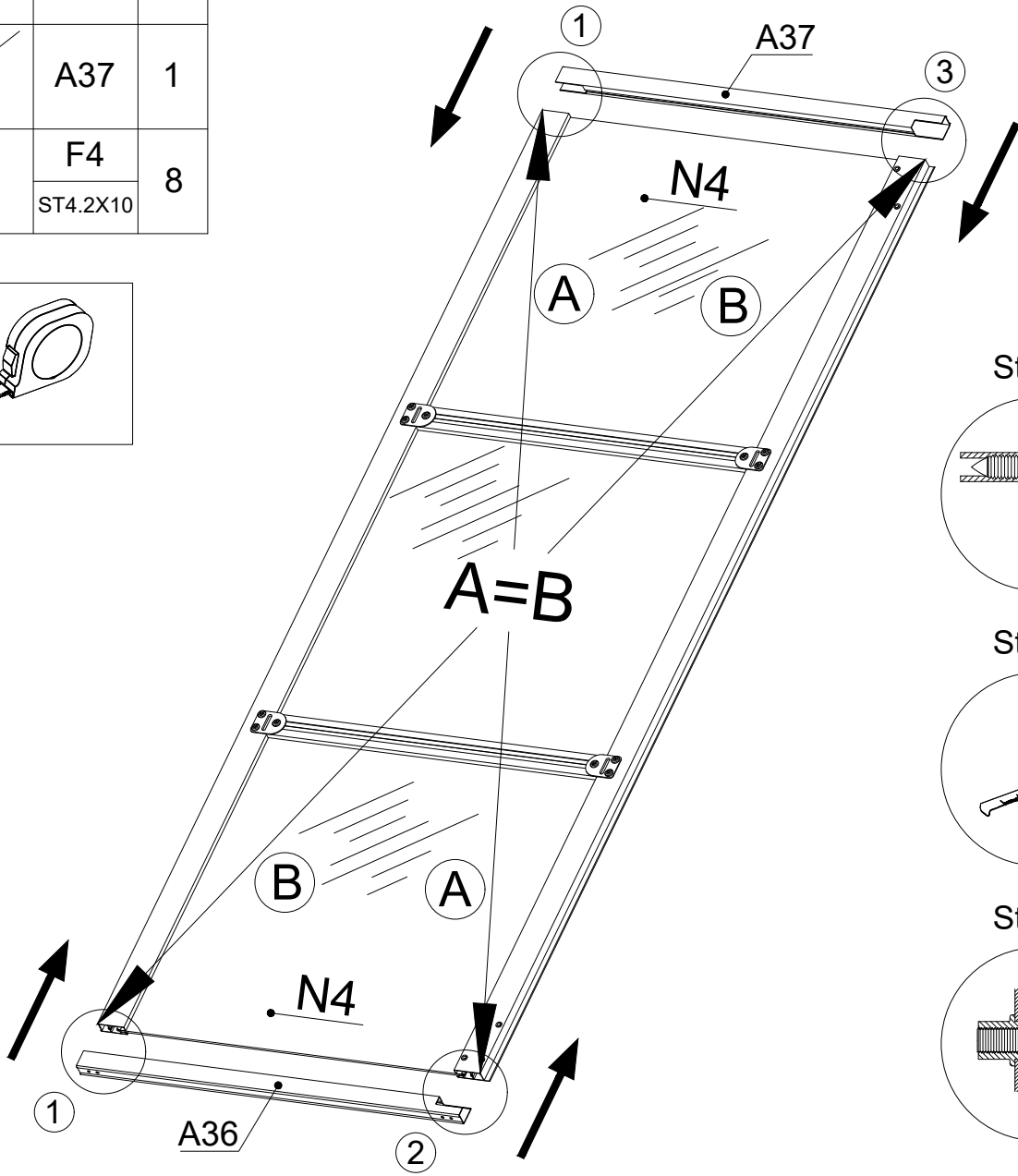
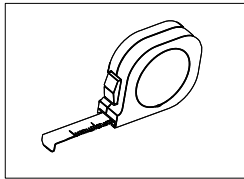

Step 1

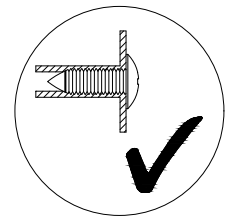

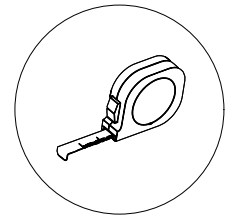

Step 2

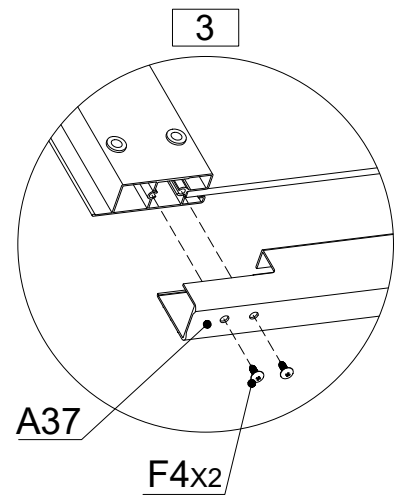
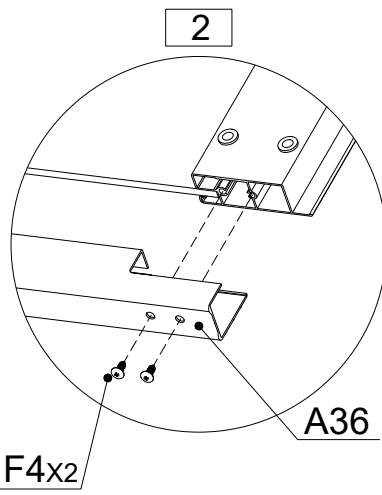
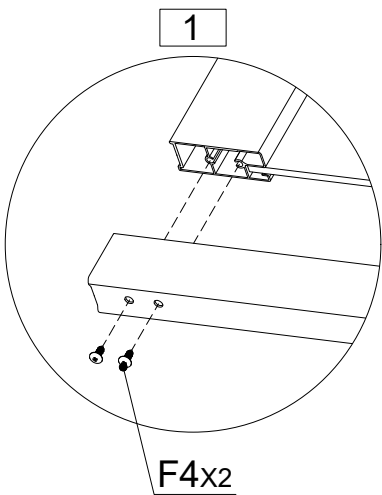
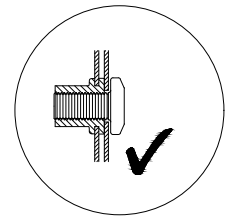

Step 3

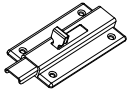



Part	Label	Qty
	T9	2
	F3	8
	M4X12	

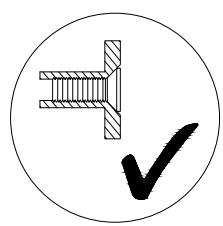
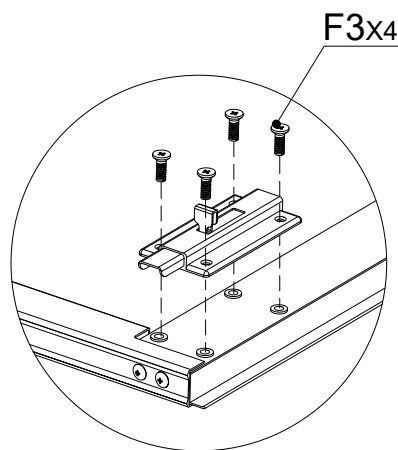
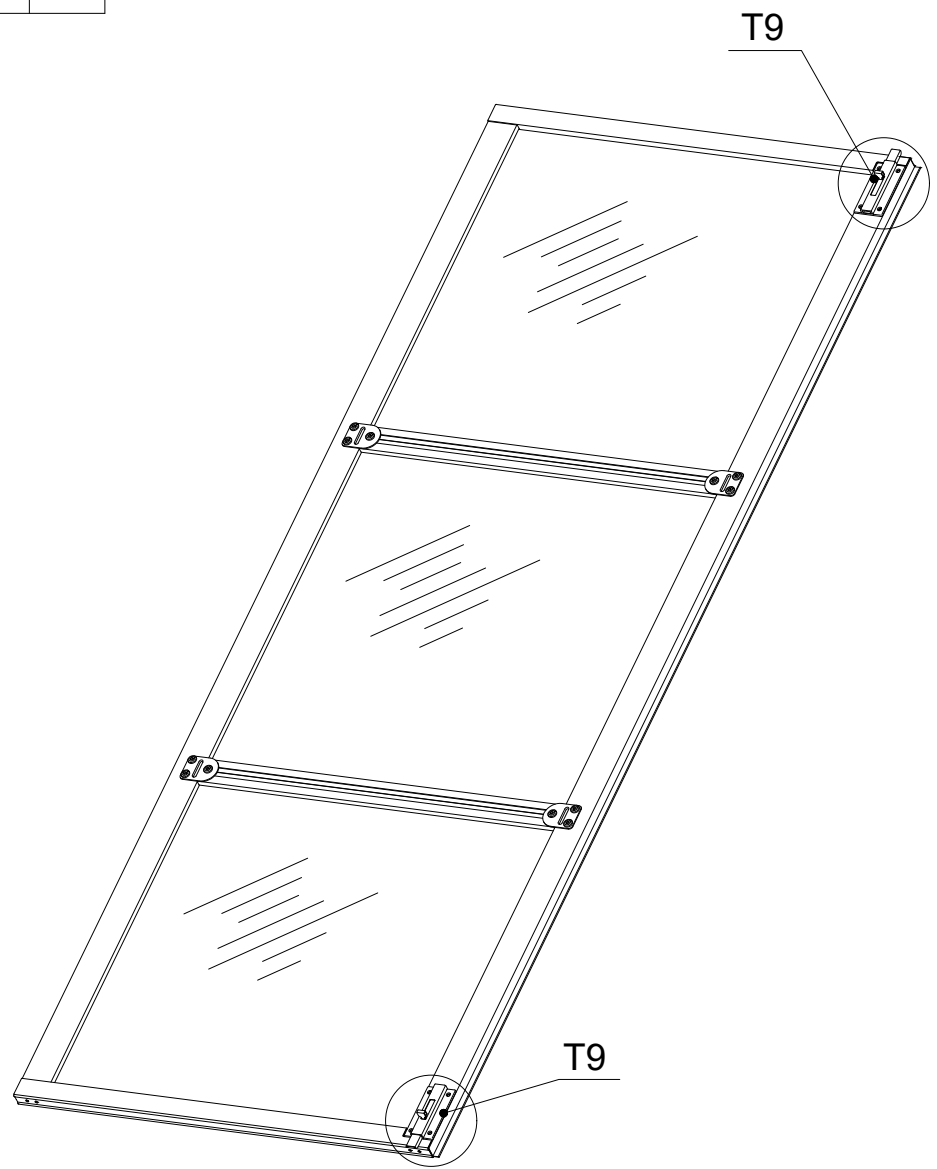

# Left door assembly

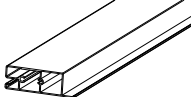

# Right door assembly

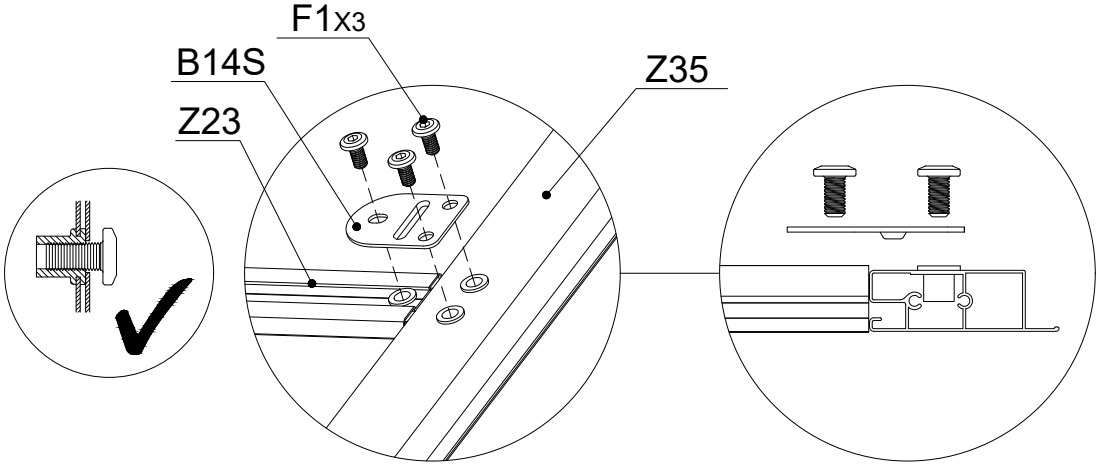
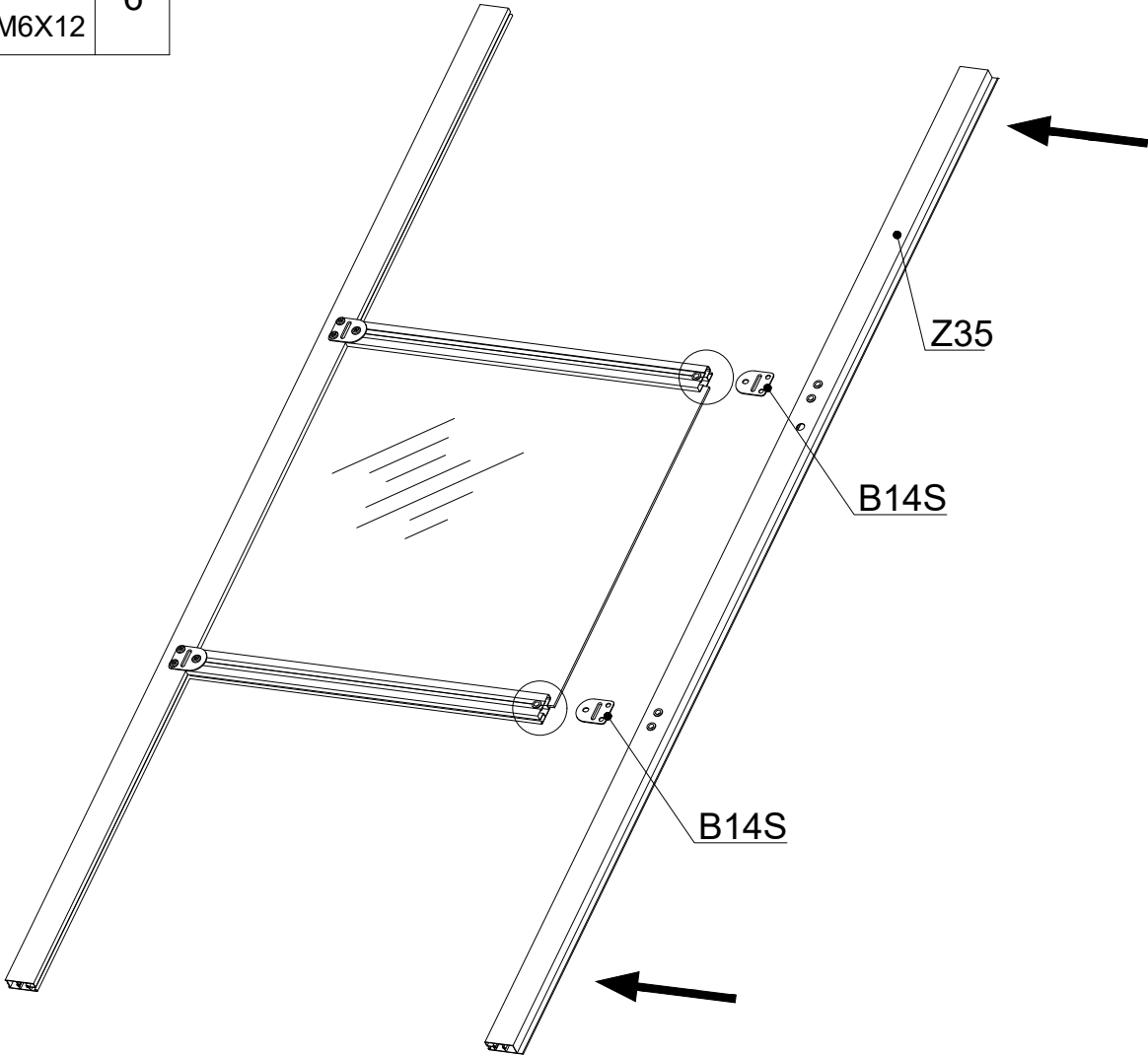
Part	Label	Qty
	Z35	1
	B14S	2
	F1	6
	M6X12	

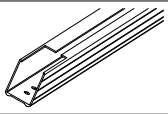

Part	Label	Qty
	N4	2
	A35	2
	F4	8
	ST4.2X10	

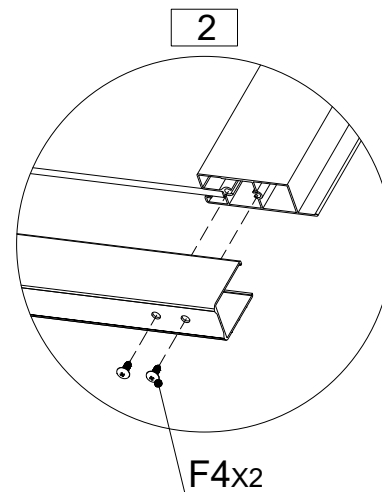
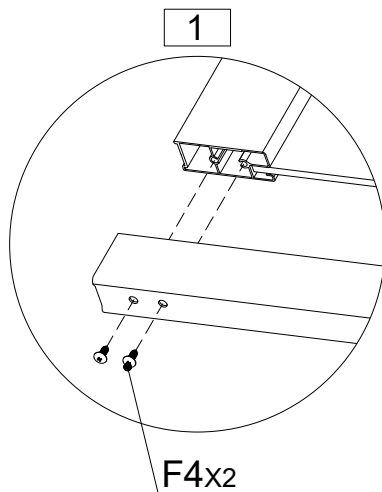
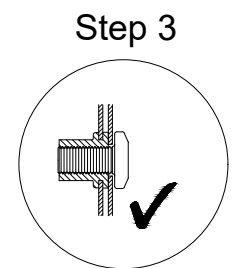
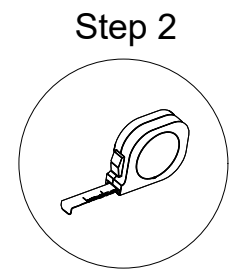
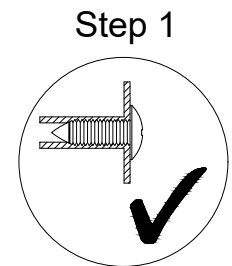
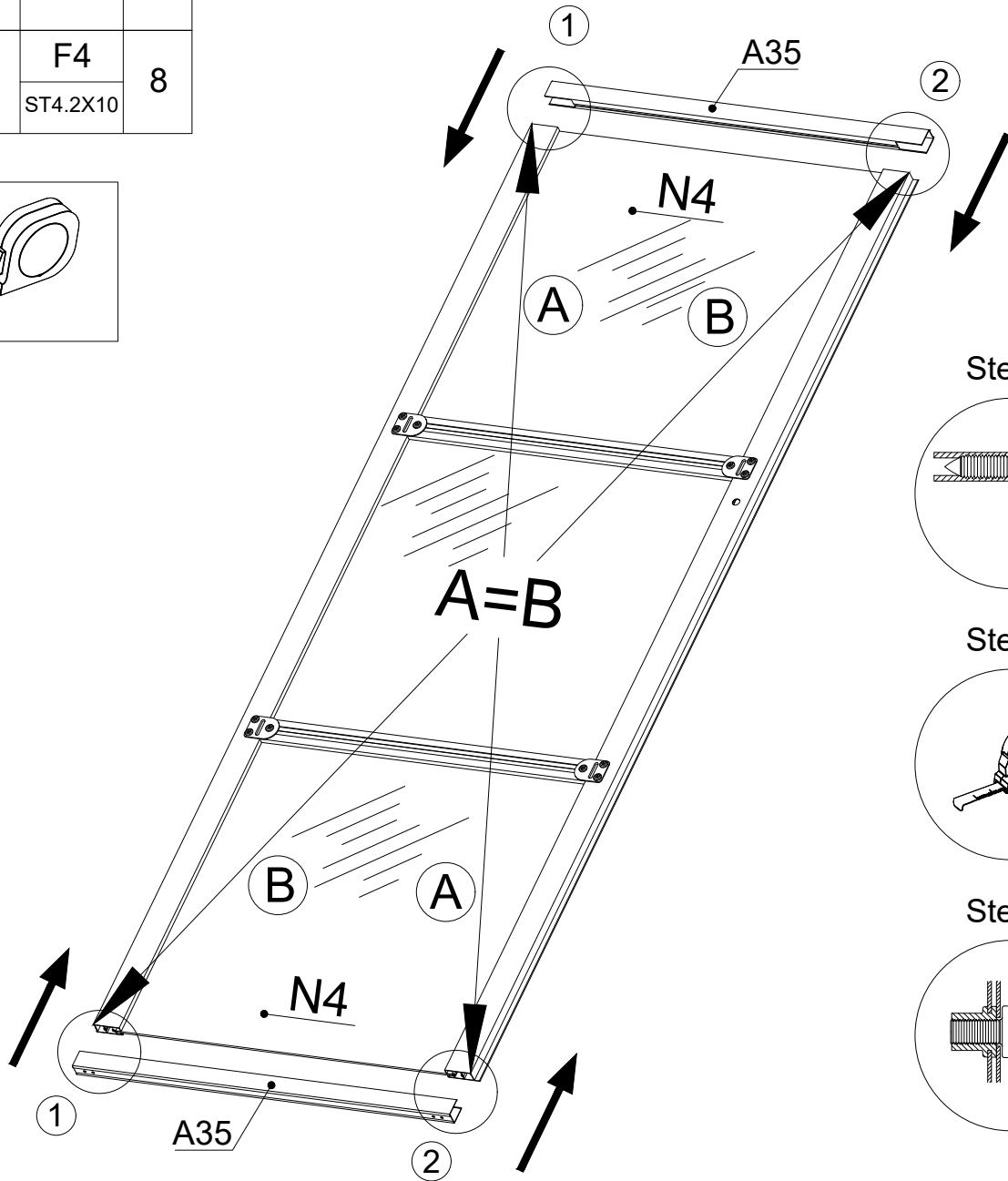
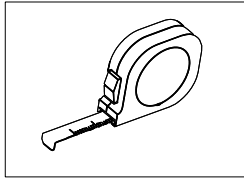

# Right door assembly

Make sure the door frame upright.

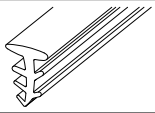
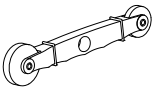

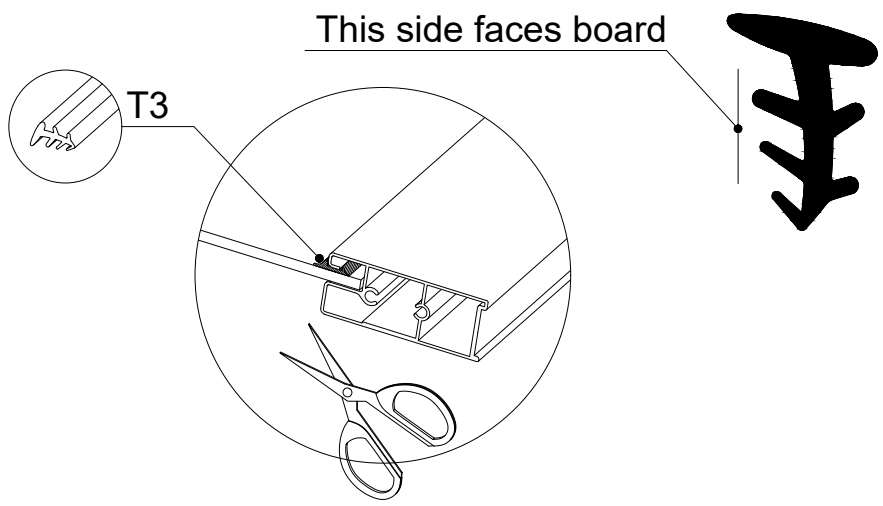
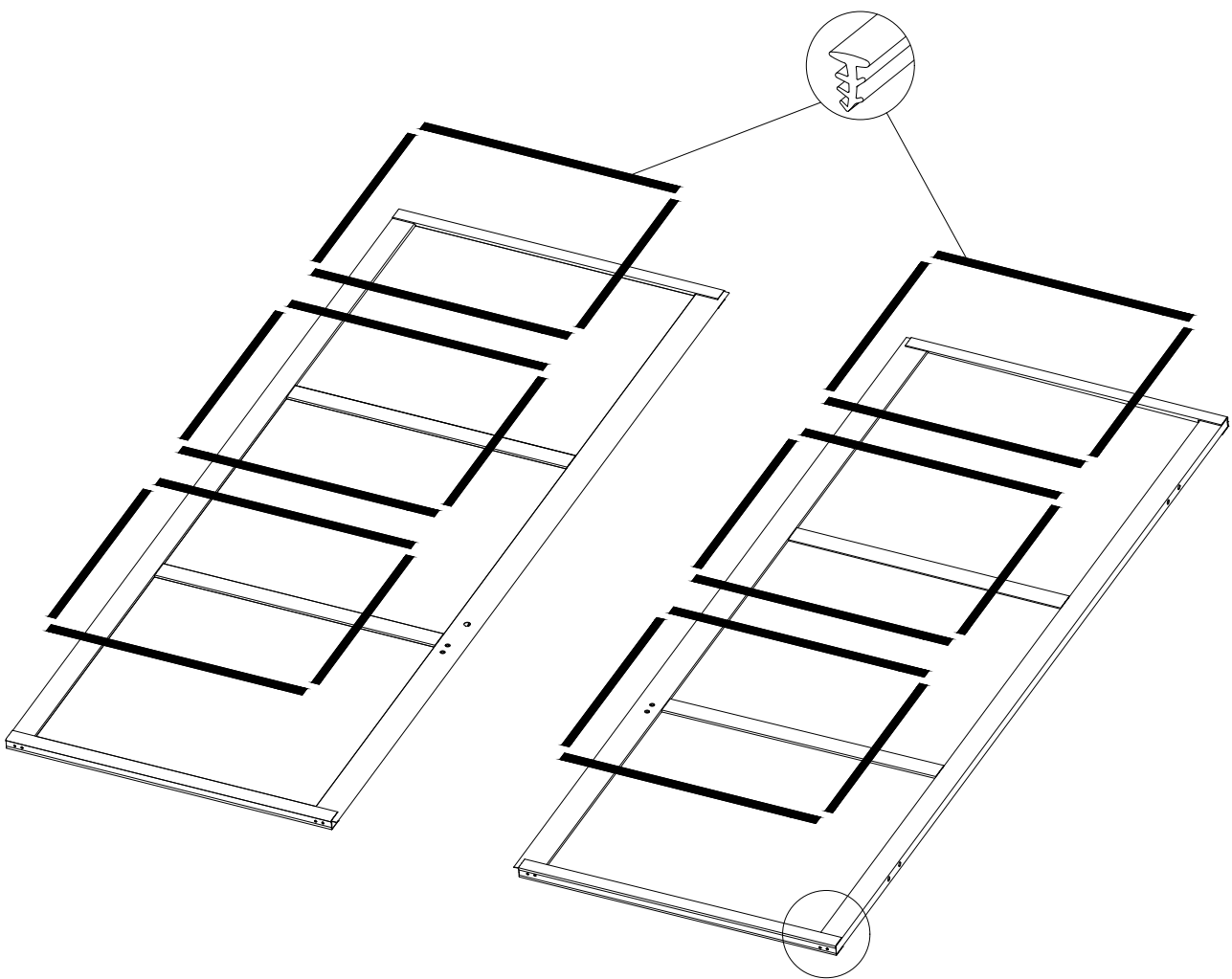

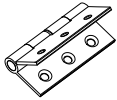
Part	Label	Qty
	T3	1
	T10	1

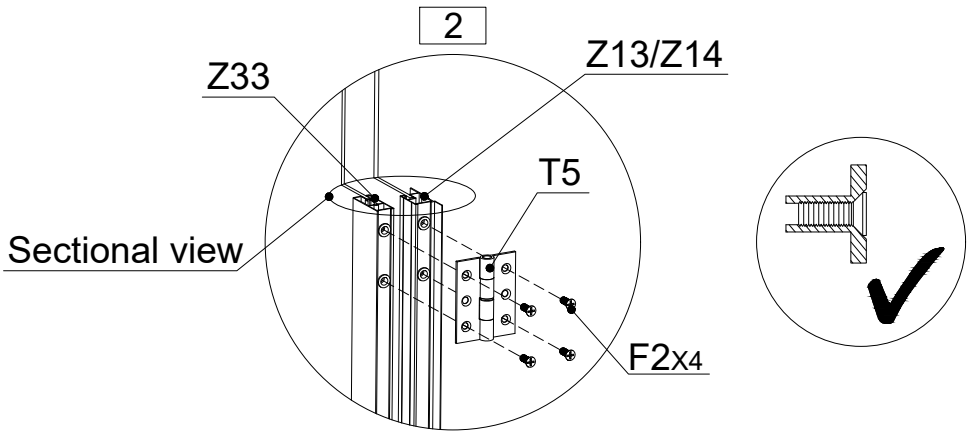
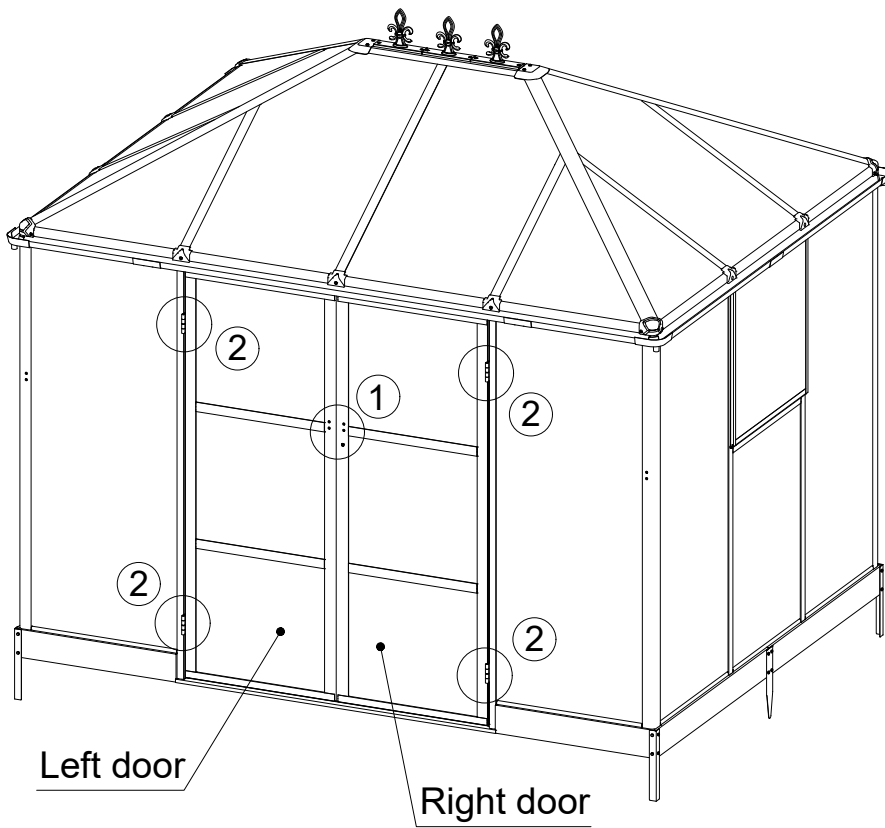
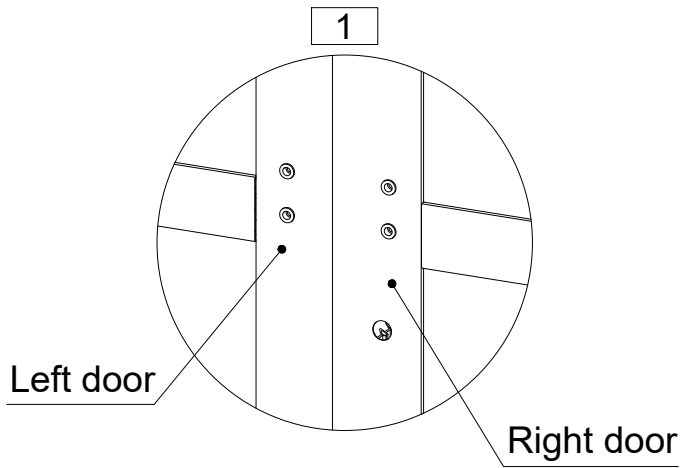

Part	Label	Qty
	T5	4
	F2	16
	M6X12	



Part	Label	Qty
	T8	1
	F6	6
	ST3.5X16	

# Doorknob assembly

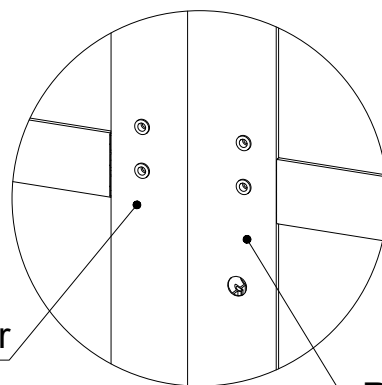

Left door

Right door

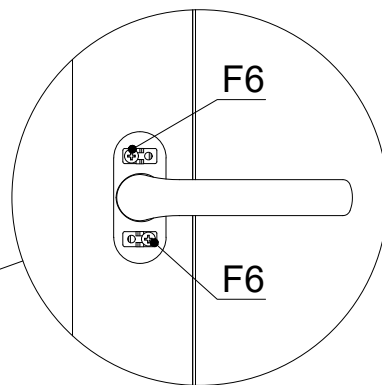
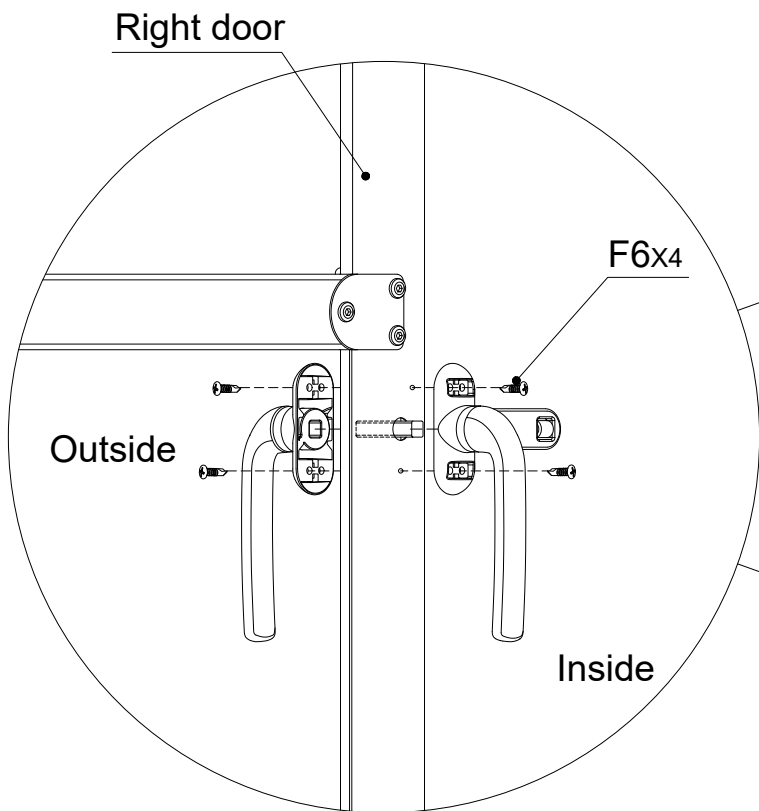

Outside

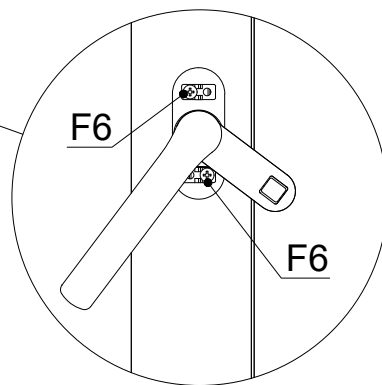

Inside

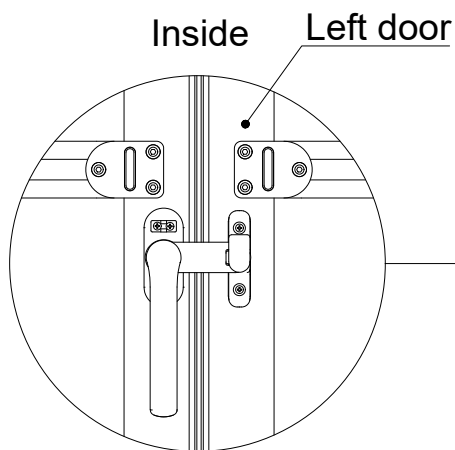



Inside

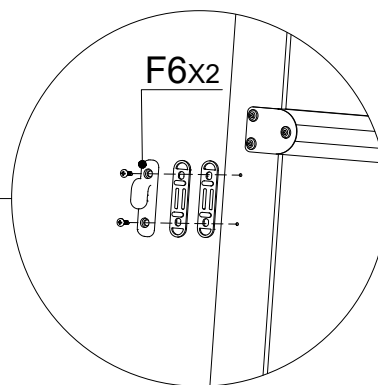

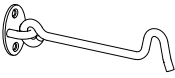

Left door

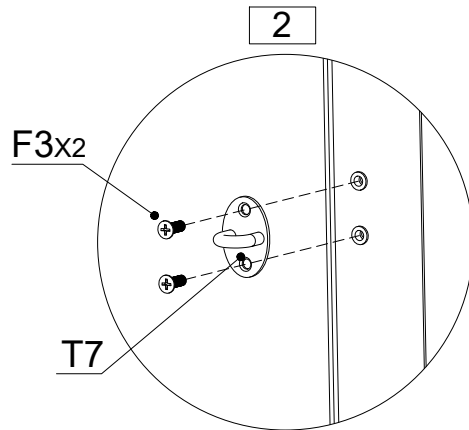
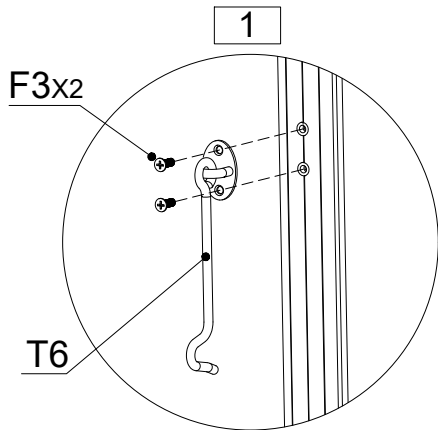
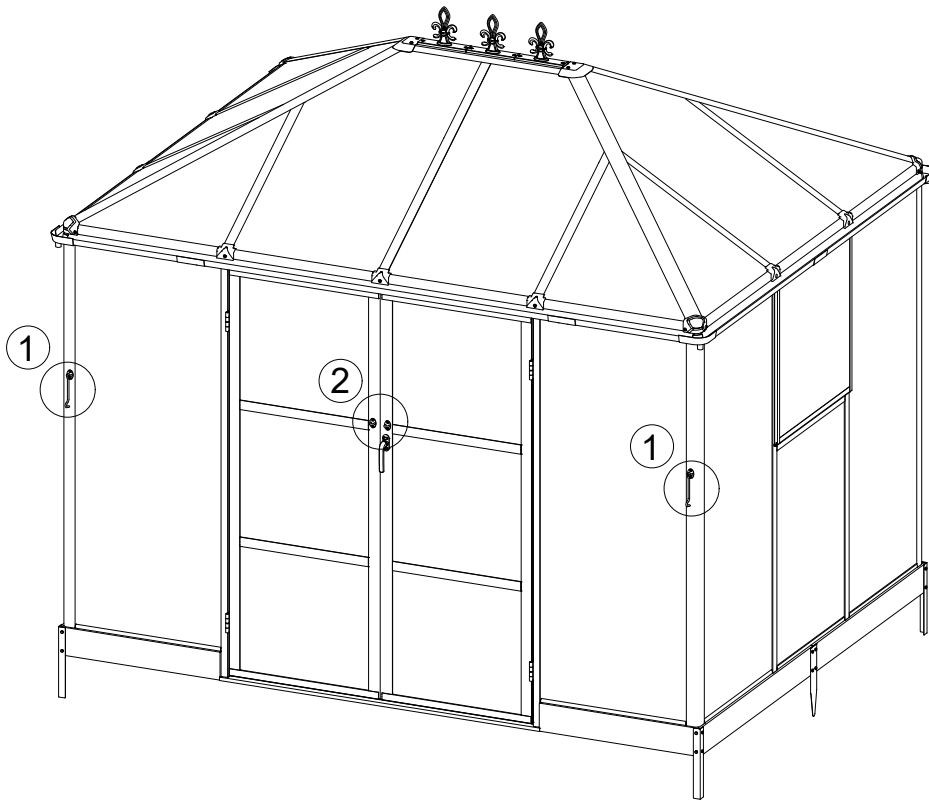

F6x2

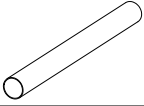
Part	Label	Qty
	T6	2
	T7	2
	F3	8
	M4X12	



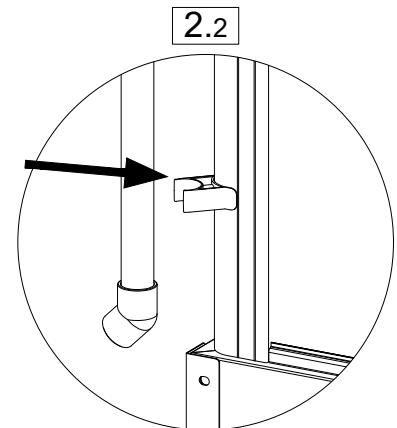
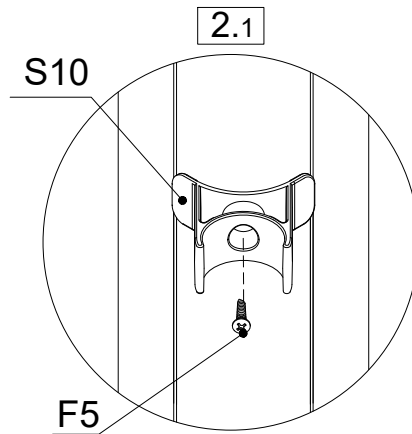
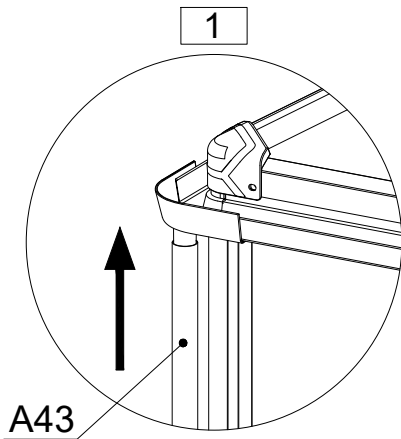
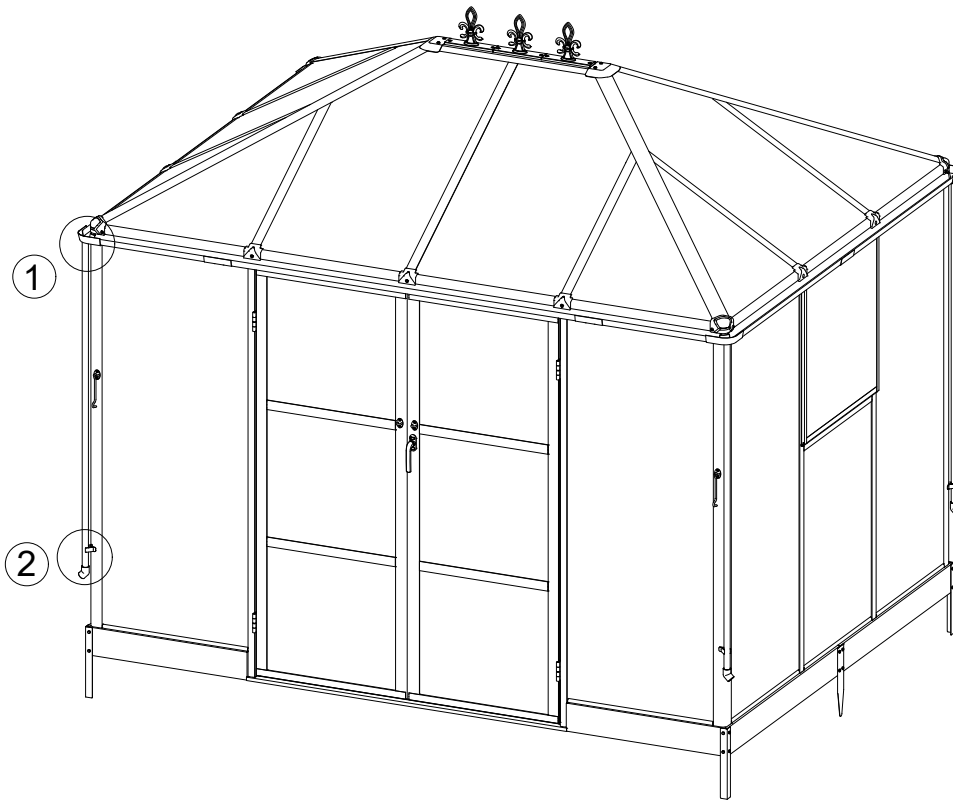
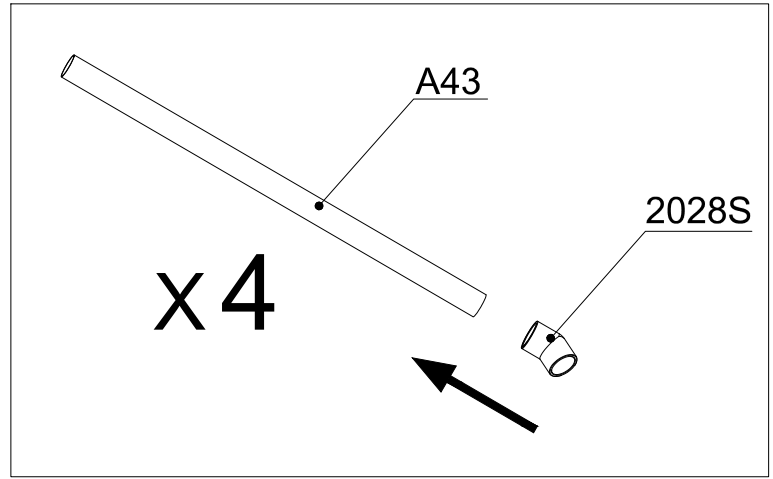

Part	Label	Qty
	A43	4
	2028S	4
	S10	4
	F5 ST4.2X13	4

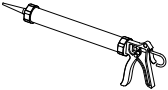

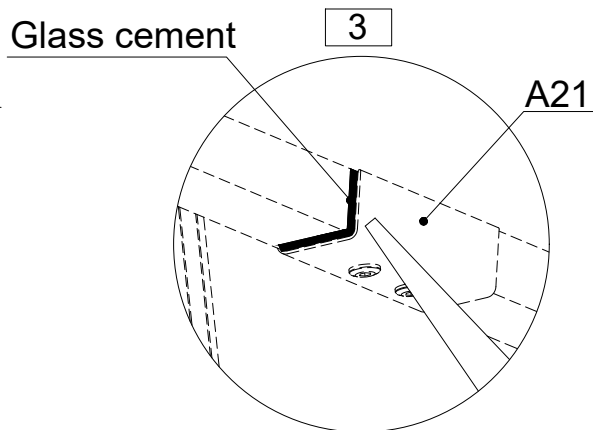
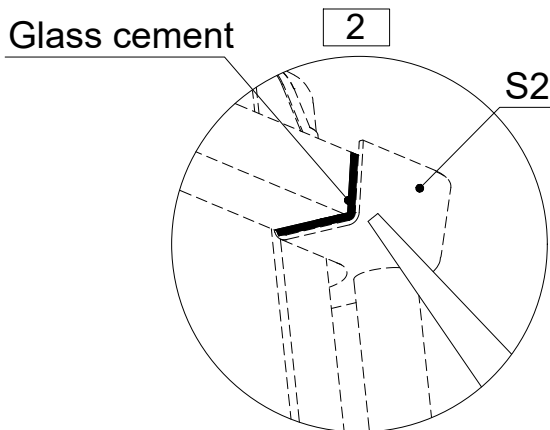
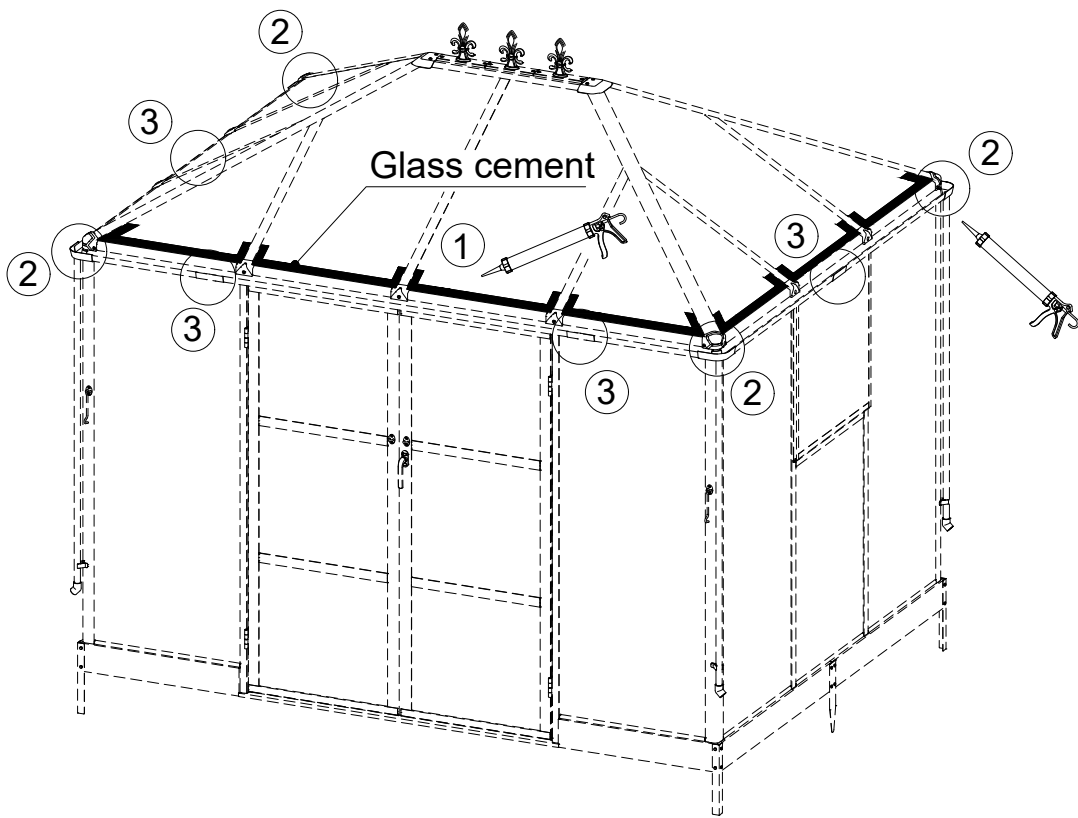
Part	Label	Qty
	/	1

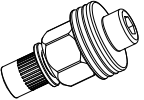
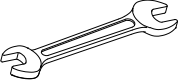

Part	Label	Qty
	T11	1
	T12	1
	T13	1
		5

If few of nuts missed,  
please use these tools for riveting.

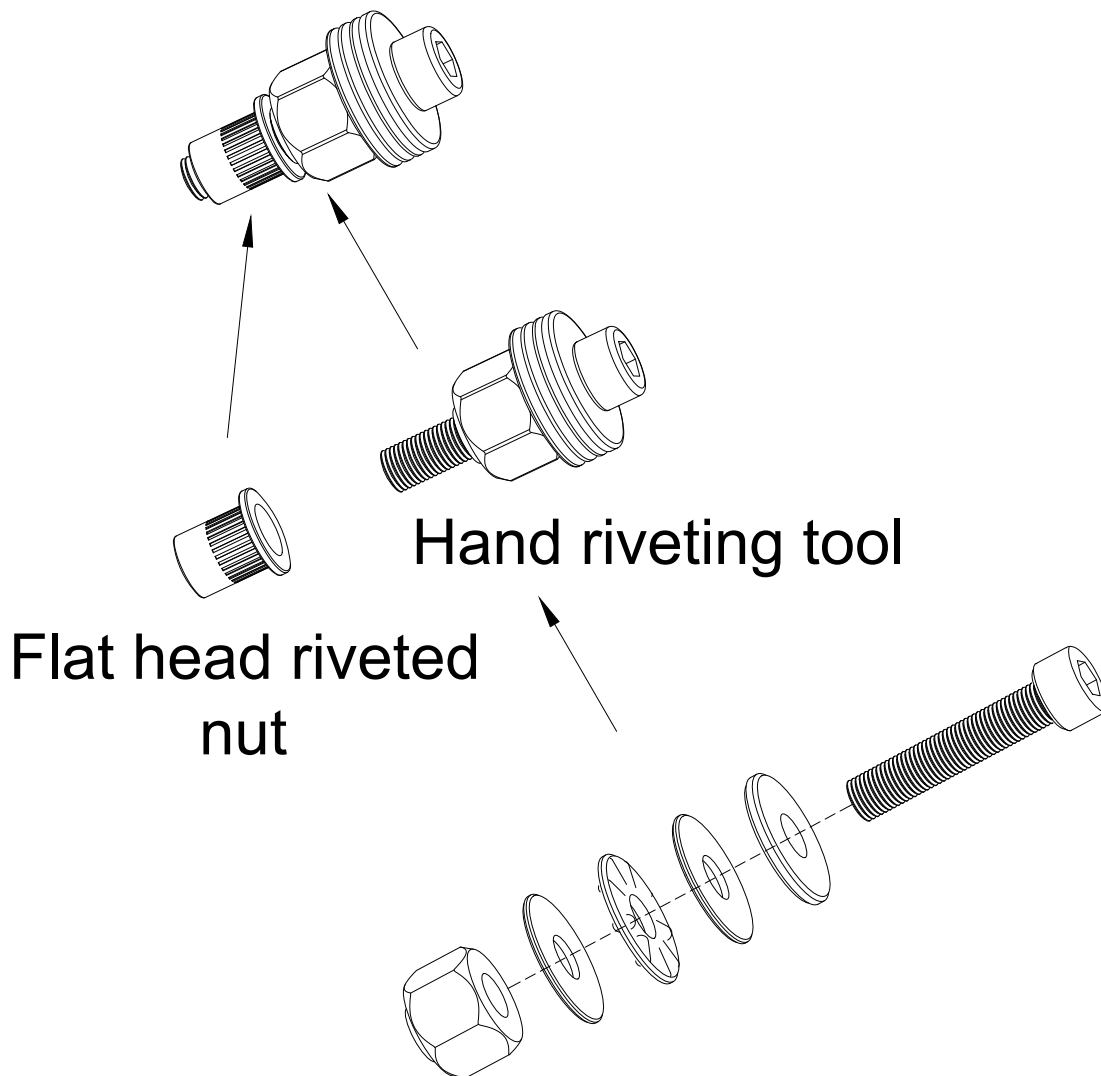

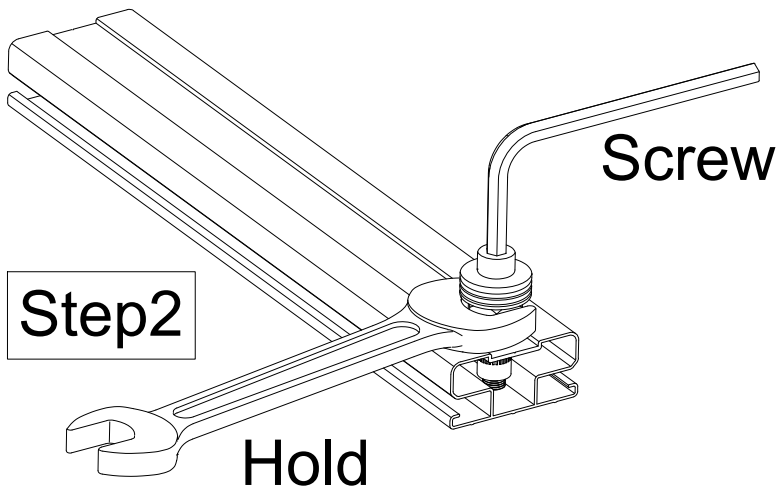
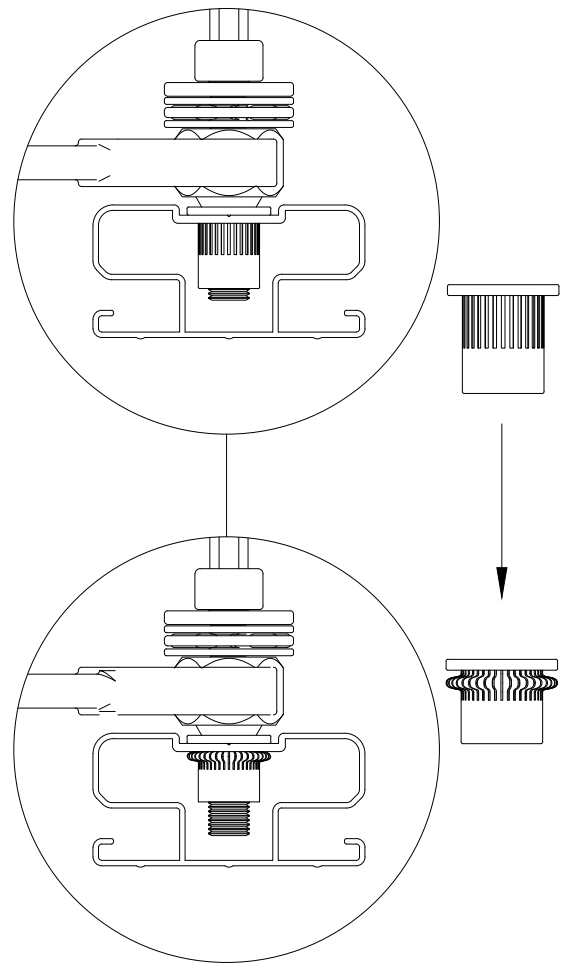
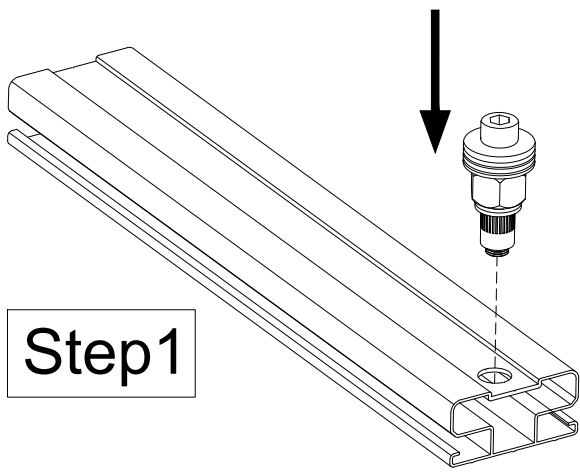

Tips: Fix the rivet nut steady enough with wrench.

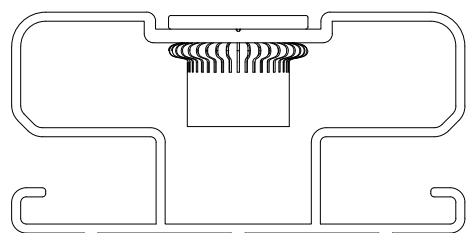
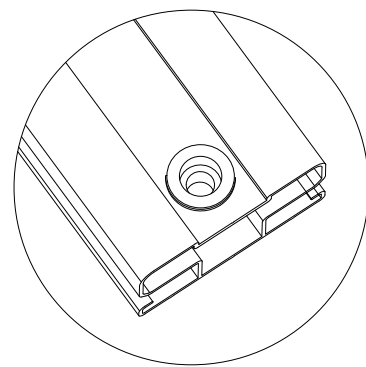
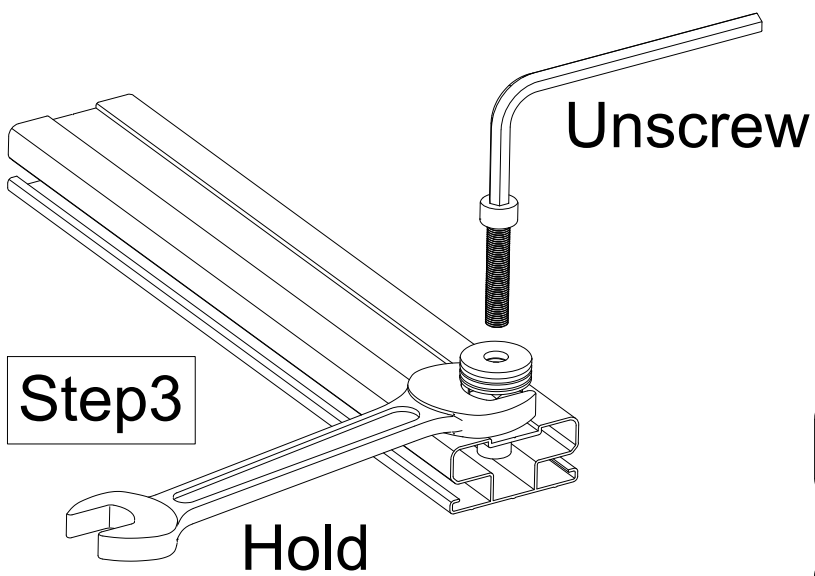

## Contact information

Austria



Belgium



Croatia



Denmark



Estonia



Finland



France



Germany



Ireland



Italy



Latvia



Lithuania



Nederland



Norway



Poland



Portugal



Spain



Sweden



Switzerland



UK

