

For detailed information on assembling the S8 visit:

<https://www.harvst.co.uk/support>

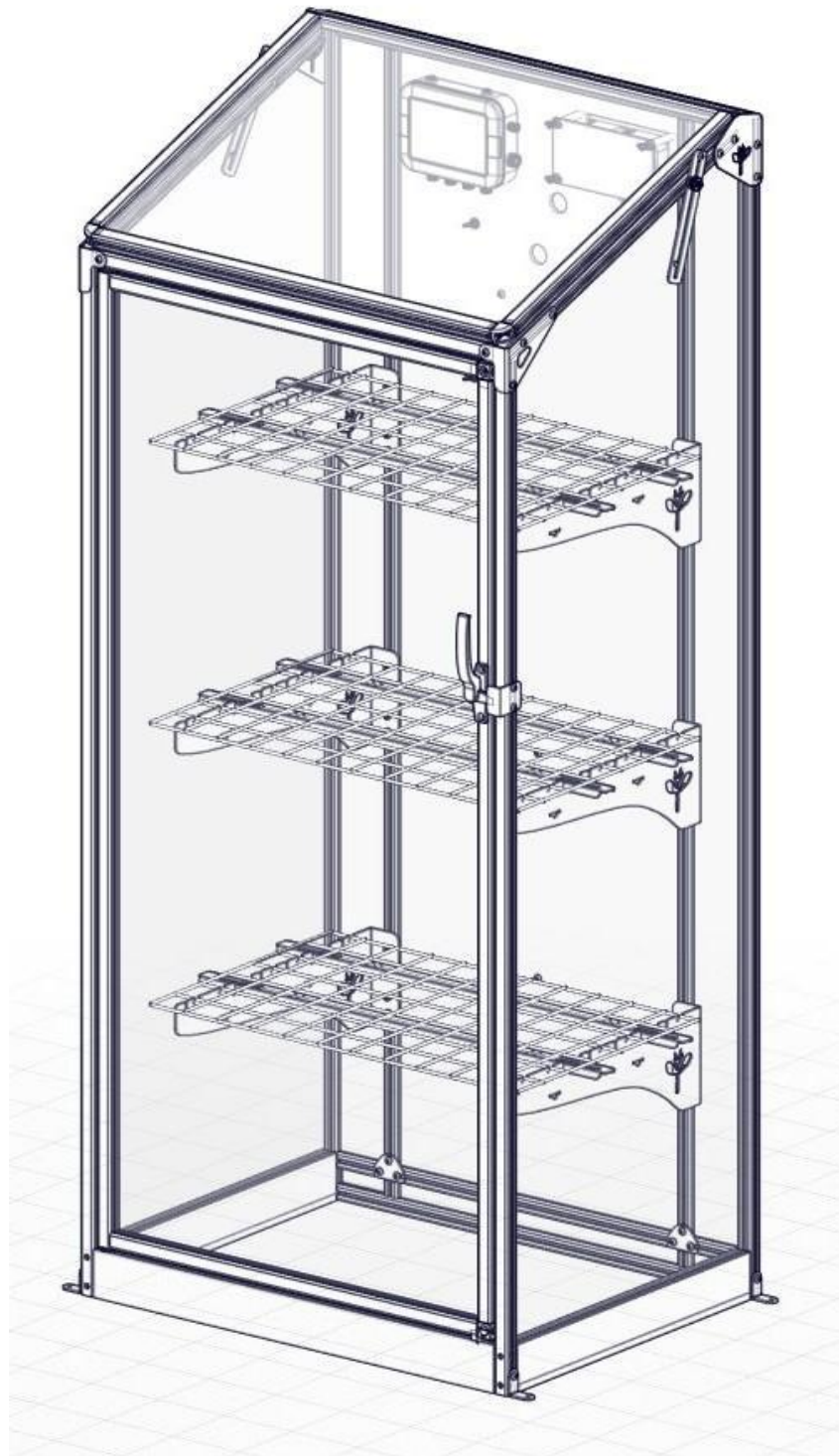

Frame parts

The parts will be labelled with stickers - do not remove these until the part is required.

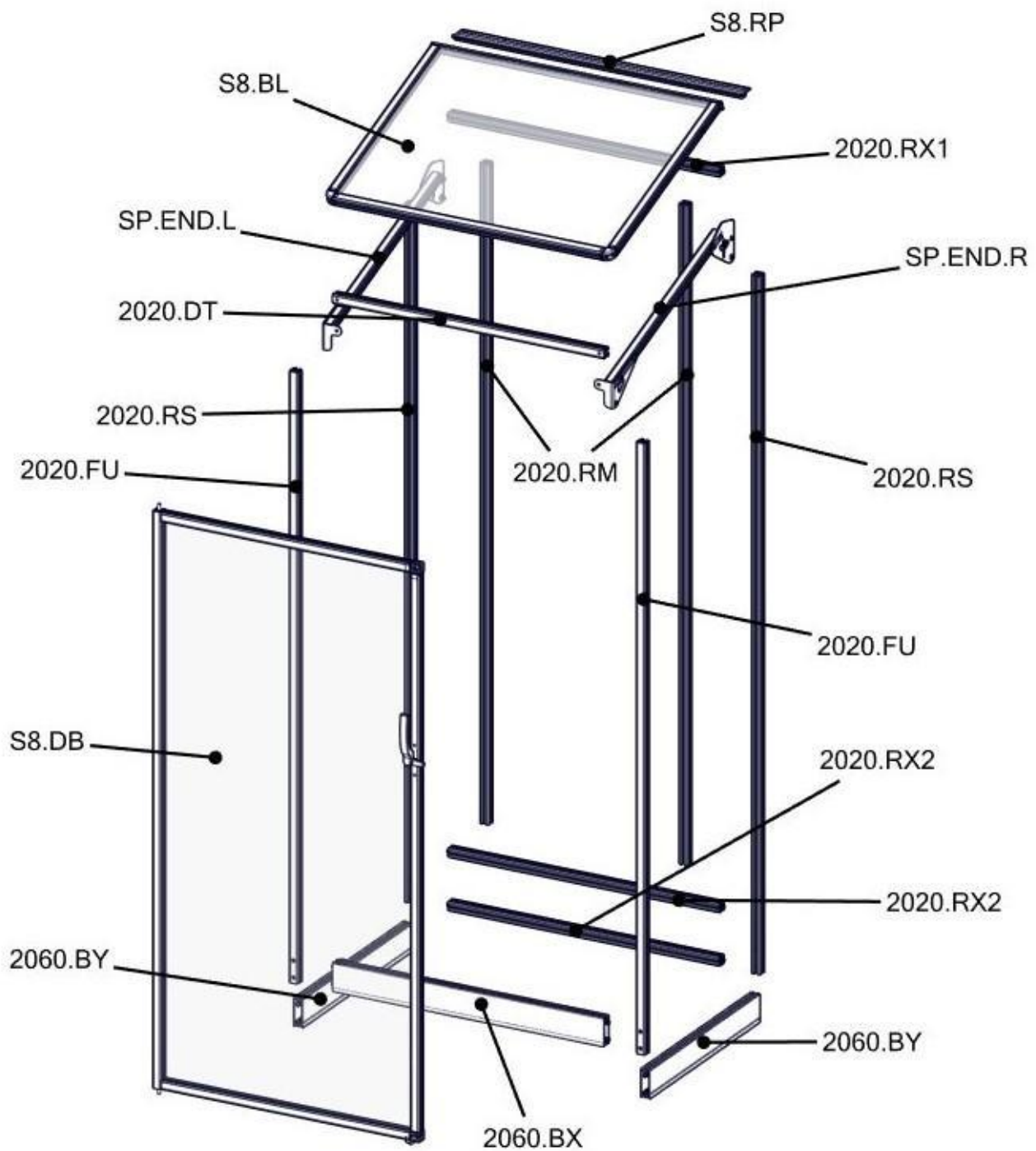





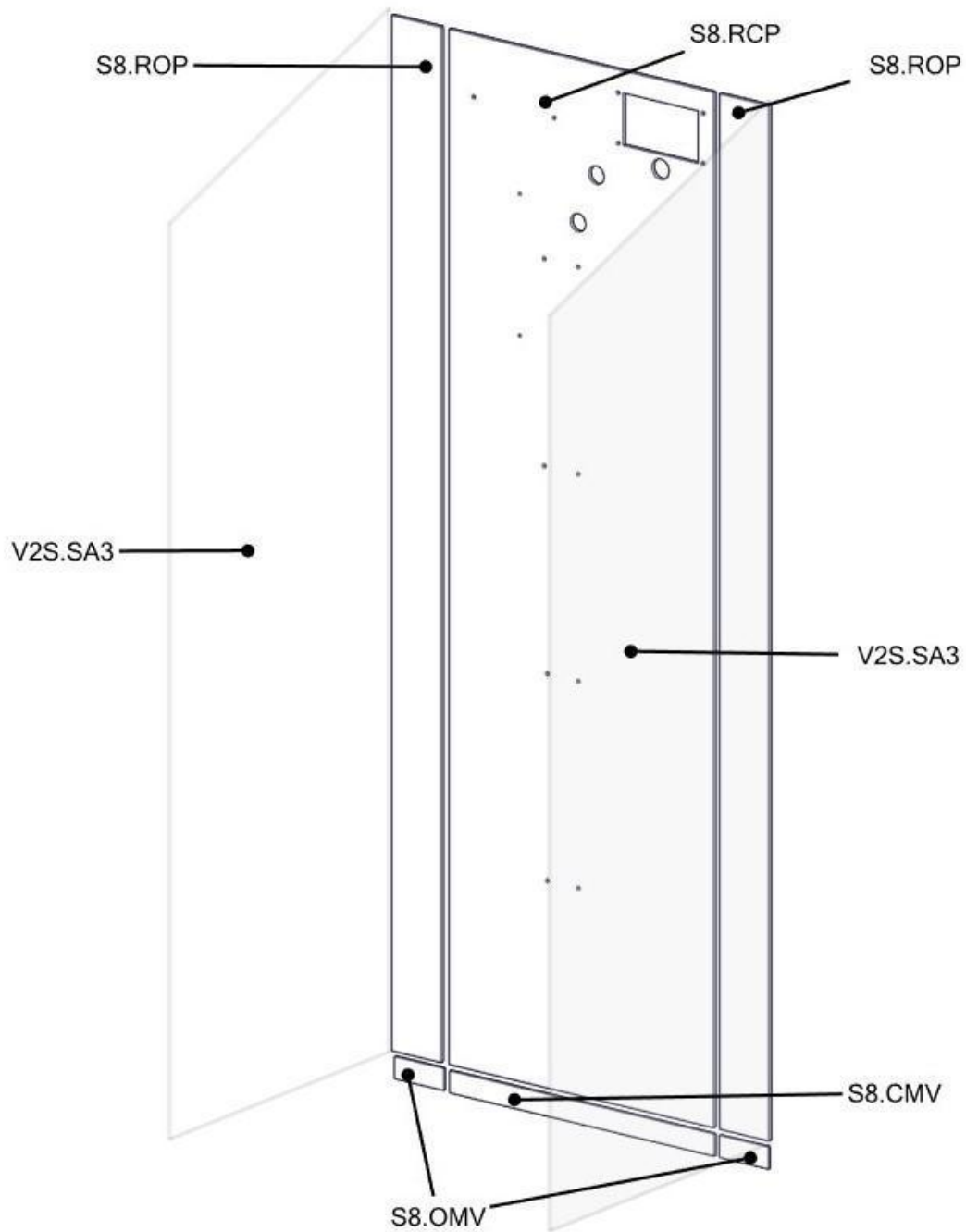





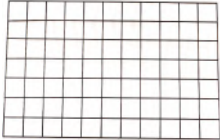

Panels

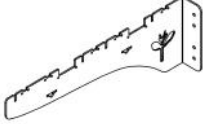
Black panels		Clear panels		Mesh panels	
1x S8.RCP	Rear Centre Panel	2x V2S.SA3	Side panel	1x S8.CMV	Centre Mesh Vent
2x S8.ROP	Rear Outer Panel			2x S8.OMV	Outer Mesh Vent



Components

Image	Name	Image	Name
	1x V2S.SCP Control unit		HOSE.2.5M 2.5m of hose
	1x PSU.200W		3x S8.MS
	1x S8.EXK		3x V2S.SSB.R
	1x SENSOR.TEMP		3x V2S.SSB.L
	1x V2S.HCS Short cable		1x V2S.IRR Irrigation pack
	2x V2S.HCL Long cable		1x V2S.W2SPLIT Cable splitter
	6x LED.SHELF		

Fixings pack



6x
M5X70.C



2x
M5X40.B



4x
M5X30.B



10x
M5X16.B



20x
M5X8.B



24x
M5X8.C



6x 10GX25.PAN
Screw



44x M5.CN
Channel nut



4x M5.N
M5 nut



12x M5.NY.N
Nyloc nut

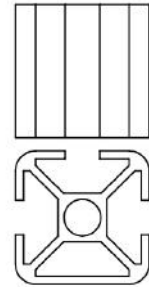

2x 20MM.SP
Spacer



2x M5.RW
Plastic spacer

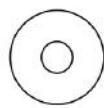

4x M5.PW
Steel washer

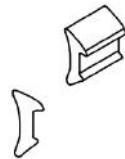

6.5m V2S.GST
Rubber trim

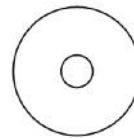

2x S8.DFWH
Plastic washer

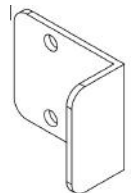

1x S8DCR
Door retainer

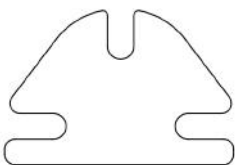

3x ATP
Anti twist plate

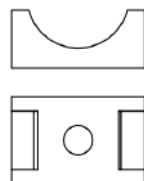

8x CTB
Cable tie base

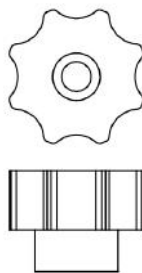

2x M5.PHN
Plastic handle nut

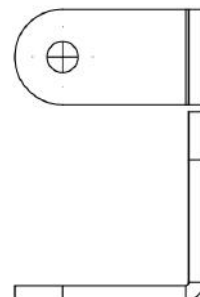

4x SAB.3030
Steel angle bracket

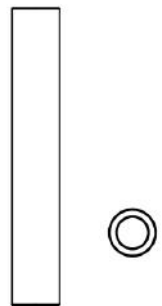

4x 50MM.SO
Plastic stand-off

Other small parts

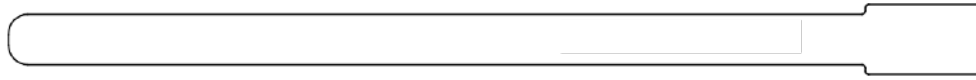

8x RCT Reusable cable tie

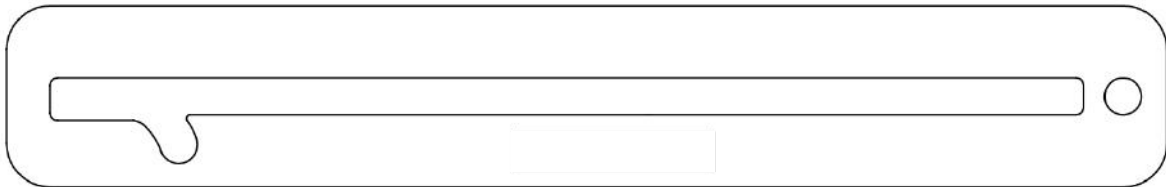

2x V2S.LP Lid prop

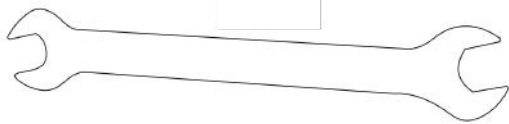

8mm / 10mm spanner



30x 100mm Cable tie



3mm allen key



4mm allen key

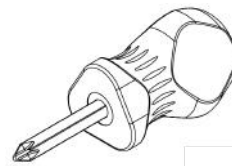

Screwdriver

01 - S8 introduction

Welcome to the assembly guide for your S8 mini greenhouse!

Pre-install checklist

Allocate 2 hrs to the assembly of your S8. Do not remove components from their packaging before completing the step as its labelled on the packing. It can also help to read through the provided parts list and split the fasteners apart to make assembly smoother.

- Mobile phone/ tablet or laptop
- 240V power - waterproof socket. No extension leads.
- Secure fixing area
- Water Source - supply from a clean water source
- Some steps will be easier with an extra pair of hands

2060 and 2020

2060 and 2020 in part names refers to cross sectional dimensions of the aluminium frame component.

20mm x 20mm and 20 x 60mm respectively:

2020

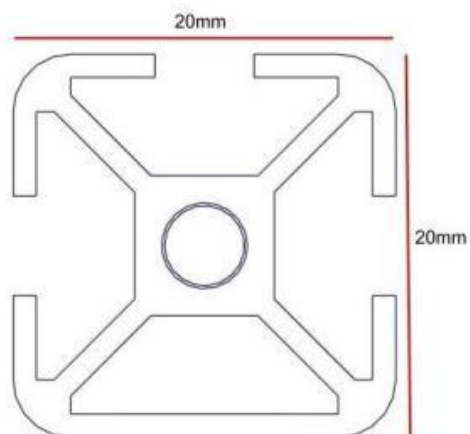

2060

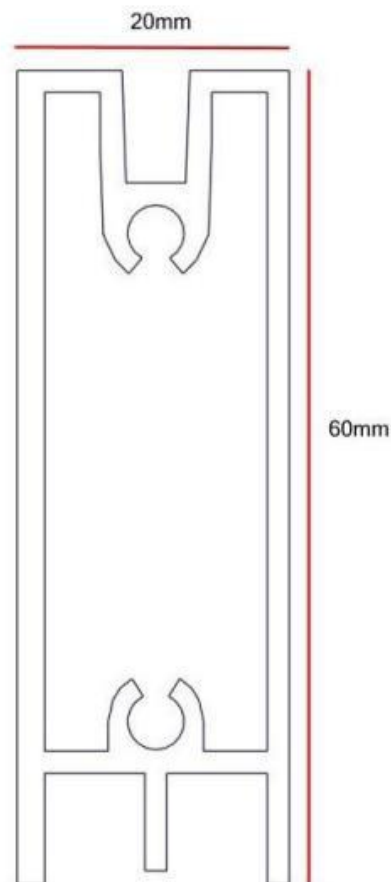

Installing channel nuts

Channel nuts allow components to be fixed to the slot in the side of the 2020 extrusion. The flush face of the channel nut always faces outwards.



Slotting alignment of the screw/ bolt head in channels

The bulk of the frame uses screws or allen head bolts in the channel of 2020 extrusion to secure in place. Take care in locating and threading screws to prevent cross threading and misalignment.

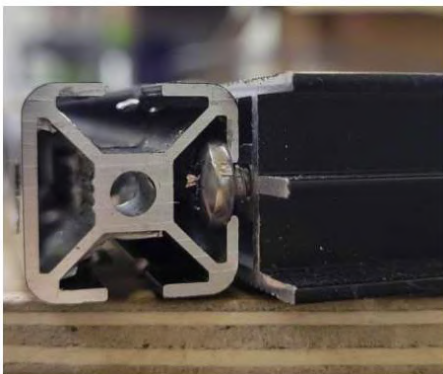

Recommendations for S8 positioning

Like all structures, the longevity and safe operation of the mini greenhouse is only as good as the foundation it is fixed to.

Your S8 needs to be located on a flat, smooth surface measuring at least 700 x 700mm footprint with enough room to open the door fully at the front.

The recommended fixing method is to use the supplied stainless angle brackets and secure all 4 corners to the floor.

For a concrete base you could use rawplugs or we supply 30mm long stainless-steel screws for screwing into a wooden surface.

You may also decide to secure the rear uprights fence panel or posts.

Do not position your S8 directly onto a soft surface such as soil or sand.

02 – Parts

Please see separate parts sheet document / PDF.

03 - Side assemblies

Parts list

- 2 x 2060.BY (45cm, lower side)
- 2 x 2020.RS (rear side upright)
- 2 x 2020.FU (front upright)

Process

1. Place 2060.BY onto the floor/table making sure the single channel is facing upwards.
2. Position 2020.FU with the closed face to the left, opposite the screws (see diagram).
3. Slide 2020.FU over the two pre-installed screws. Tighten through the two holes.
4. Slide 2020.RS onto 2060.BY, with the closed face opposite the screws.
5. Tighten the screws through the holes.

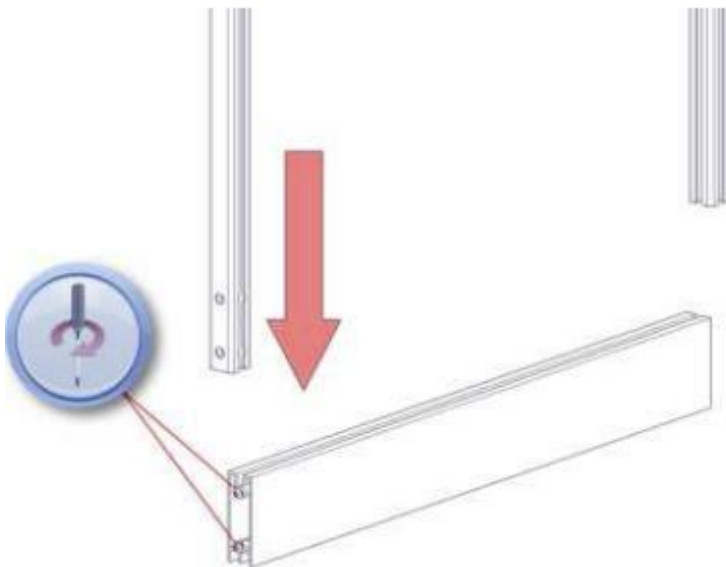

Follow the same steps for the second side assembly.

04 - Rear frame assembly

Parts

- 1 x 2020.RX2 (rear cross bar 2)
- 1 x 2020.RX1 (rear cross bar 1)
- 2 x 2020.RM (rear middle upright)
- 1 x S8.FOAM.VENT.PCK
- 2 x M5x70mm socket head bolt
- 2 x 20mm spacers
- 6 x Channel nuts
- 2 x Anti twist plates
- 6 x M5x8mm button head bolt

Process

We're going to build the bottom part of the rear frame. Refer to the diagram below.

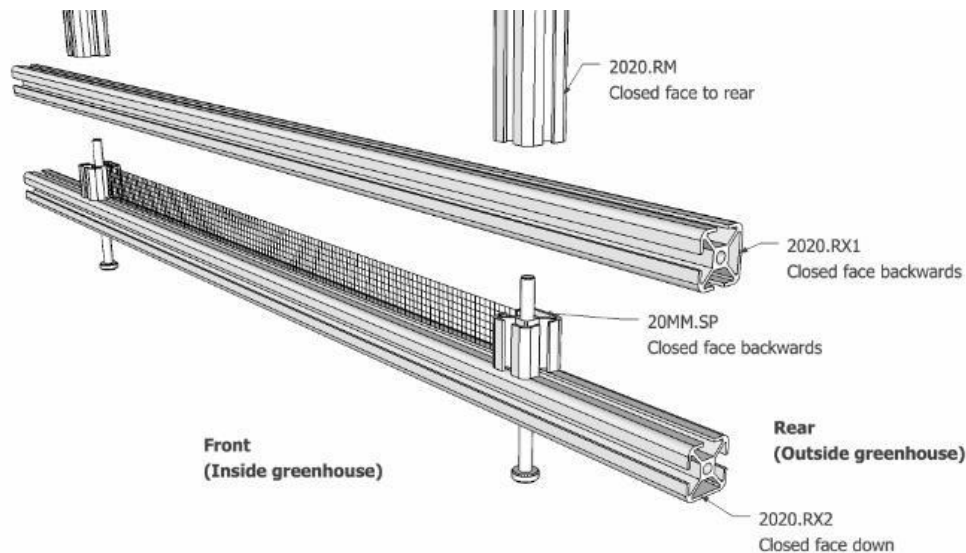

1. Start with 2020.RX2 : position it with the closed face down.
2. Slide two M5x70 bolts through the bottom, the head should seat nicely into the hole provided in the closed face.
3. Slide the 20mm spacers over the exposed ends of the M5x70 bolts. The closed face of the spacers facing away from you.
4. Open the foam vent pack and slide the longer of the three lengths between the 20mm spacers.
5. Slide 2020.RX1 over the exposed M5x70 bolts, with the closed face away from you.
6. Line up the 2020.RM uprights up with the M5x70 bolts. This step is easiest laying the frame flat on a table or flat surface to help with alignment.
7. Closed face of the long 2020.RM to the rear of the greenhouse.
8. Engage the threads carefully, and then tighten the bolts with a 4mm allen key.

Next, we'll fit the anti-twist plates.

1. Slide one channel nut into the front slot of each 2020.RM (upright)
2. Slide four channel nuts into 2020.RX1 (horizontal)
3. Insert M5x8 bolts loosely into the channel nuts.
4. Align the anti twist plates over where 2020.RM and 2020.RX1 meet and fix them in place using M5x8 button head bolts into the channel nuts you have just fitted.

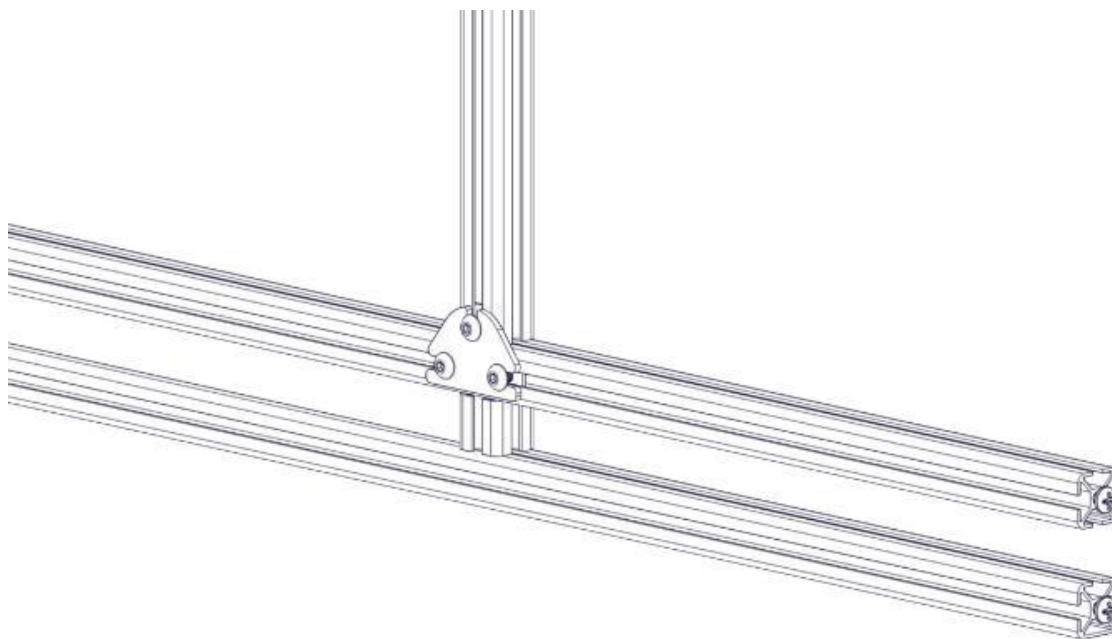
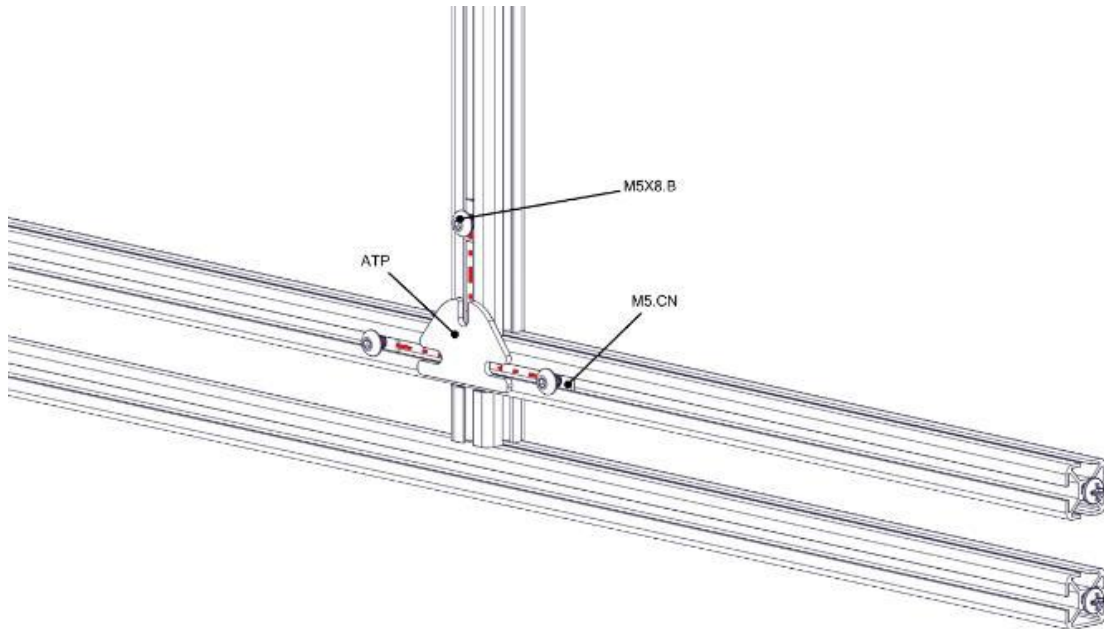

05 - Combine rear frame and side assemblies

Parts

- S8.FOAM.VENT.PCK
- Previous assemblies
- 1 x S8.RCP (rear centre panel; black foam)

Process

Do not do this in a windy location as the rear panel is unsupported at this stage.

1. Slide the small foam panels into the open slots in the bottom left and right corners of your rear panel.
2. Slot the side assemblies you made earlier over screws in the sides of the rear frame from the previous step (see diagram).
3. Tighten with a screwdriver.



Finally, slide the rear panel foam (**S8.RCP**) down between the uprights (**2020.RM**), orientated as shown on the diagram above. Note that the large square hole is at the top right.

06 - Slide S8 frame over front base extrusion

Parts

- 1 x S8 frame so far
- 1 x 2060.BX (base front, 60cm)

Process

1. Place 2060.BX on the floor just in front of the frame, with the single channel facing upwards and the hole on the left hand side.
2. Then slide the front of the s8 over and down onto the two screws on either side.
3. Tighten.



07 - Assemble shelf brackets

Parts

- 3 x Right shelf support brackets (A)
- 3 x Left shelf support brackets (B)
- 24 x M5x8 cap head bolts (C)
- 24 x M5 channel nuts (D)

Process

1. For each bracket you will need four M5x8 and four M5 channel nuts per shelf bracket.

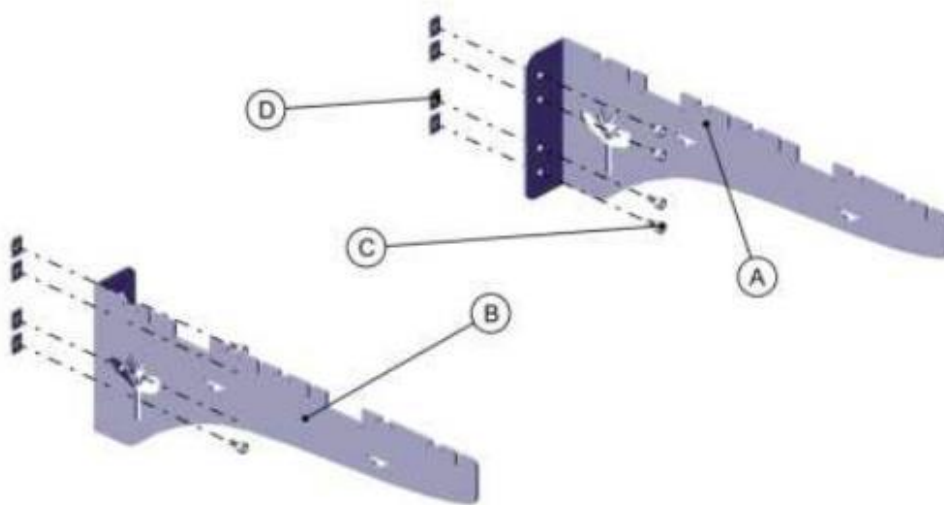

2. Push the bolts through the smaller part of the bracket and fit a channel nut to the back of it.
3. Don't tighten them too much as you will need to slide them into channels later.
4. Follow for the rest of the shelf brackets.



08 - Fit shelf brackets

Parts

- 6 x Shelf bracket assemblies from step 7
- S8 frame

Process

1. Slide the shelf brackets into the front open face of the centre uprights. Note the orientation in the image for left and right brackets.
2. Set the shelves approximately 250mm apart and tighten the bolts with the allen key.

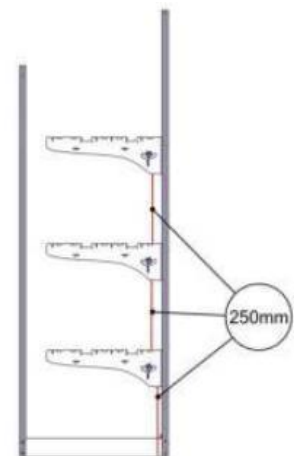

09 - Rear quarter panels and top rear brace

Parts

- 2 x S8.ROP (rear outer panels, black foam) – A
- 1 x 2020.RX1 (rear top bar) – B

Process

1. Slide the two rear outer panels (S8.ROP) into the two open slots in the rear panel making sure they are fully seated into the base by pressing firmly downwards.
2. Slide the top bar (2020.RX1) down over the top of the rear panel, with the closed face at the rear of the greenhouse (matching the rear uprights).
3. Tighten the bolts through the sides of the rear uprights.

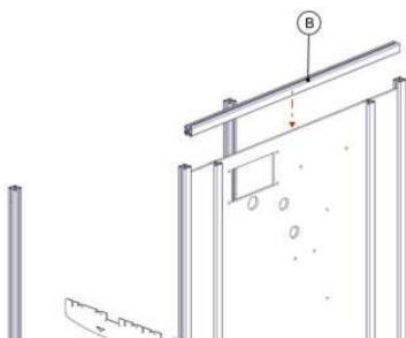

10 - Control unit and power supply

Parts

The fixings for mounting the control unit and power supply are in the control unit packing box.

- 1 x control box
- 1 x power supply
- 1 x air temperature sensor

Mount the control unit

Open the doors on either side of the control unit and push the 16mm bolts through the holes.



Place the control box into the top left of the rear panel of the S8, the bolts will align with the holes in the rear panel. Tighten with an M5 nut and washer on the rear.

Mount the power supply

The power supply sits on the outside rear face of the greenhouse, it is weather sealed so don't worry about the rain. Plug it into an indoors mains plug or an IP67 weather sealed outdoor plug.

Don't use an extension lead.

Use the fixings supplied with the control unit.

From the outside, push one M4x16 bolt (M4.16.C) through the lower hole marked in the attached diagram and fit one M4 penny washer (M4.PW) and one M4 wing nut (M4.WN) to the inside.

The diagram below is from the inside of the greenhouse, as though the rear panel was see-through.

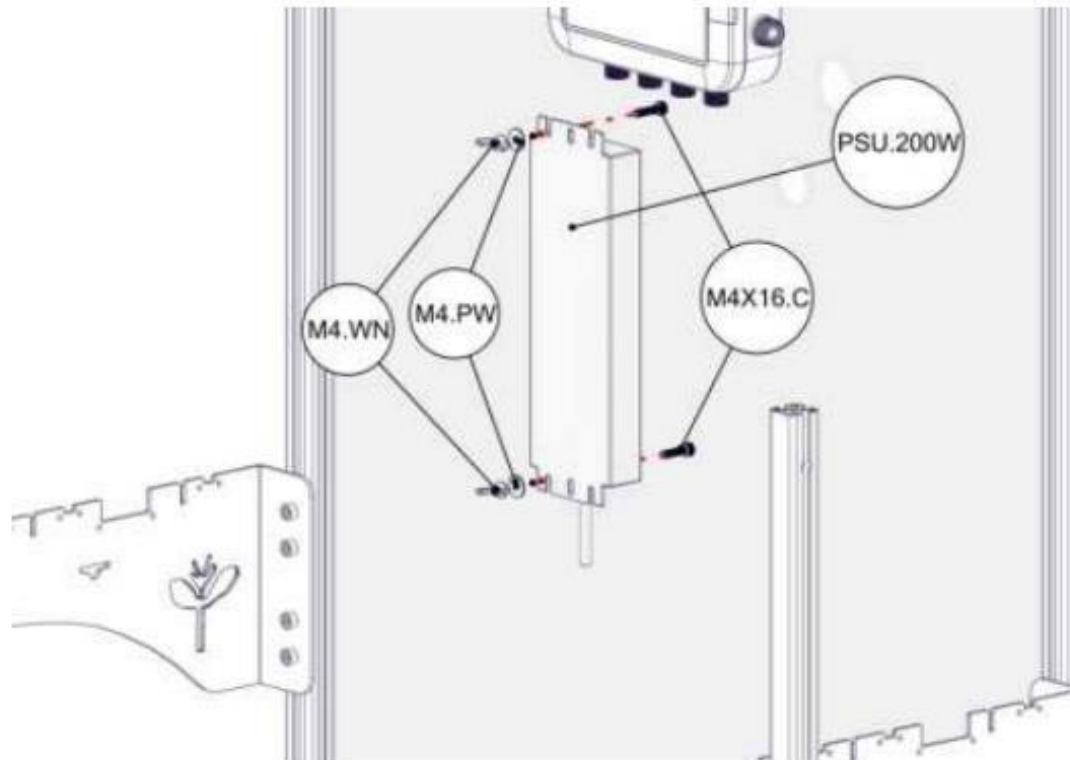

Slide the power supply down onto the bolt you have just fitted using the notches in the top and bottom of the casing, the end with the UK plug is facing down towards the ground.

Push another M4X16 bolt through the top hole and notch of the power supply then fit another M4 washer and M4 wing nut to the inside.

Tighten both wing nuts to securely fix the power supply in place.

Connect the air temperature sensor

Plug the air temperature sensor into the top right port of the control unit labelled 'Temp'.

11 - Light cables and supports

Parts

- 8 x cable tie base
- 8 x M5x16mm button head bolts
- 8 x M5 nyloc nuts 1 x light splitter cable
- 4 x reusable cable ties

Process

- Fit the cable tie bases to the interior of the S8 with the 16mm bolts, there are two sets of holes that run parallel down the back panel. Tighten them in place with a nut on the rear.



The left hand supports are for the light cable, and the right hand supports are for the irrigation pipe.

Install light splitter cable

Plug in the light splitter cable to the right-hand side port of the control unit labelled '4' and run it down the left-hand side cable tie bases.

Secure with 4x reusable cable ties

12 - Extractor fan

Parts

- Extractor kit (in box)
- 4x M5x70mm bolt
- 4x 50mm standoff (50MM.SO)
- 4x M5 nut

Process

Be careful with the extractor unit while it is being handled. Do not pull the wires.

- Push the black cover panel through the hole from the rear then push the extractor into place, the open end pointing downwards.
- Push the four long bolts through from the rear.



- Put the sections of pipe (50MM.SO) over the open end of the bolt then place the cover plate on top.



- Secure into place with the M5 nuts.



- Connect the short wire to the top left hand side port of the control unit labelled 'fans'.

13 - Heater cables

Parts

- 2 x long heater cable
- 1 x short heater cable

Process

Install the heater cable into the upright slots of the shelf supports. They run back and forth under the shelf to gently warm any seed trays or pots you have above.

- There is one heater cable per shelf, you're supplied with two long ones and one short one. The short ones are for the top shelf and the long ones are for two lower shelves.
- Run them through the slots in the shelf supports starting from the front.
- Plug the heater cables into the three left control unit connectors on the box, labelled '1,2,3'.

Tip: The cables are easier to install when warm. You can configure your control unit to turn on the heaters above zero degrees, which will turn on all heater ports.

14 - LED grow lights

Parts

- 6x LED light
- 3x Mesh panel
- 20 x 100mm Cable tie

Install LED lights

- Place the LED lights into the slots in the shelf support brackets, LED facing down, cables to the left.
- Plug the Led lighters into the splitter cable.
- Cable tie the lights to the shelf supports as shown in the photo below.

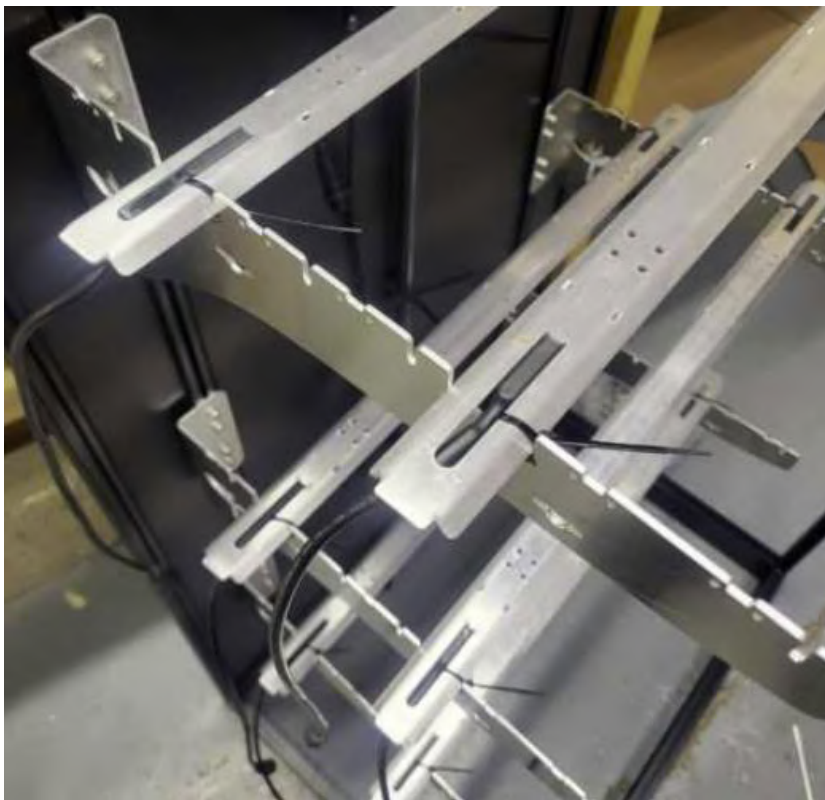

Install mesh shelves

- Fit the mesh shelves into the slots on the support brackets.
- Cable tie them into place with the holes provided.

15 - Irrigation / watering

Parts

From the irrigation components pack:

- 13mm end plug
- 13mm elbow
- Filter
- Pump
- LDPE pipe is the stiffer, smoother pipe.
- Braided hose is like a garden hose.

Process

- Open the irrigation components pack.
- Fit the end plug to one end of the LDPE pipe and the elbow to the other. (this can be made easier by warming the pipe in some hot water).
- Fit the LDPE pipe to the right hand set of cable tie bases.
- The elbow goes at the top through the hole directly above the cable tie base.
- Lock the pipe in place with the reusable cable ties.
- Attach the braided hose to the open end of the elbow from the outside of the greenhouse.
- Attach orange pump to open end of braided hose and plug the connector into the control unit.
- Cut the braided hose halfway down and fit the inline filter, note the arrow with direction of flow (arrow faces away from pump).

Water distribution

Use the remaining irrigation parts to distribute water around the greenhouse - the exact method will depend on what you are growing.

Punch holes in the LDPE pipe with the supplied punch, fit joiners, and then 4mm hose to either drippers or sprayers.

Sprayers can be secured to the shelves, drippers are best placed into pots or watering trays.

The pump can be set to run for X seconds every Y hours; a good starting point is:

- 20 seconds every 24 hours in winter
- 30 seconds every 12 hours in summer

Water source

Place the pump into a suitable water tank. If your water source is further away than the supplied hose will allow, you can add standard garden hose to extend it. Bear in mind that the available pressure and flow at the drippers / sprayers will reduce if your tank is further away.

If you move the pump, you will probably also need a pump extension cable; these are available in our online shop.

16 - Clear side panels

Parts

- 2 x V2S.SA3 - Side glazing panels.
- 6.5m - V2S.GST - Rubber glazing trim.

Process

Remove the protective film from both sides of the perimeter of the side glazing panels.

Slide the clear side panels into the open slots of the side assemblies, the angled side matches the front and back uprights (see image).

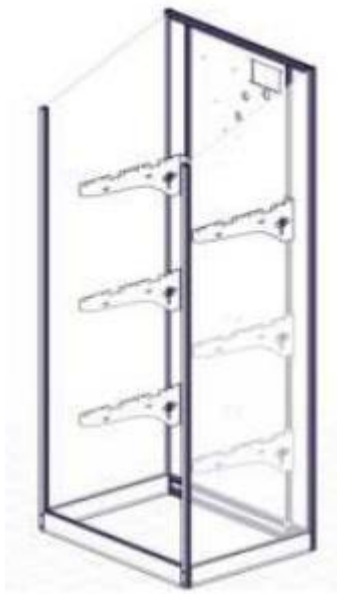

Fit the glazing rubber trim to the upright edges as outlined in red below. The narrow short edge, outlined in green, slots between the glazing surface and the outer edge of the frame channel. Start at one end and work the seal edge in ensuring the seal trim isn't bunched up. Use some sharp scissors to cut the length required.

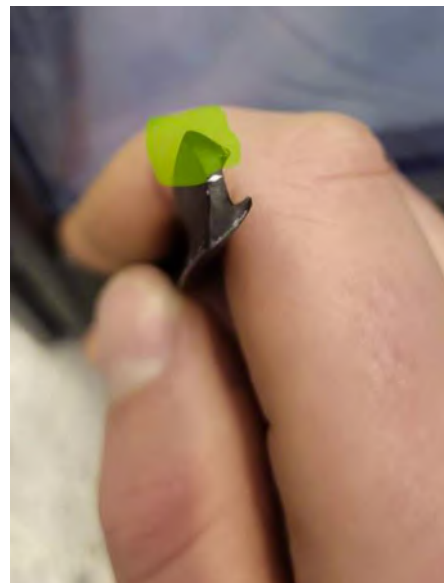

17 - Prepare top side assemblies

Parts

- 1 x SP.END.L
- 1 x SP.END.R
- 6 x M5x8 button head bolts
- 6 x M5 channel nuts
- 2 x M5x40 button head bolts
- 2 x M5 Nyloc nuts

Process

1. Slot two M5x8 bolts through the spare holes of the flat plate, in the direction shown in the drawing below.
2. Loosely fit a channel nut to each bolt on the inside.
3. Slide one M5x8 bolt through the outside face of the bent bracket.
4. Loosely fit a channel nut to the inside.
5. Repeat for other assembly.

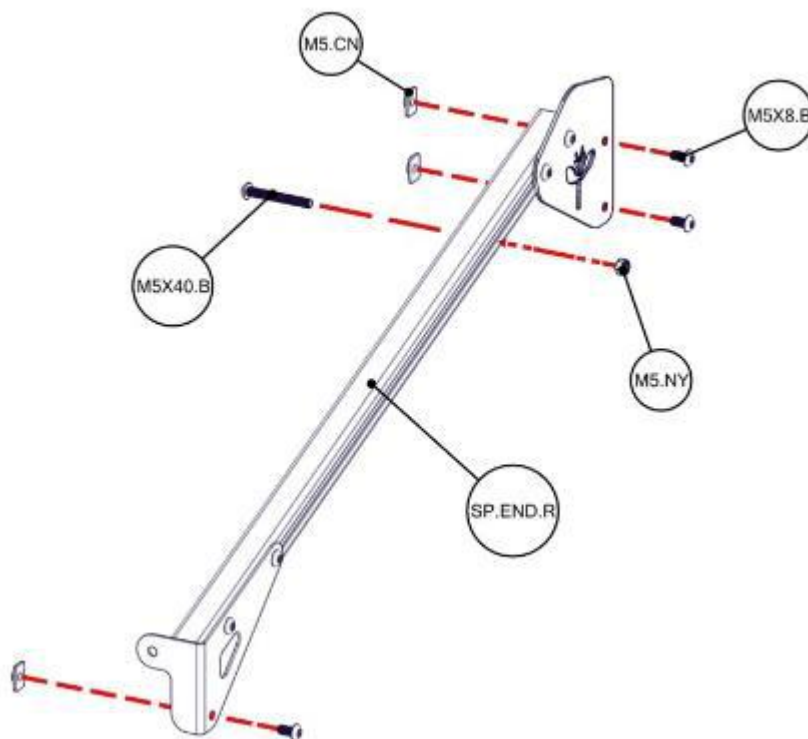

18 - Install top side assemblies

Parts

- Built up top side assemblies
- S8 Frame

Process

Starting with the right-hand side assembly, slide it into the frame.

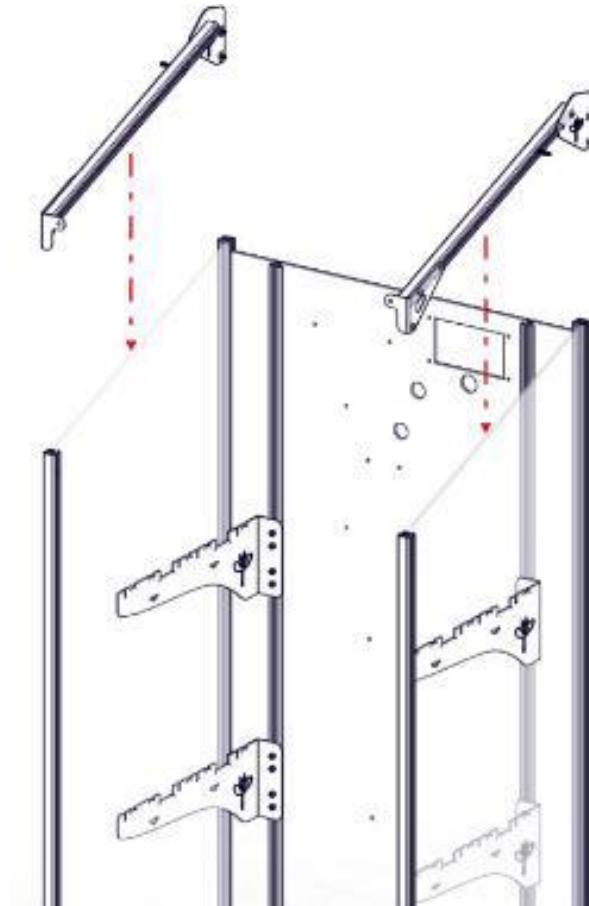

Repeat for left hand side.

Tighten.

19 - Install the door seal trim and door

Parts

- 1 x S8 door
- 1 x 2020.DT (door top bar)
- 2 x M5X30mm bolt
- 2 x S8.DFHW (door washer)
- 2 x M5.PW (M5 penny washer)
- 2 x M5 nyloc nut
- 4 x M5x8.B
- 4 x M5.CN
- 1 x S8.DCR (door retainer)
- 3.0m BST (bubble seal trim)
- 1 x ATP (anti twist plate)

Process

Assemble door top bar

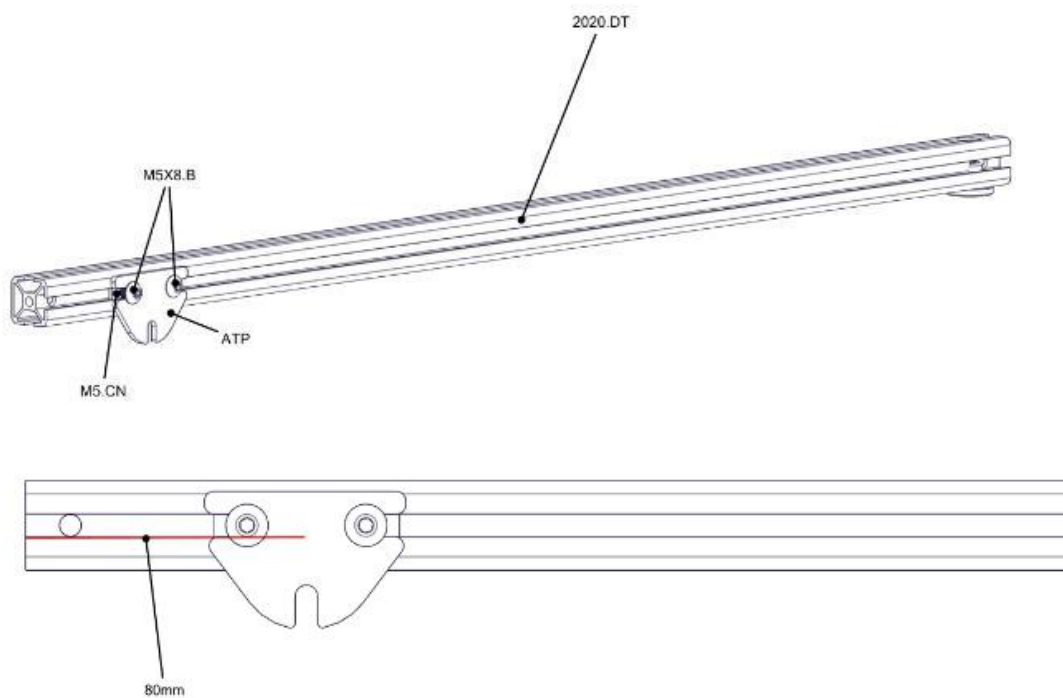

Door seal trim

The bubble seal trim has a rigid base that slots into the open channel of the extrusion. This can be slotted in through the ends or pushed in with some pressure. The trim is orientated with the leg facing inwards as seen below. Use some sharp scissors to cut the seal trim to length.

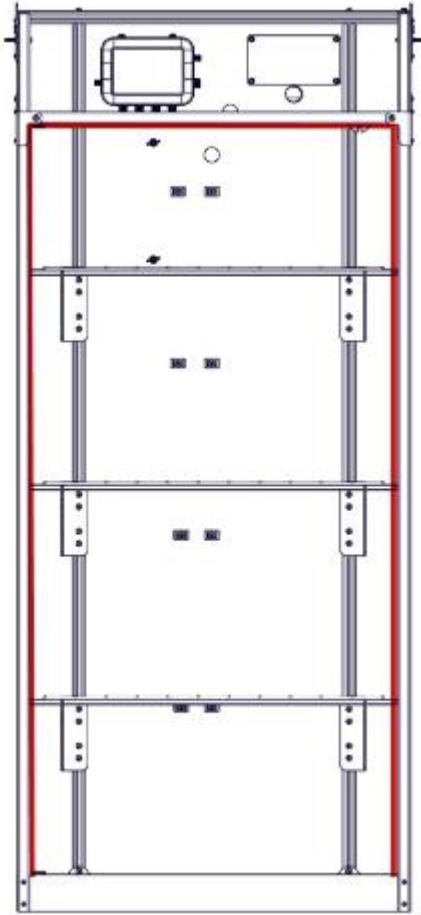

Door catch retainer

Assemble the door catch retainer as shown in the diagram below. Do not fully tighten the bolts and channel nuts.

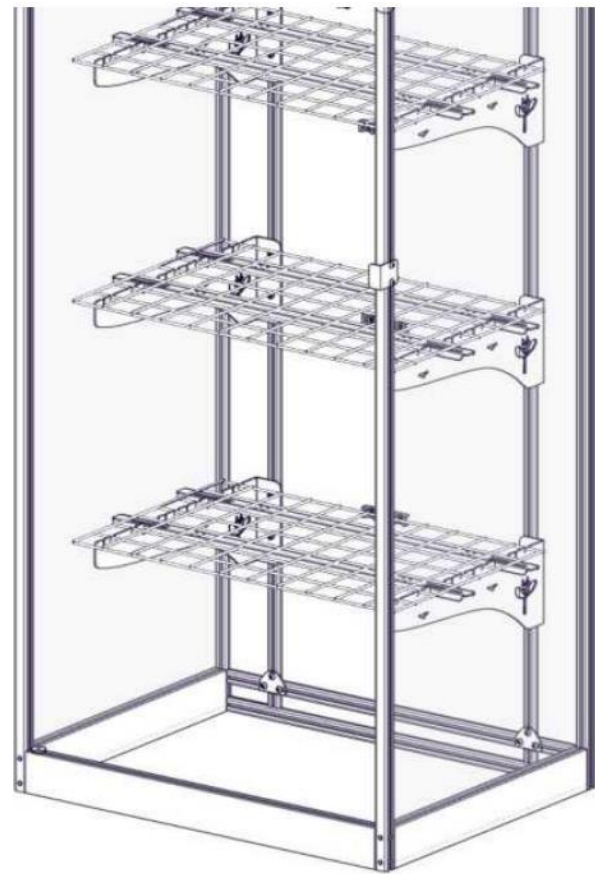
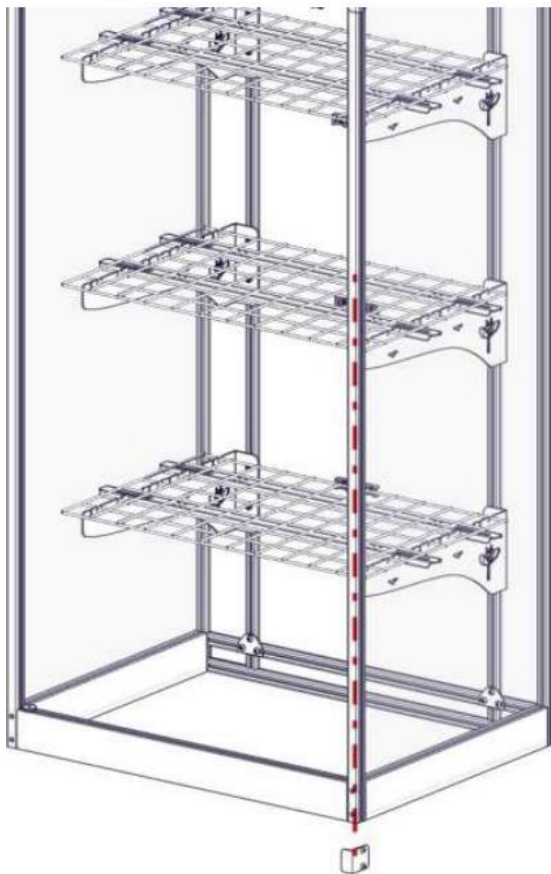
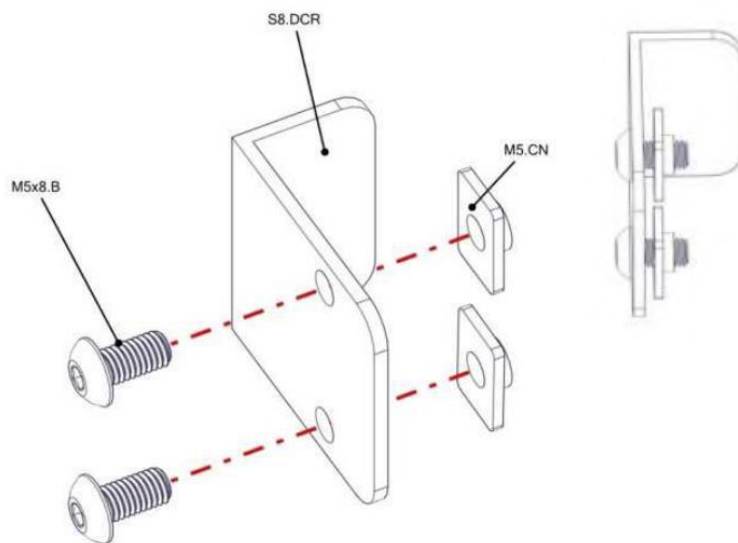

The door slots into a hole on the underside of the top door bar and a hole in the front base you fitted earlier. To fit it you will slot the door into the base extrusion then slide the top door bar over it and bolt it in place.

1. Fit one plastic door washer (S8.DFWH) to the bottom hinge pin of the door assembly. Slot the door into the base extrusion.



2. Place another plastic washer on the stud at the top of the door.
3. Fit the assembled top door bar (2020.DT) into place.
4. Thread the 30mm bolts through the holes in the corner brackets. The head of the bolt is facing towards you.
5. Tighten with an M5 washer and nyloc nut on the rear.



20 - Fit the lid

Parts

- Built Lid
- 1x V2S.RIDGE (ridge part)
- 2 x M5x30mm bolts
- 2 x M5x10mm bolts
- 2 x M5 Spacer
- 2 x M5x16 mm bolts

Process

1. Slot the ridge part into the lid.
2. Place the lid over the S8 frame, the hinging side goes at the rear.
3. Fix down into the outside rear uprights using M5x16 Bolts
4. Fix down to centre uprights using M5 x 30 bolts.
5. Attach the upper end of the lid prop using the M5x10 bolts and M5xSpacer (the spacer is between the lid prop and frame)

21 - Install lid prop

Parts

- 2 x V2S.LP (lid prop)
- 2 x M5X16.B (16mm bolts)
- 2 x M5.RW (plastic spacers)
- 2 x M5.PW (penny washer)
- 2 x M5.PHN (plastic handle nuts)

Process

Both sides of the lid have a prop, which is used to hold the lid open, and also hold the lid closed when the plastic handle nut (M5.PHN) is screwed tight.

The lid already has channel nuts fitted.

Start by securing the top of the prop with a 16mm bolt, and a plastic spacer between the prop and the lid. Make sure the slot of the prop goes over the stud you fitted to the top side assembly.

Add the penny washer and handle nut as shown below.

Don't tighten yet.

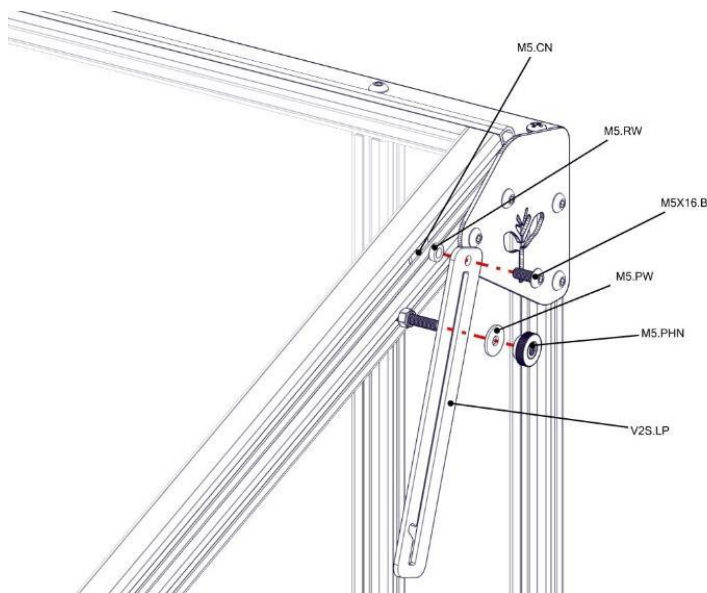

Slide the channel nut down so the top of the prop is 100mm (10cm / 4") from the rear of the lid, as shown below:

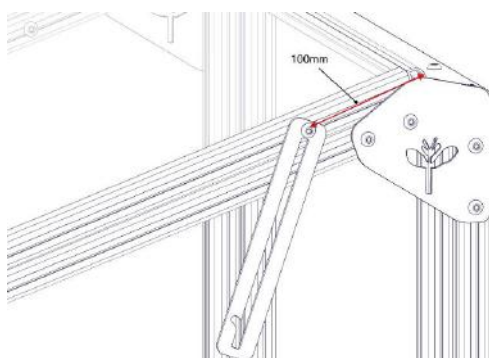

Tighten the 16mm bolt so that the channel nut locks into the channel.

Repeat for the other side.

22 - Fit securing brackets

Parts

- 4 x SAB.3030 (angle brackets)
- 4 x M5X8.B (8mm button head bolts)
- 4 x M5.CN (channel nuts)
- 4 x 10GX25.PAN (screws)

Process

Ensure your greenhouse is located on a flat rigid surface with good access to power and sunlight.

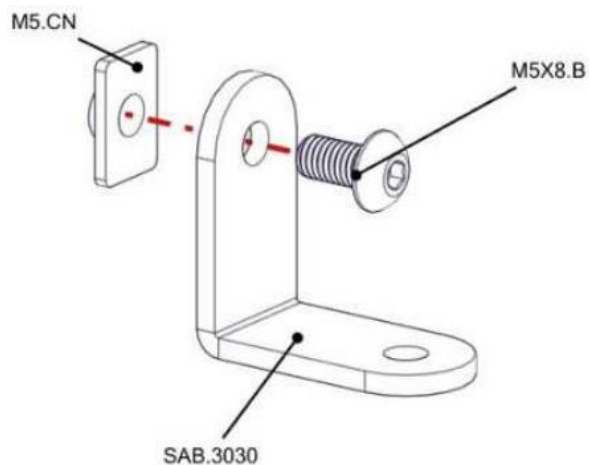

1. Prepare your securing brackets as in the diagram.
2. Slot the securing bracket assemblies into the channel of the outer uprights on all 4 corners
3. Ensure the bottom face is flush with the floor and secure in place using the 3mm allen key.

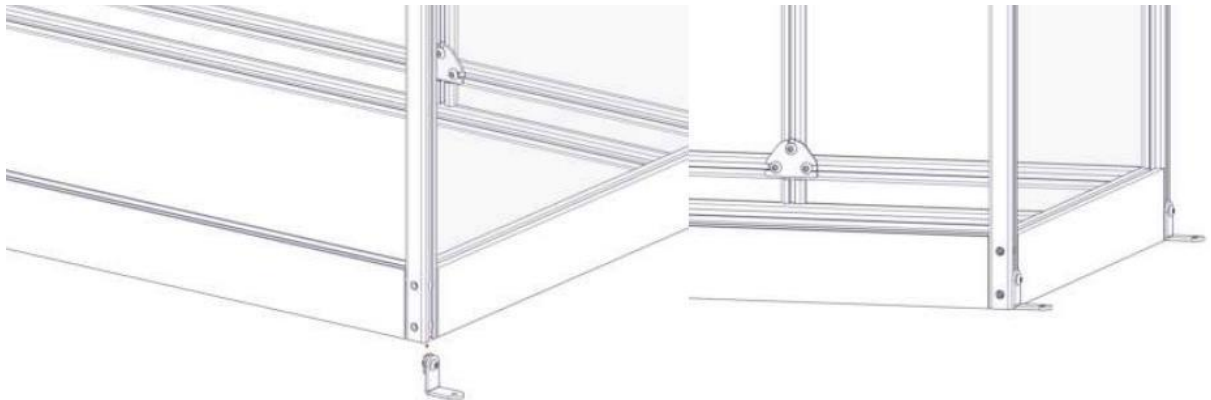

The four brackets can also be used on the rear of the greenhouse to secure it to a fence or wall.

Congratulations! Your greenhouse is now complete.