

MODULARO®

WOOD SHED TORVIK

2,5x2,5x2,45m



16-03-2026

Art. Nr. WC165440

1/14

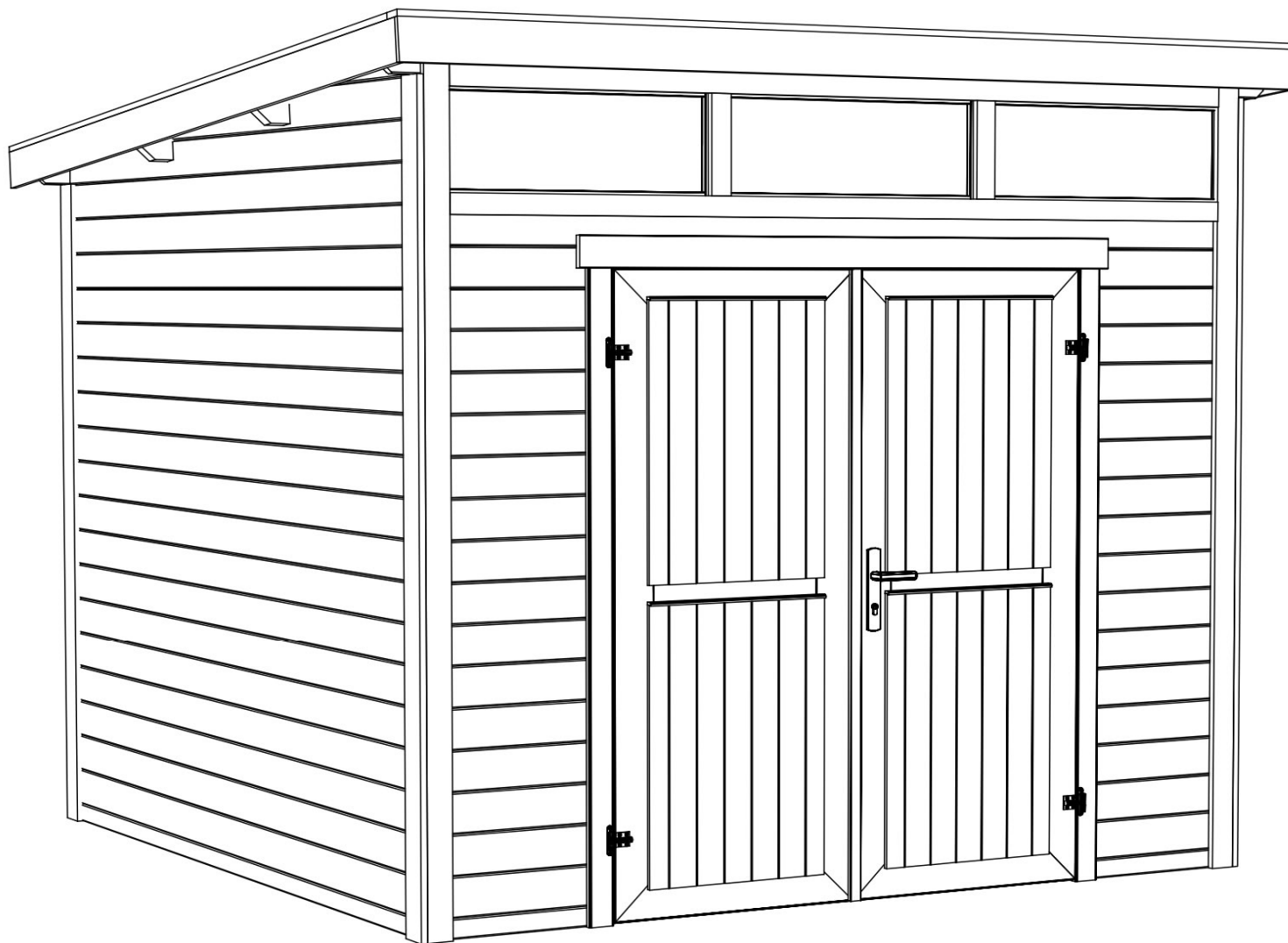





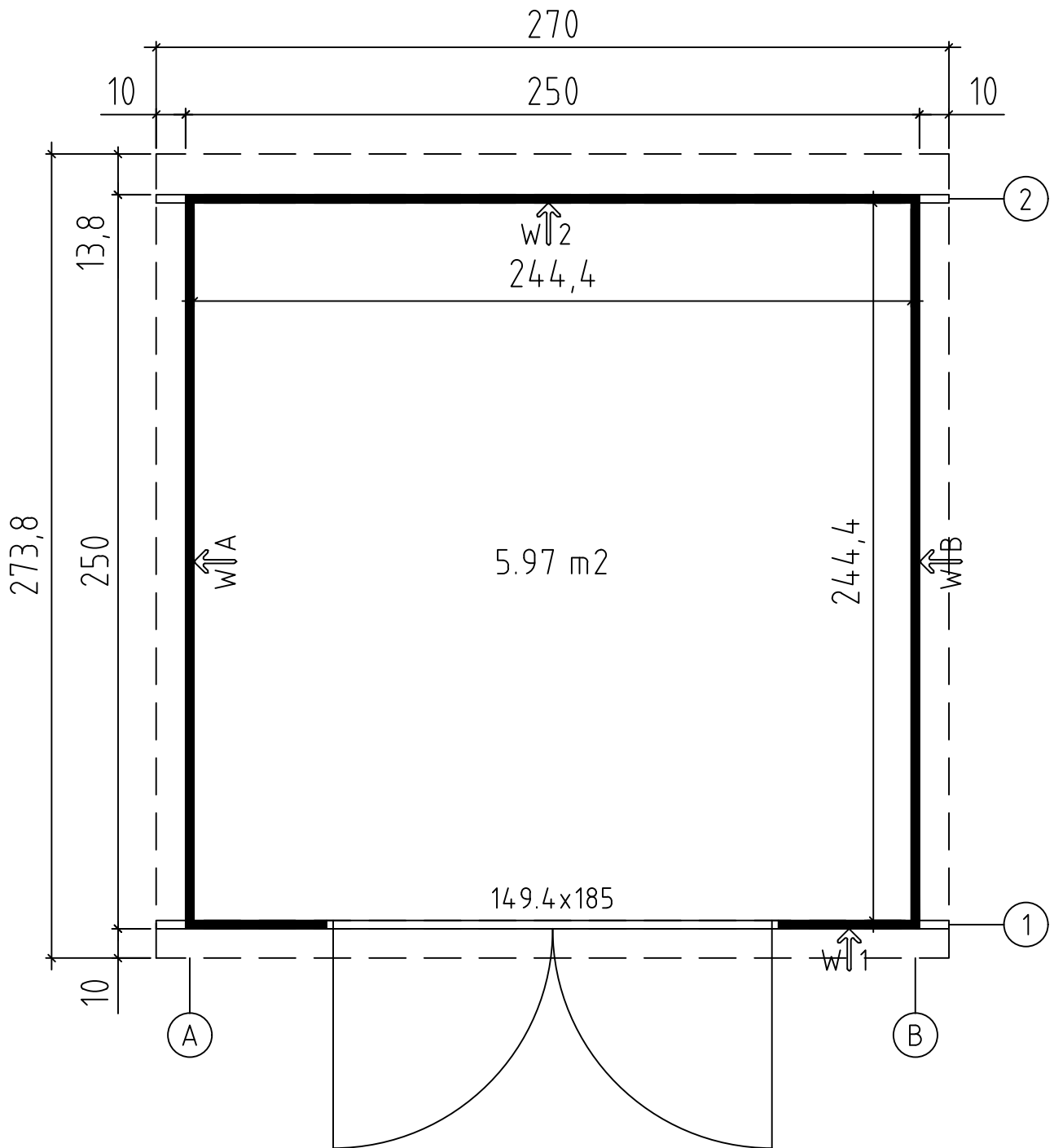



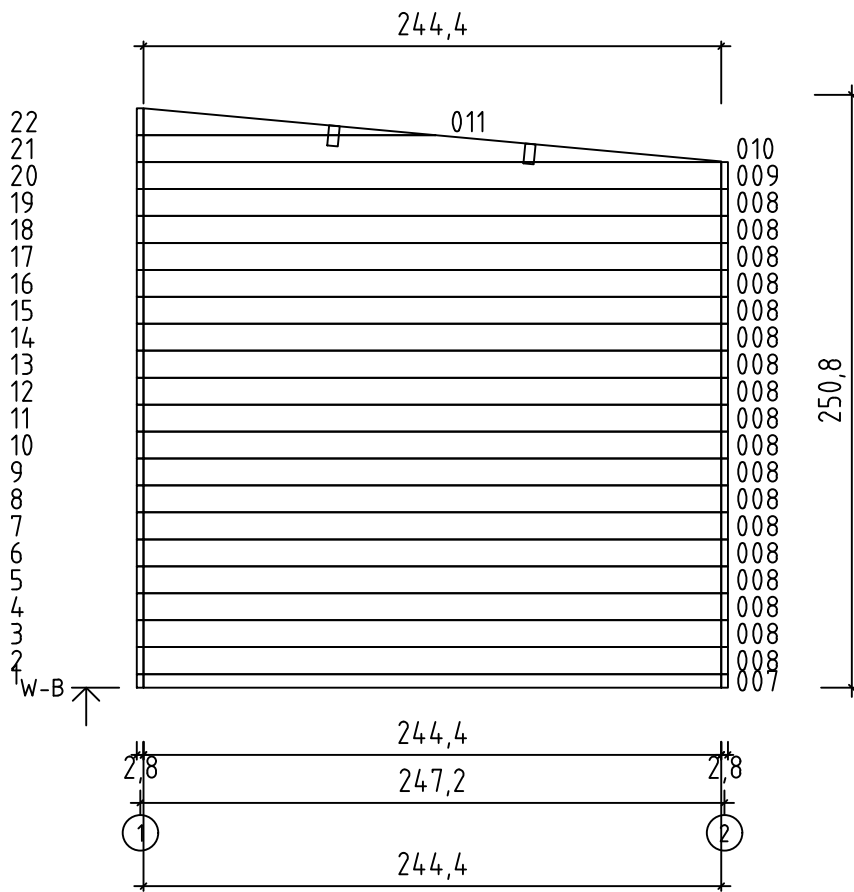
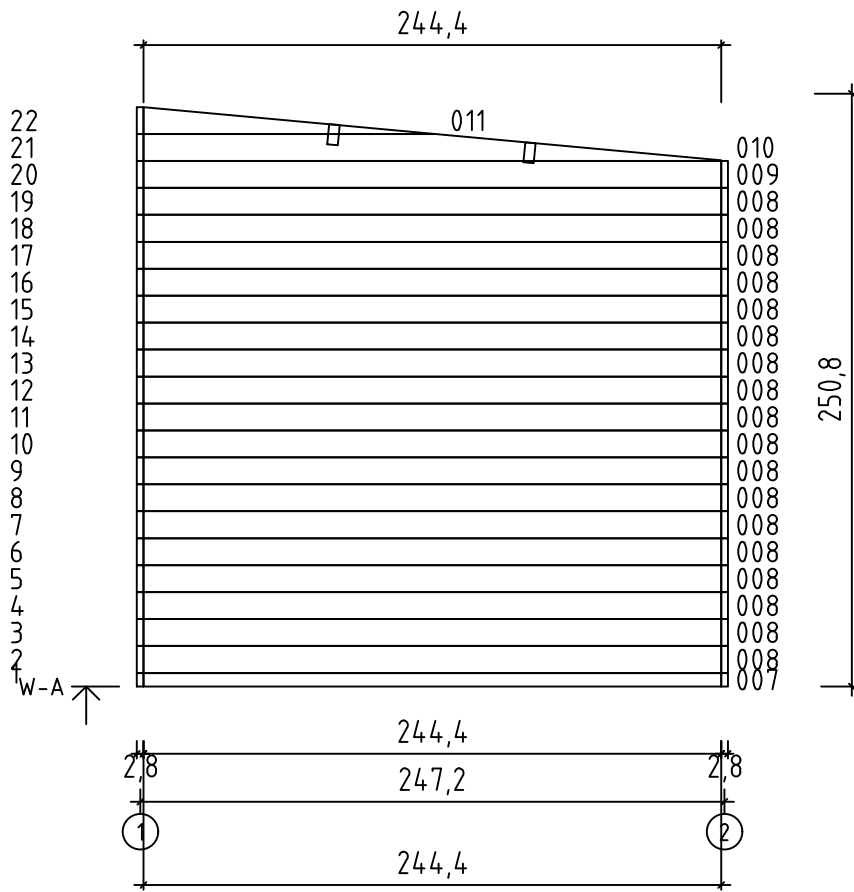







23.04.2024

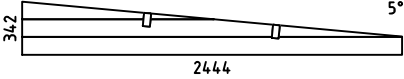
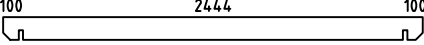
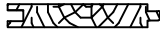

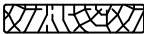

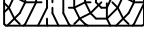

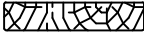



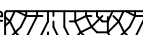
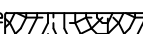
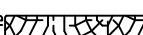
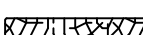
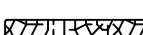
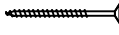

Groundplan - Grundplan - Plan de masse - Planimetria
- Plattegrond - Planimetría - Põhiplaan

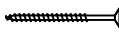

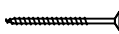
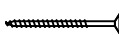
Art. №. 2851496

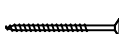

Pos	23.04.2024 Piece list - Stückliste - Liste des pièces - Elementi - Stuklijst - Elementos - Tükítabel Art. Nr. 2851496	5/14	Q	P (mm)	L (mm)
001 40029			2	28x57	480
002 40030			32	28x114	480
003 43025			1	28x114	2500
004 40031			2	28x114	2700
005 37551			1	28x57	2500
006 6141			18	28x114	2500
007 23526			2	28x57	2444
008 953			36	28x114	2444
WA-1 WB-1 23527			1 1		
A-PR1 40041	Roof beam - Dachbalken - Panne de toit - Perlina del tetto - Gordingen / dakbalk - Correa - Pärllin 		2	44x146	2700
DB 19015	Roof boards - Dachbretter - Voliges - Perlina per tetto - Dakhout - Tablero de tejado - Katuselaud 		30	90x15.5	2750
RFF1 40850	Roofing felt fillet - Dachpappenleiste - Baguette de fixation du feutre bitumeux - Asse per fissaggio guaina bituminosa - Afdeklijst asfaltpapier - Moldura de fieltro para tejado - Katusepapiiist 		1	18x58	2736
RFF2 22612	Roofing felt fillet - Dachpappenleiste - Baguette de fixation du feutre bitumeux - Asse per fissaggio guaina bituminosa - Afdeklijst asfaltpapier - Moldura de fieltro para tejado - Katusepapiiist 		2	18x58	2760
CF1 43028	Corner fillet - Deckleiste - Profils de finition angles a l'exterieur - Massello d'angolo - (hoek)lijst - Moldura de esquina - Nurgaliist 		2	18x70	2220
CF2 24882	Corner fillet - Deckleiste - Profils de finition angles a l'exterieur - Massello d'angolo - (hoek)lijst - Moldura de esquina - Nurgaliist 		2	18x70	2451
CF3 43029	Corner fillet - Deckleiste - Profils de finition angles a l'exterieur - Massello d'angolo - (hoek)lijst - Moldura de esquina - Nurgaliist 		2	18x90	2109
CF4 24886	Corner fillet - Deckleiste - Profils de finition angles a l'exterieur - Massello d'angolo - (hoek)lijst - Moldura de esquina - Nurgaliist 		2	18x90	2337
P1 48038	Post - Pfosten - Poteau - Piede registrabile - Stijl - Poste - Post 		2	55x55	2203
P2 48039	Post - Pfosten - Poteau - Piede registrabile - Stijl - Poste - Post 		2	55x55	2430
TB 15113	Fascia board - Traufbrett - Bandeau de toit - Finitura lati tetto - Gevelliist - Tablero de alero - Räästalaud 		1	18x58	2700
DRV 1817	Roof edge reinforcement - Dachrandverstärkung - Corniere de renfort de bord de toit - Rinforzo x tetto - Dakrand versterking - Refuerzo de aleros - Räästafugevdus 		1	28x34	2700

Pos	Piece list - Stückliste - Liste des pièces - Elementi - Stuklijst - Elementos - Tükítabel 23.04.2024 Art. Nr. 2851496	6/14	Q	P (mm)	L (mm)
FF 23522	Fixing fillet - Fixierungsleiste - Profil de fixation - Massello di fissaggio - Bevestiging lijstwerk - Moldura en T - Tenderlijst		2	18x28	1850
RS1 43026	Batten - Deckleiste - Profils de finition angles a l'exterieur - Asse - Afdek lijst - Moldura de recubrimiento - Tuulelaud		4	18x58	284
RS2 48541	Batten - Deckleiste - Profils de finition angles a l'exterieur - Asse - Afdek lijst - Moldura de recubrimiento - Tuulelaud		1	18x58	2330
RS3 12818	Batten - Deckleiste - Profils de finition angles a l'exterieur - Asse - Afdek lijst - Moldura de recubrimiento - Tuulelaud		1	18x58	2360
RS4 48542	Batten - Deckleiste - Profils de finition angles a l'exterieur - Asse - Afdek lijst - Moldura de recubrimiento - Tuulelaud		1	18x90	2330
RS5 48543	Batten - Deckleiste - Profils de finition angles a l'exterieur - Asse - Afdek lijst - Moldura de recubrimiento - Tuulelaud		1	18x90	2360
GL1 40856	Gable moulding - Giebelleiste - Planche de rive - Finitura per frontale e retro del tetto - Gevellijst - Tablero de frontón - Viitulaud		1	18x120	2736
GL2 43031	Gable moulding - Giebelleiste - Planche de rive - Finitura per frontale e retro del tetto - Gevellijst - Tablero de frontón - Viitulaud		2	18x120	2800
HS8 5105	Screw for corner fillet - Schraube zur befestigung deckleiste - Vis pour profils de finition angles a l'exterieur - Viti per massellino d'angolo - Schroef voor afdeklijst (hoek) - Tornillo para molduras de esquina - Kruvi nurgaliistudele		60	3.5x35	
HS4 5102	Screw for fascia boards - Schrauben für traufbretter - Vis pour fixation bandeau de toit - Viti x striscia del tetto - Schroef voor gevellijst - Tornillo para tablero de alero - Kruvi räästalauale		12	3x30	
HS12 5109	Screw for covering moulding - Schrauben für deckungsprofil - Vis de fixation profils horizontaux haut intérieur et extérieur d'encadrement de porte - Vite per cornice di copertura - Schroef voor afdekprofiel - Tornillo para tablero delimitador - Kruvi piirdelauale		36	4x40	
HS12 5109	Screw for fixing fillet of door and window - Schrauben für fixierungsleiste - Vis pour profil vertical de fixation pour ouvertures des fenetres et portes - Viti per massello di fissaggio - Schroeven voor bevestiging van deur en raam lijsten - Tornillo para molduras en T - Kruvi tenderlijstudele		34	4x40	
HS12 5109	Screw for gable moulding - Schrauben für giebelleiste - Vis pour fixation planche de rive - Vite per fissare finiture davanti e dietro del tetto - Schroef voor gevellijst - Tornillo para tablero de frontón - Kruvi viitulauale		22	4x40	
HS13 5110	Screw for wall mounting - Schrauben für wandmontage - Vis de fixation au mur - Viti per montaggio a parete - Schroef voor wandmontage - Tornillo para montaje de pared - Kruvi seinte montaaziks		340	4x60	
HS13 5110	For the window frame - Für den Fensterrahmen - Pour le cadre de la fenêtre - Per il telaio della finestra - Per il telaio della finestra - Para el marco de la ventana - Akna lengile		8	4x60	
HS18 5113	Screw for roof beams - Schrauben für dachbalken - Vis pour fixation pannes de toit - Viti per perline del tetto - Schroef voor gordingen / dakbalken - Tornillo para correas - Kruvi pärlinitele		4	5x120	
SH28 32509	Hammer block - Schlagholz - Calle de frappe - Blocco di legno da usare come cuscinetto quando si usa il martello - Slagklos - Bloque de impacto - Löögiklots		1		
NF4 5137	Zn nail for roof - Zn nägel für dachbretter - Pointe pour fixation voliges de toit - Chiodi x perline tetto - Spijker(nagel) voor dakhout - Clavo para tablero de tejado - Nael katuselauale		125	2x50	
NF5 5145	Zn nail for roofing felt fillet - Zn nägel für dachpappenleiste - Pointe pour baguette de fixation feutre bitumeux - Chiodi x carta bituminosa x tetto - Spijker(nagel) voor asfaltpapier afdekljst - Clavo de moldura de fieltro - Papiilistunael		18	2x40	
40065	Door - Tür - Porte - Porte - Deur - Puerta - Uks 1494x1850 TUL.2.050.IVP.MMX28 TA+28		1		
43035	Window - Fenster - Fenetre - Finestra - Raam - Ventana - Aken 2445x340 AK.3.030.XM0.b XGA		1		

Art. Nr. 2851496

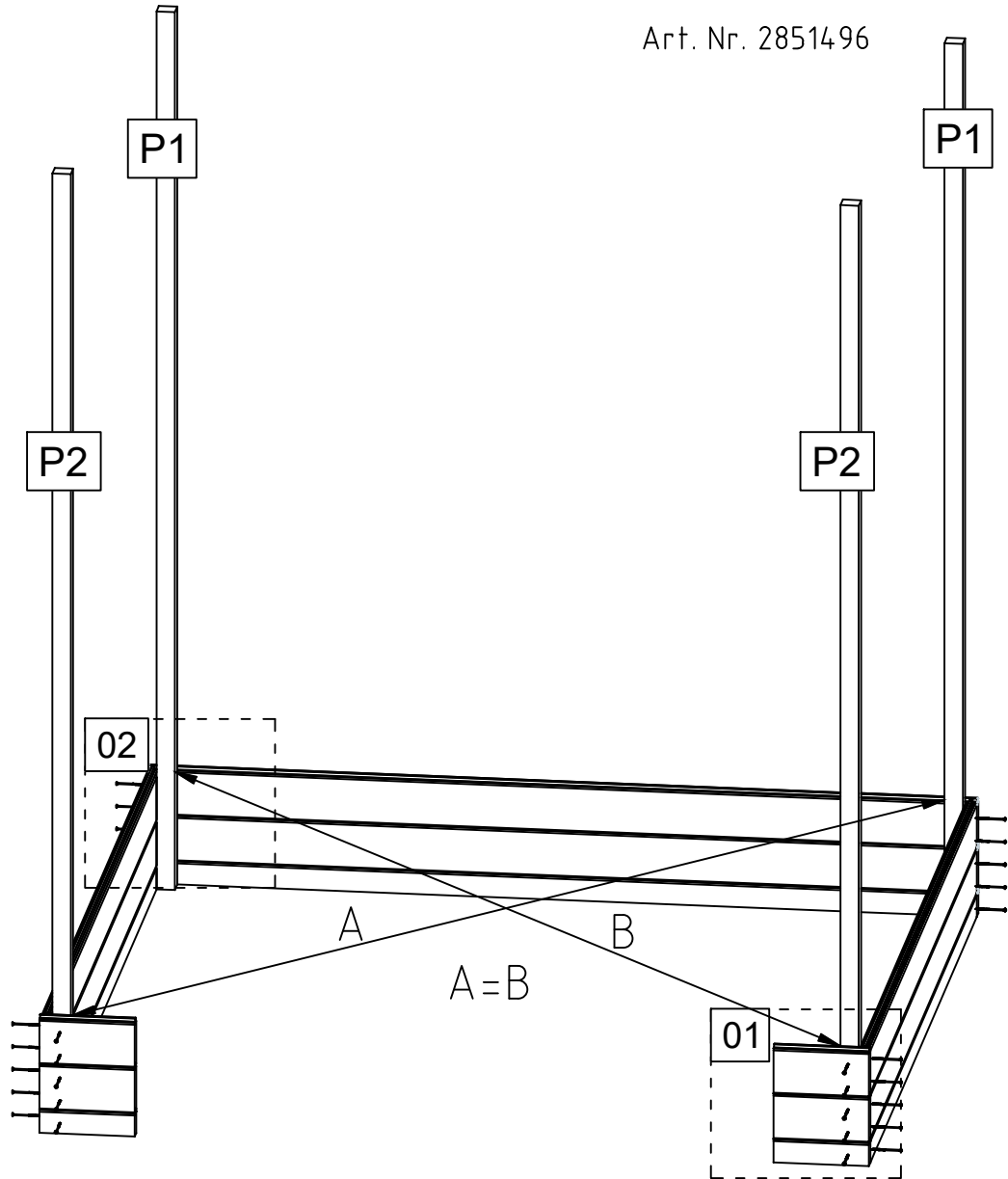

01

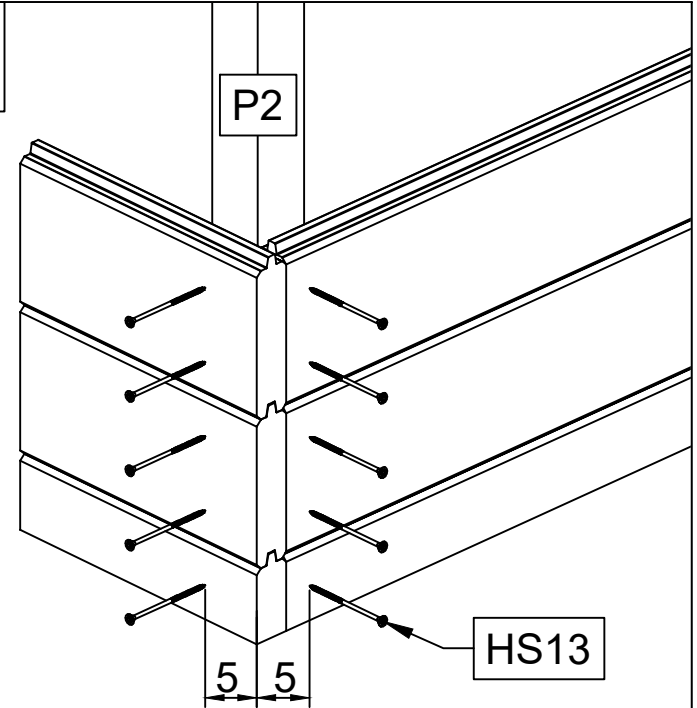

02

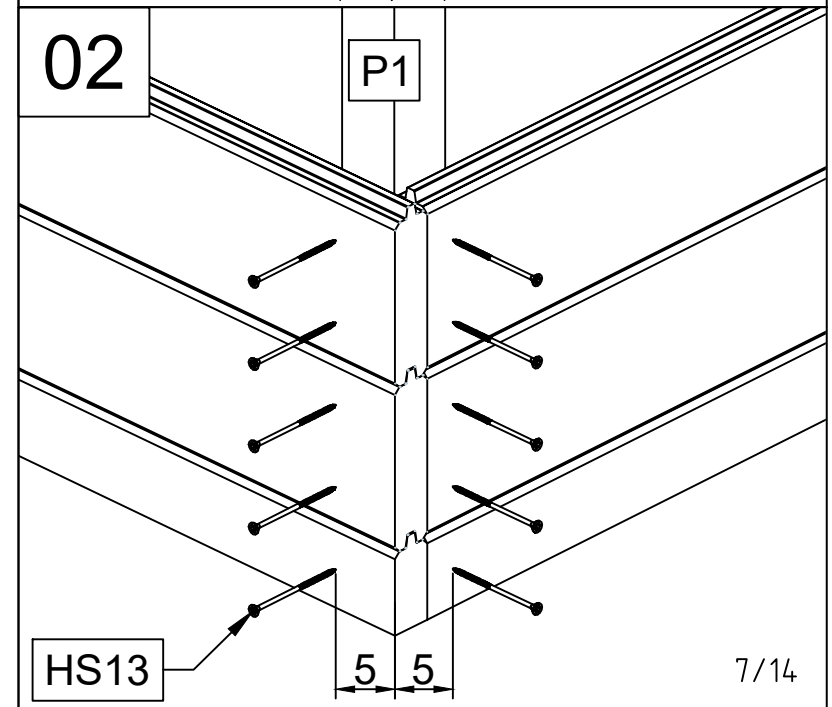

Art. Nr. 2851496

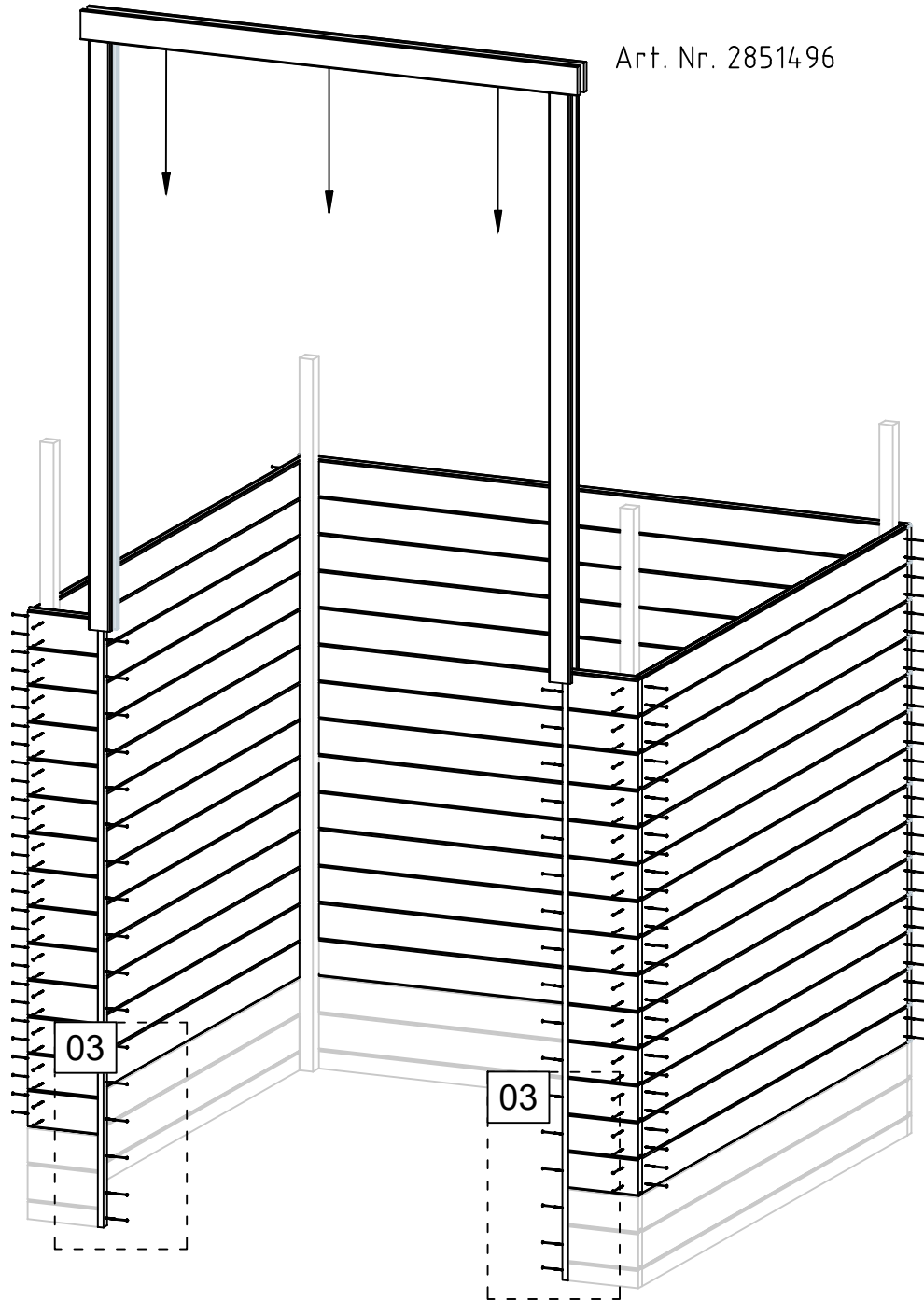

03

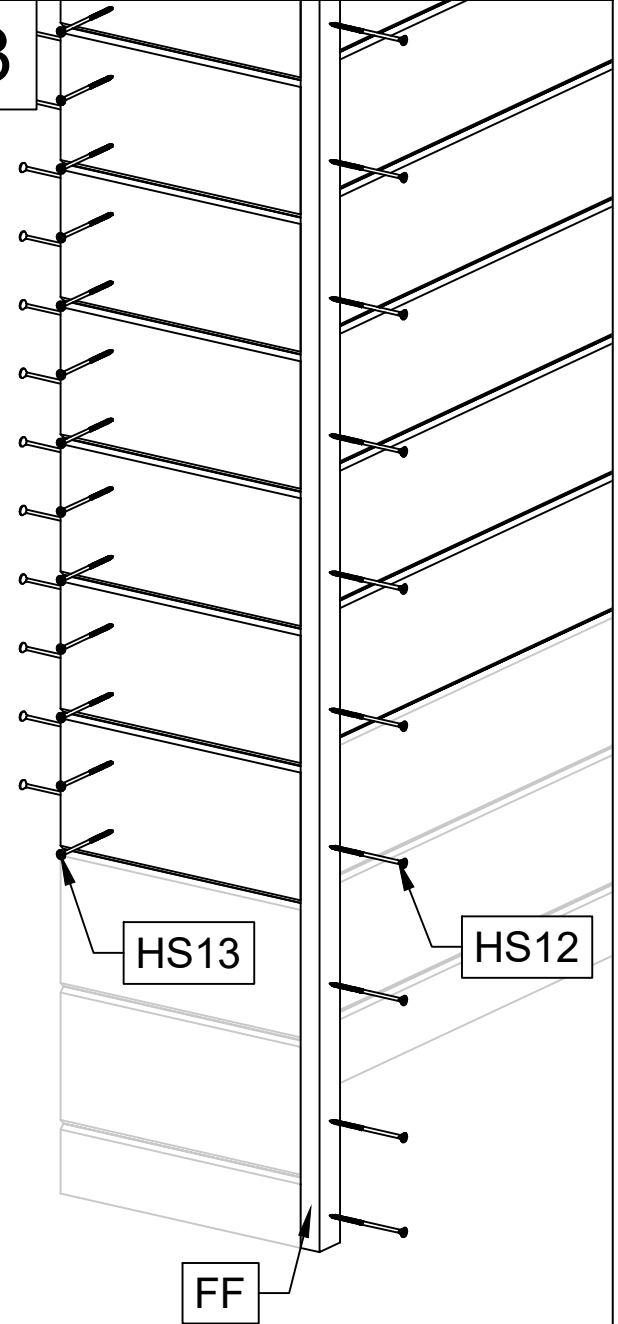

Art. Nr. 2851496

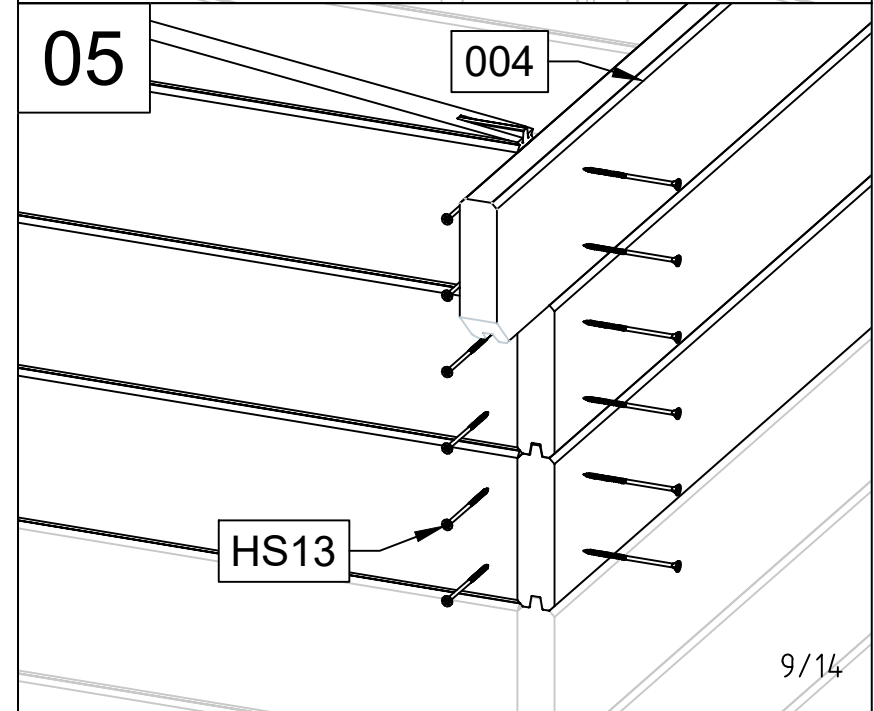
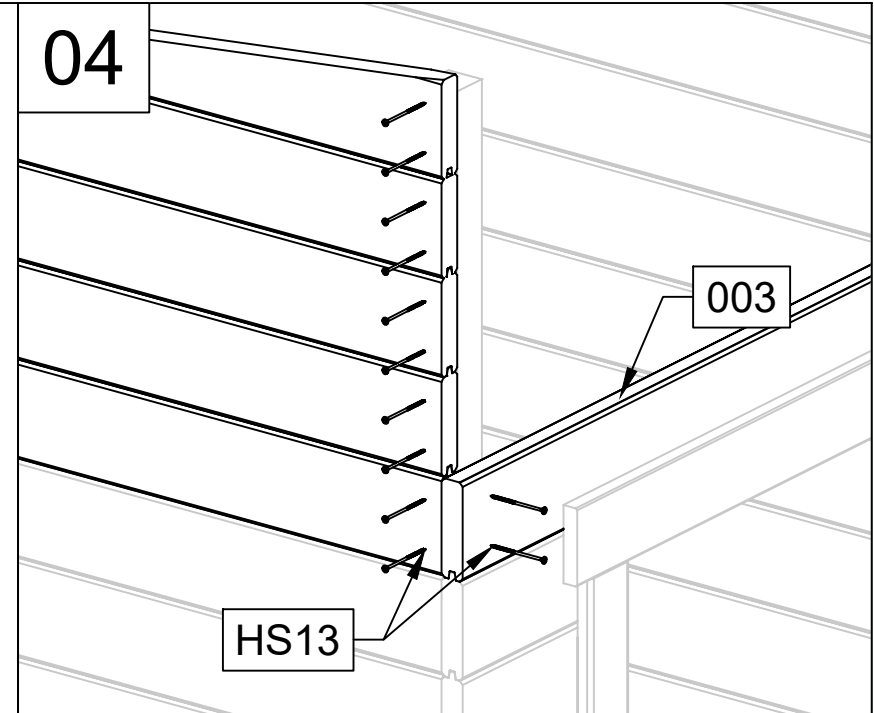
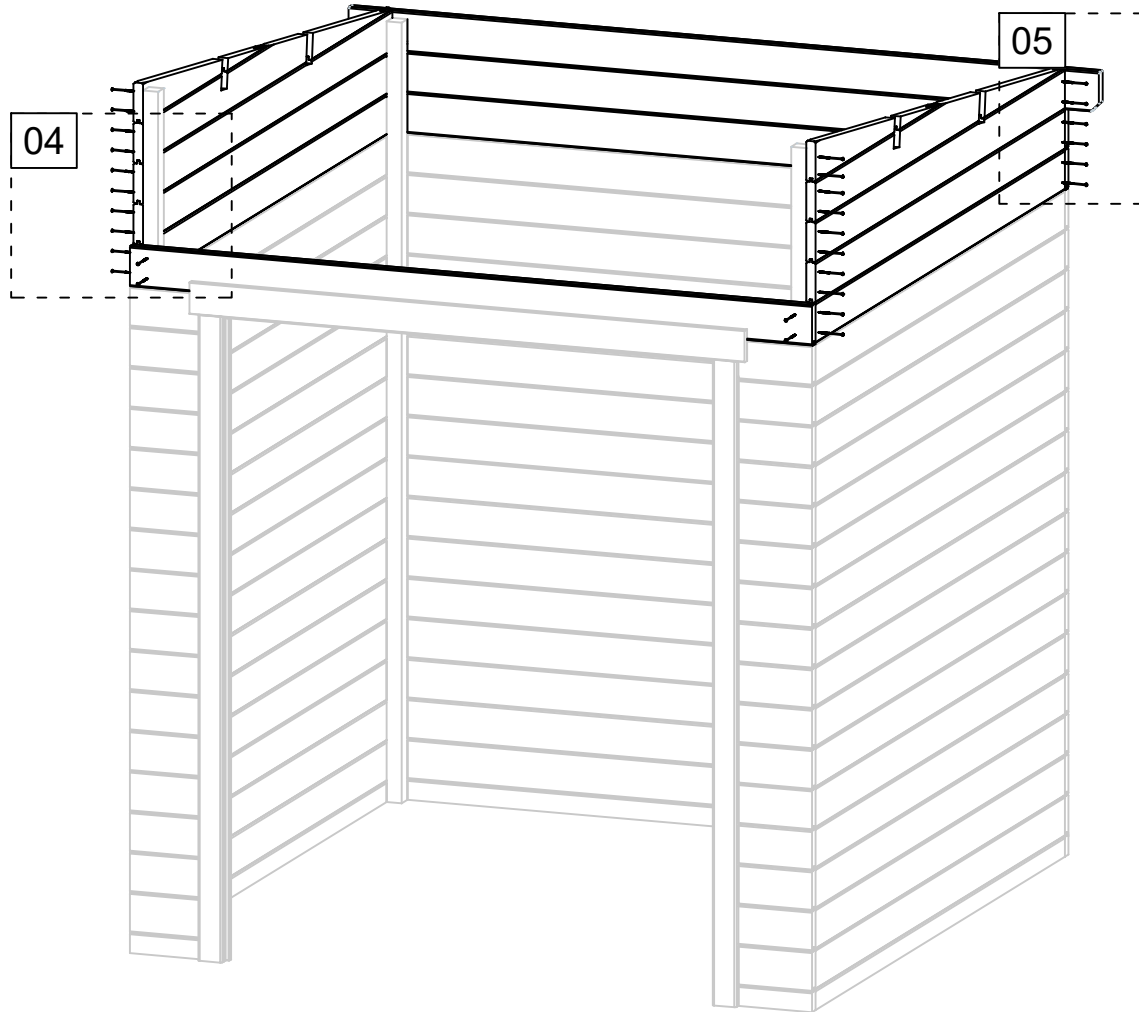

Art. Nr. 2851496

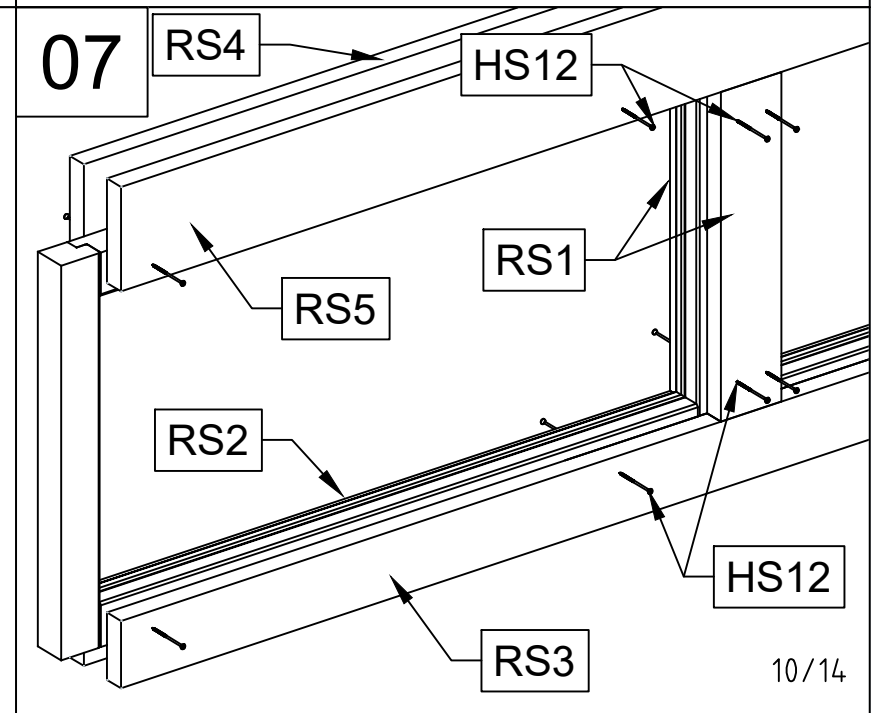
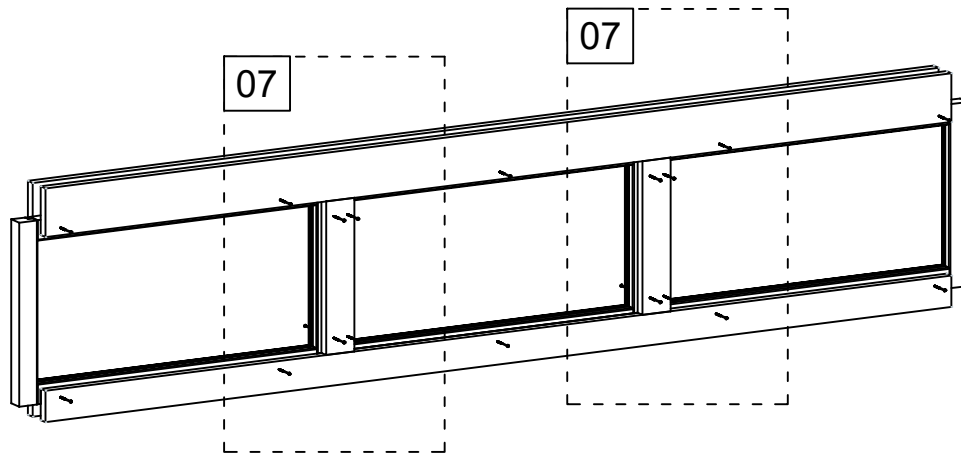
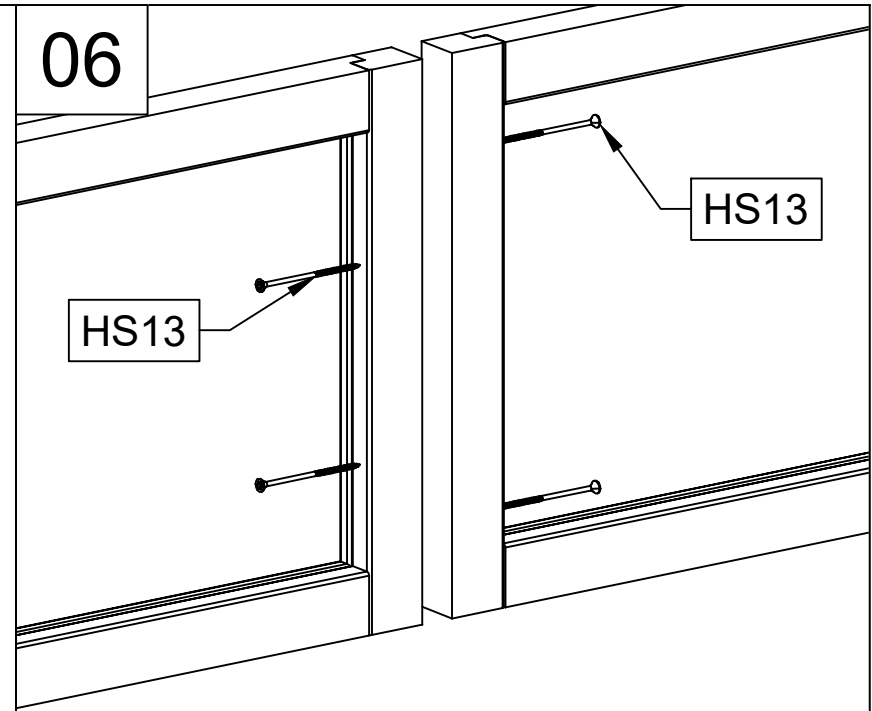
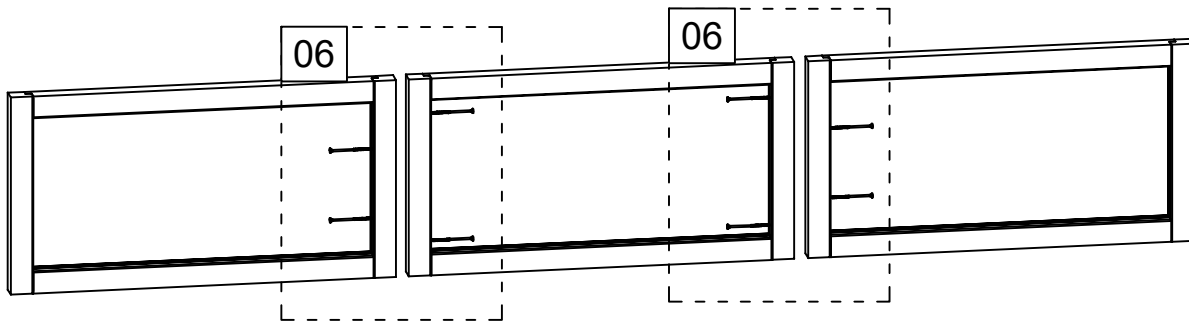

Art. Nr. 2851496

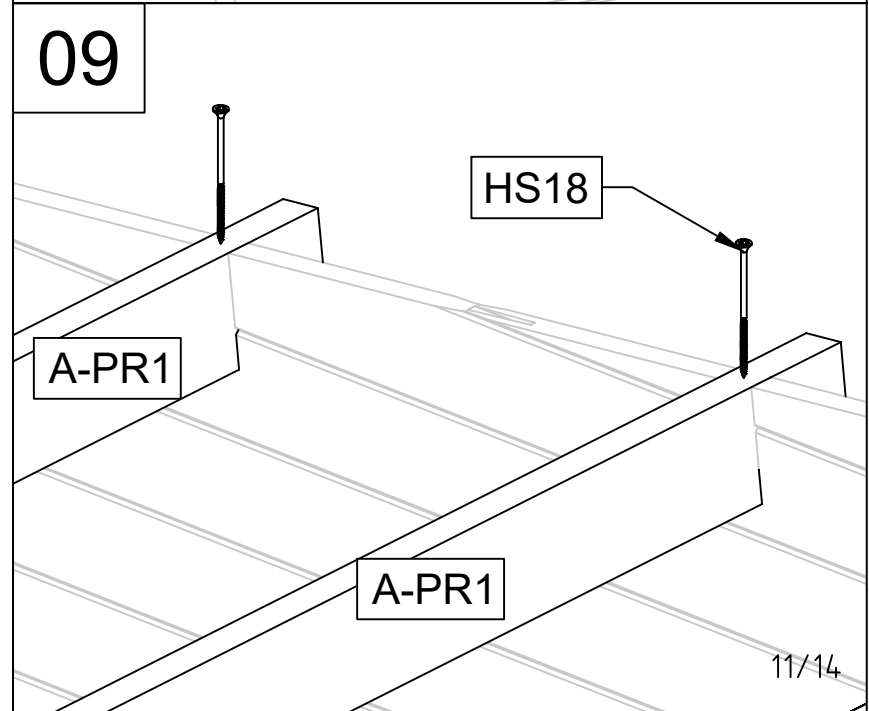
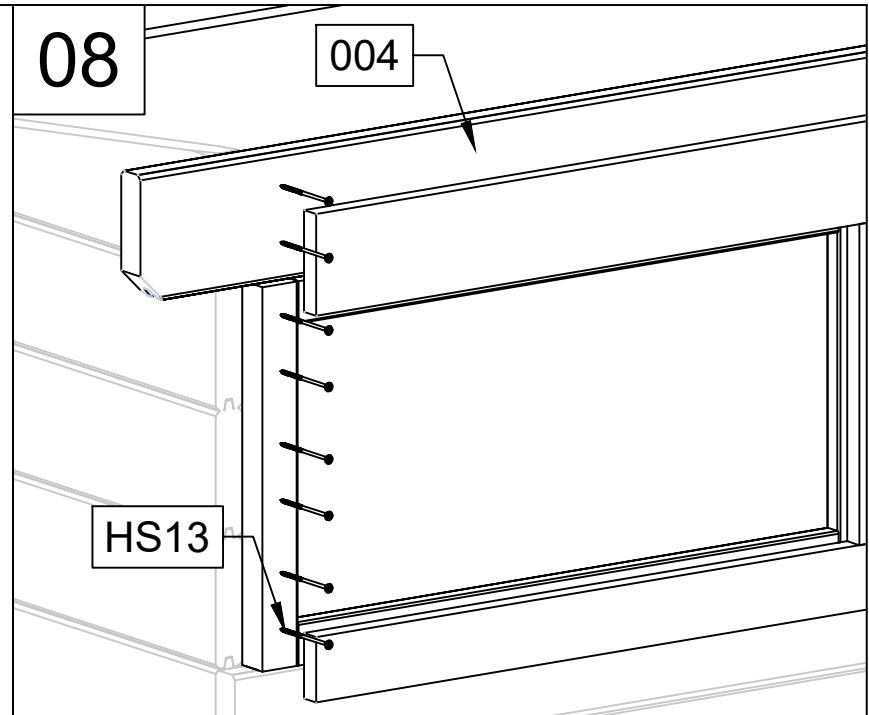
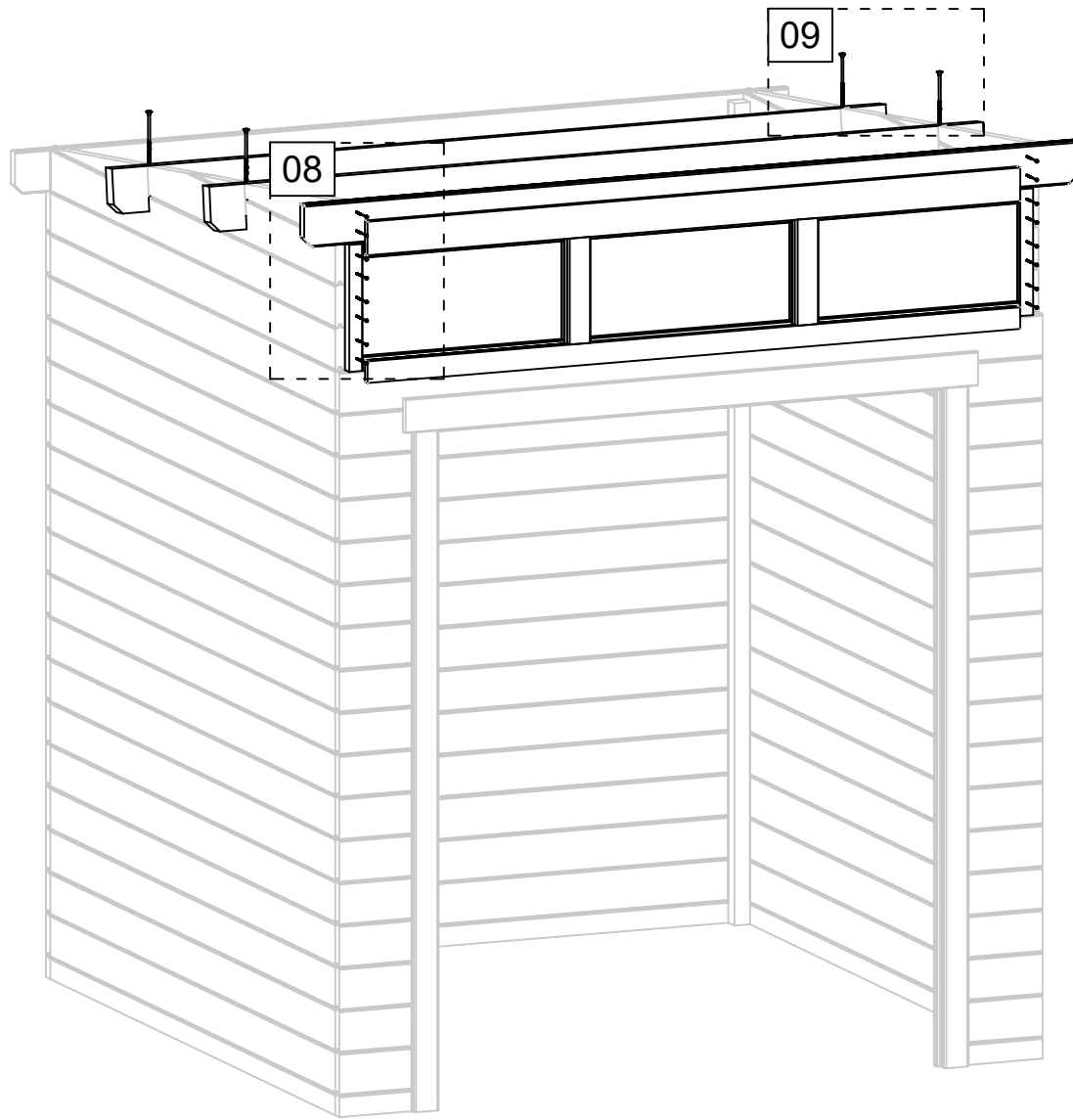

Art. Nr. 2851496

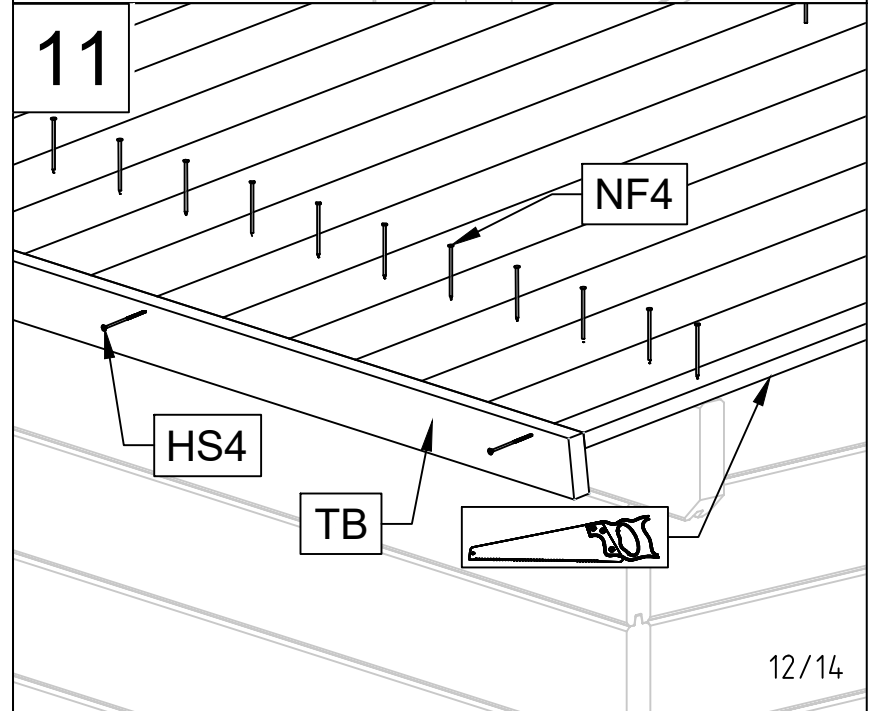
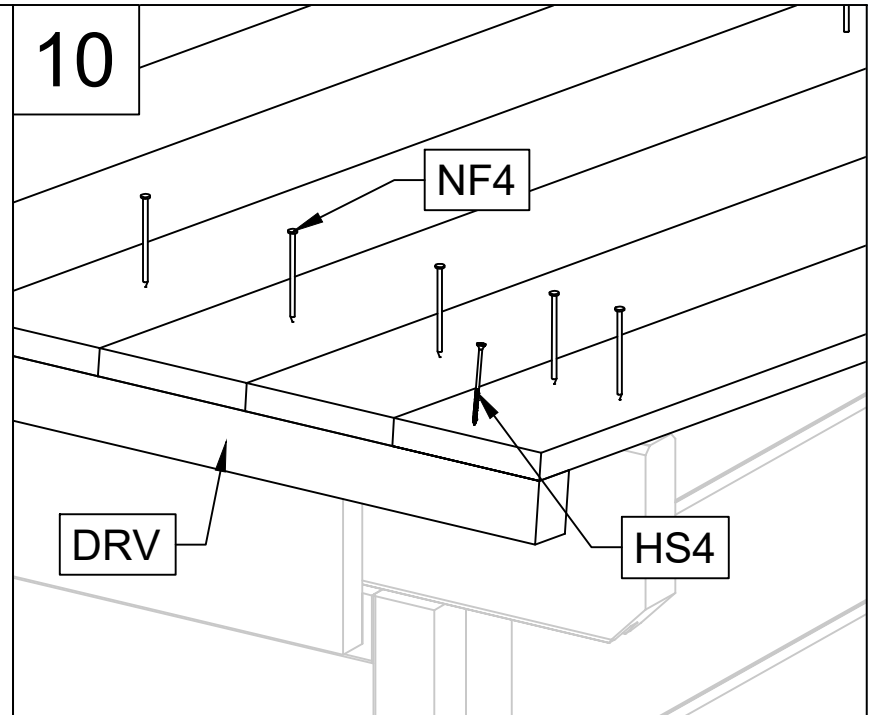
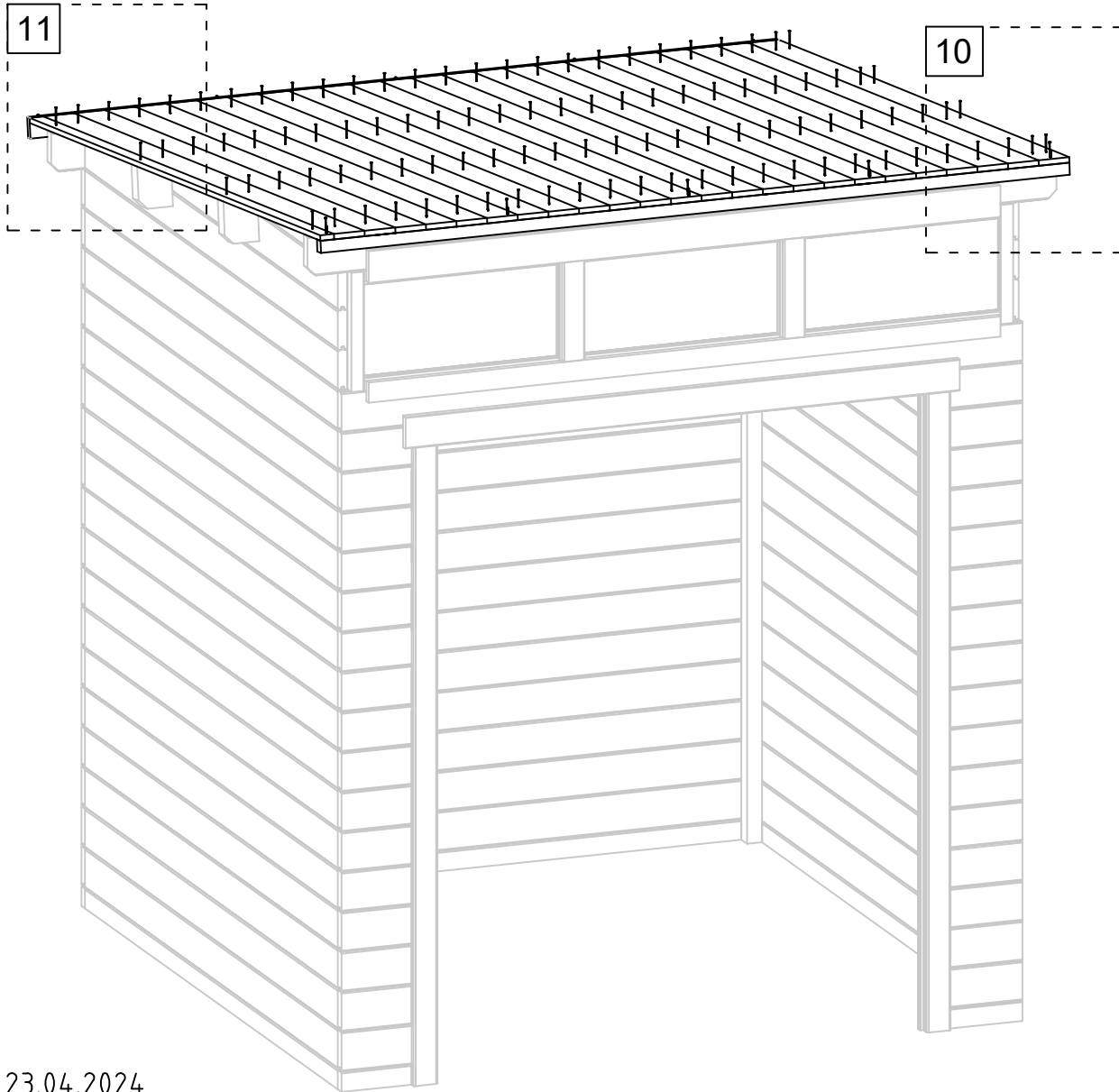

Art. Nr. 2851496

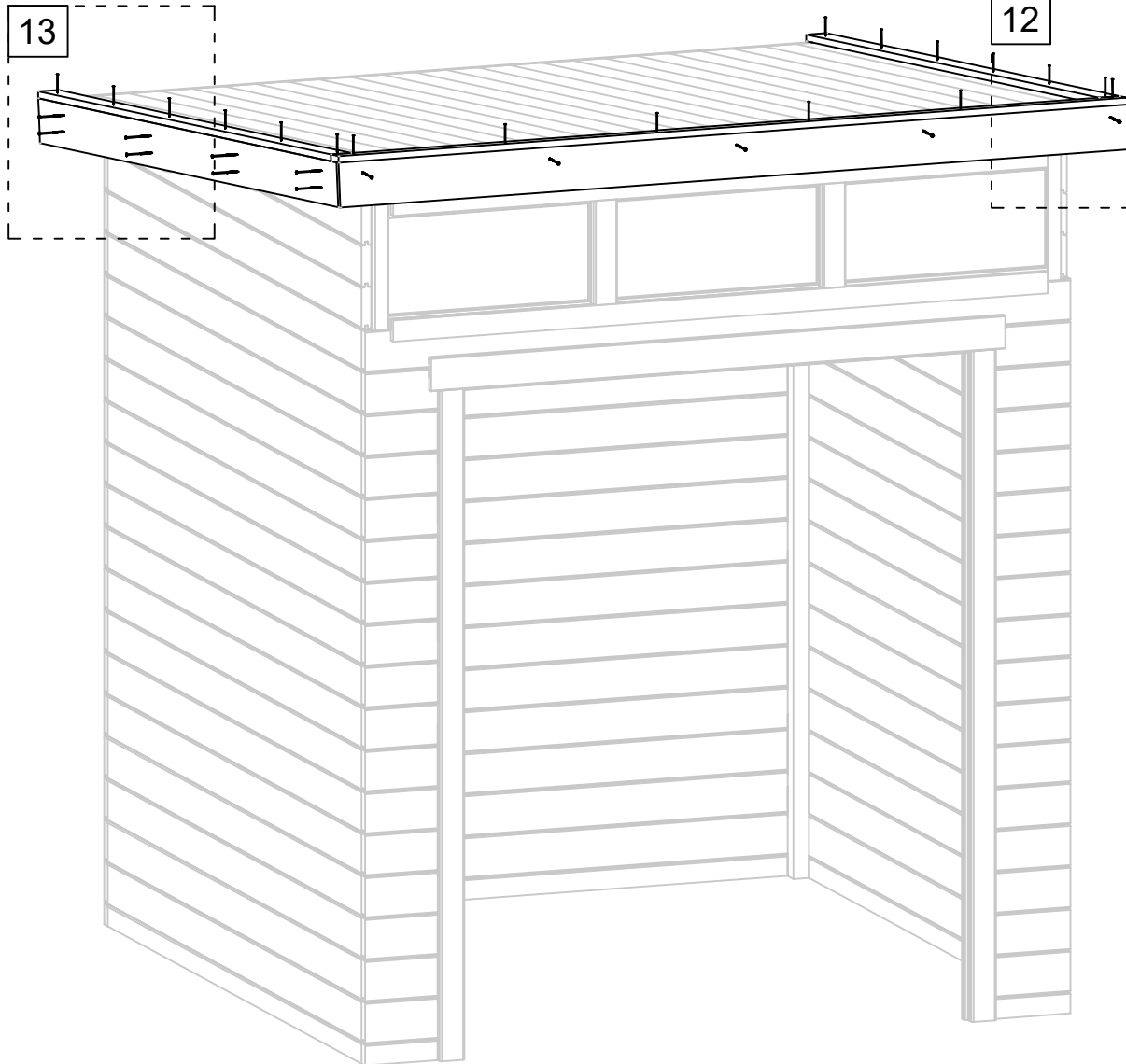

12

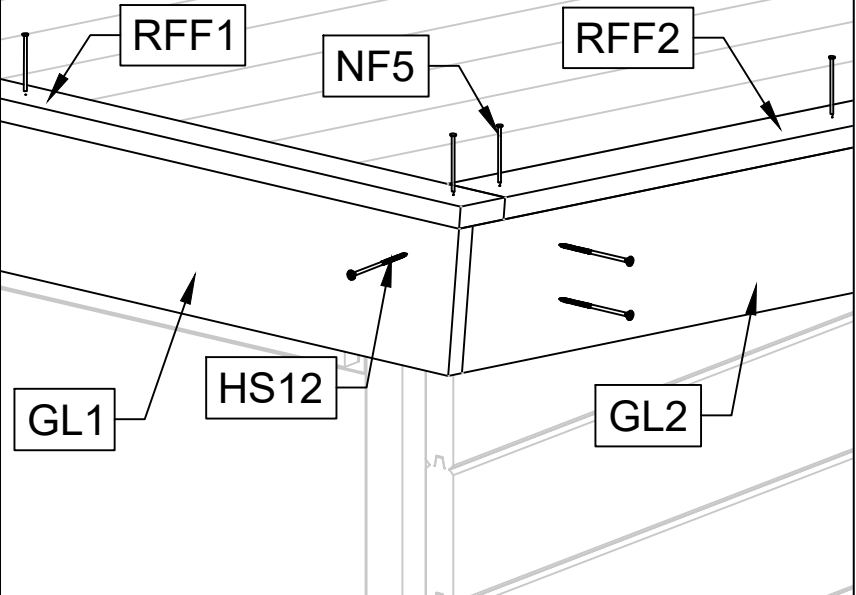

13

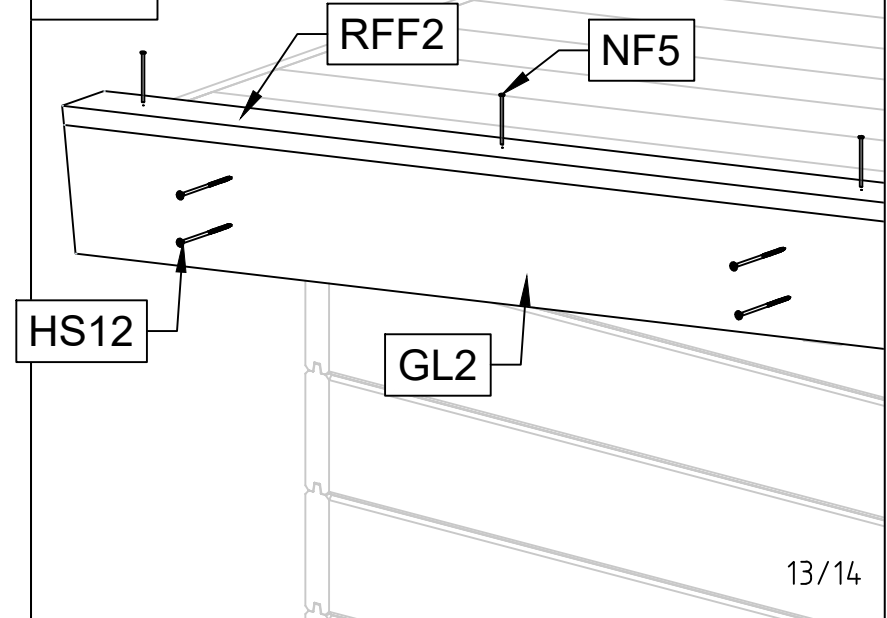

Art. Nr. 2851496

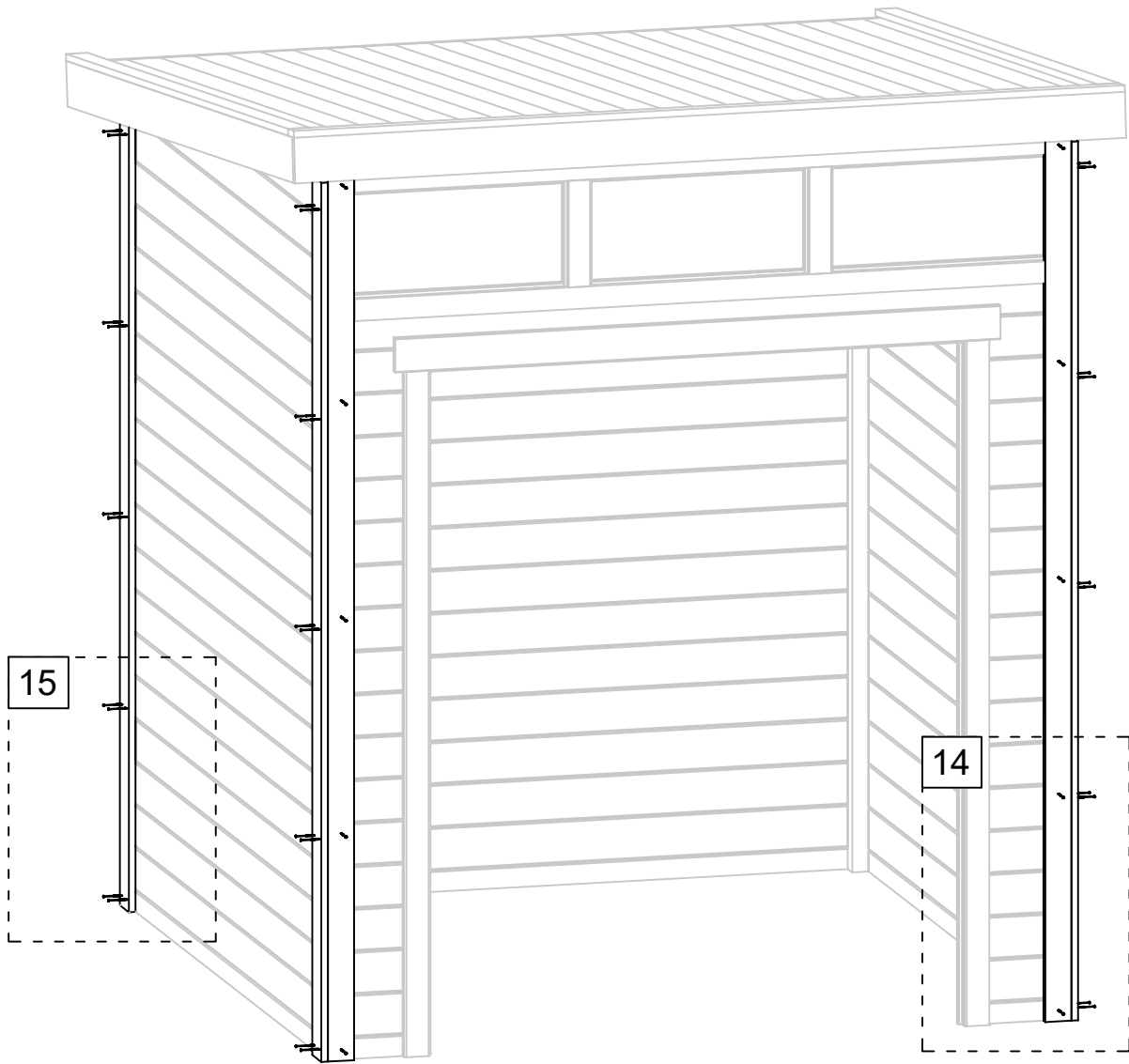

15

14

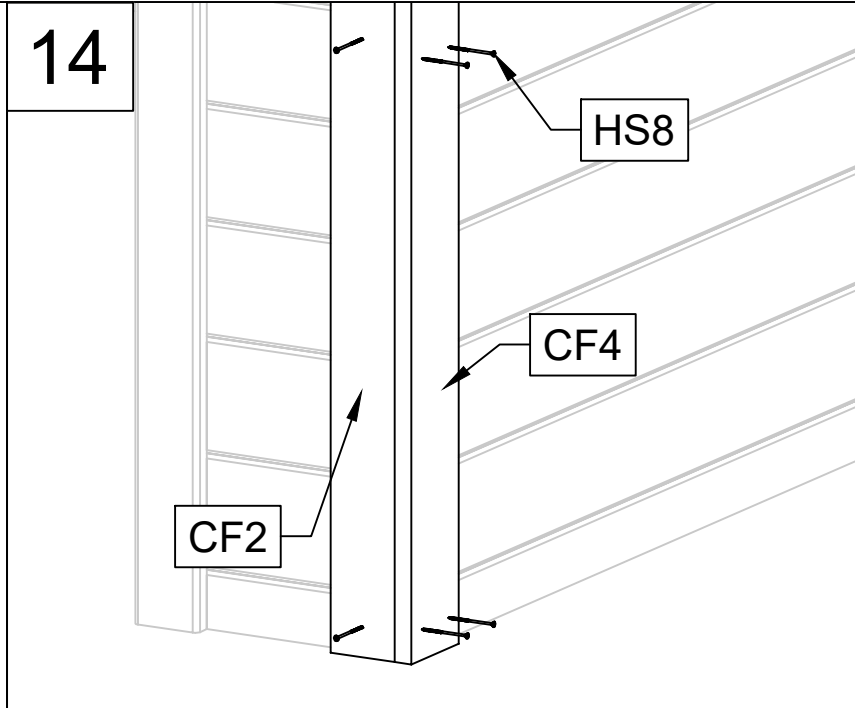

14

HS8

CF4

CF2

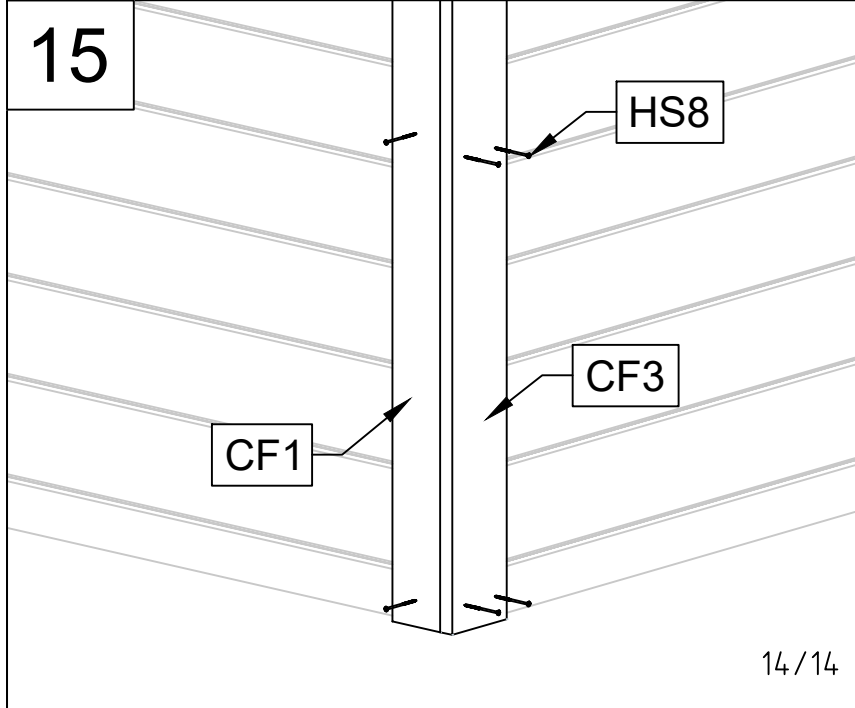

15

HS8





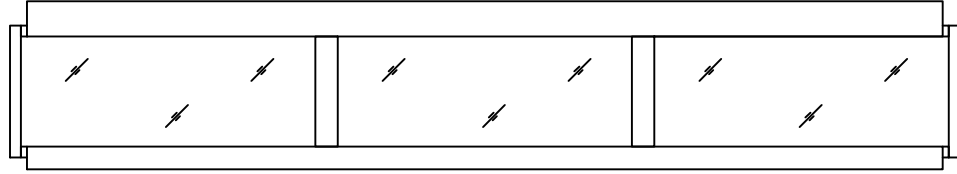

CF3

CF1

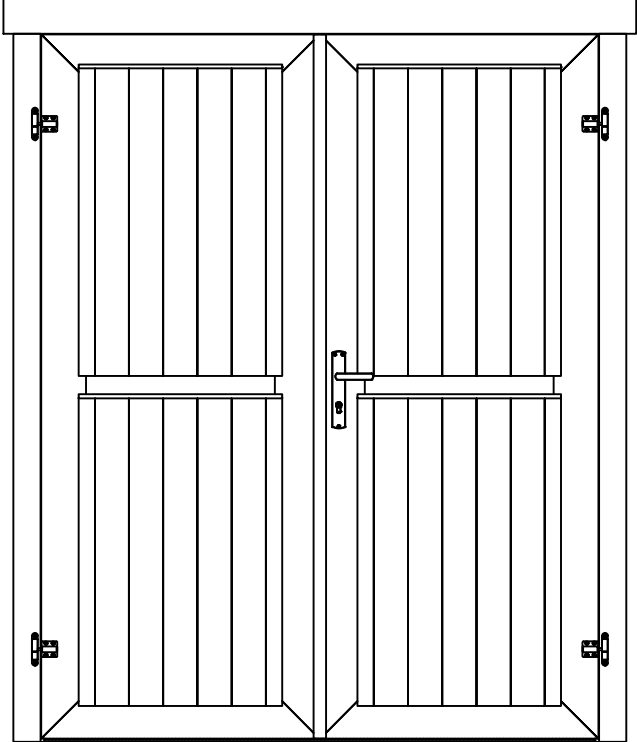
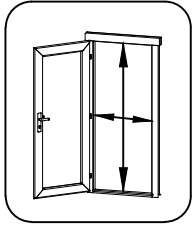
Pos	01.12.2021 Piece list - Stückliste - Liste des pièces - Elementi - Stuklijst - Tükitalabel 2445x340 AK.3.030.XM0.b XGA	1/1	Q	P (mm)	L (mm)
-----	---	-----	---	-----------	-----------

Glass size - Glasgröße - Taille de la vitre - Misura del vetro - Glas afmeting - Klaasi mõõt: 755x280 mm



Pos	27.11.2017	Piece list - Stückliste - Liste des pièces - Elementi - Stuklijst - Tükitabel 14.94x1850 TUL.2.050.IVP.MX28 TA+28	1/2	Q	P (mm)	L (mm)
		  <p>1418x1792 mm</p>				
1	Upper door jamb - Türrahmen oben - Cadre de porte supérieur - Telaio superiore della porta - Bovendorpel - Ukse ülemine leng		1	66x100	1628	
2	Left door jamb - Türrahmen links - Cadre de porte gauche - Telaio montante sinistro della porta - Linkerstijl deurframe - Ukse vasak leng		1	66x80	1850	
3	Right door jamb - Türrahmen rechts - Cadre de porte droit - Telaio montante destro della porta - Rechterstijl deurframe - Ukse parem leng		1	66x80	1850	
4	Doorstep - Swelle - Barre de seuil - Soglia della porta - Deurdorpel - Lävepakk		1	18x18	1418	
5	Connection strip - Deckleiste - Baguette de battement - Profilo verticale della porta - Stulplijst - Kokkuvaltsiliist		1	13x32	1812	

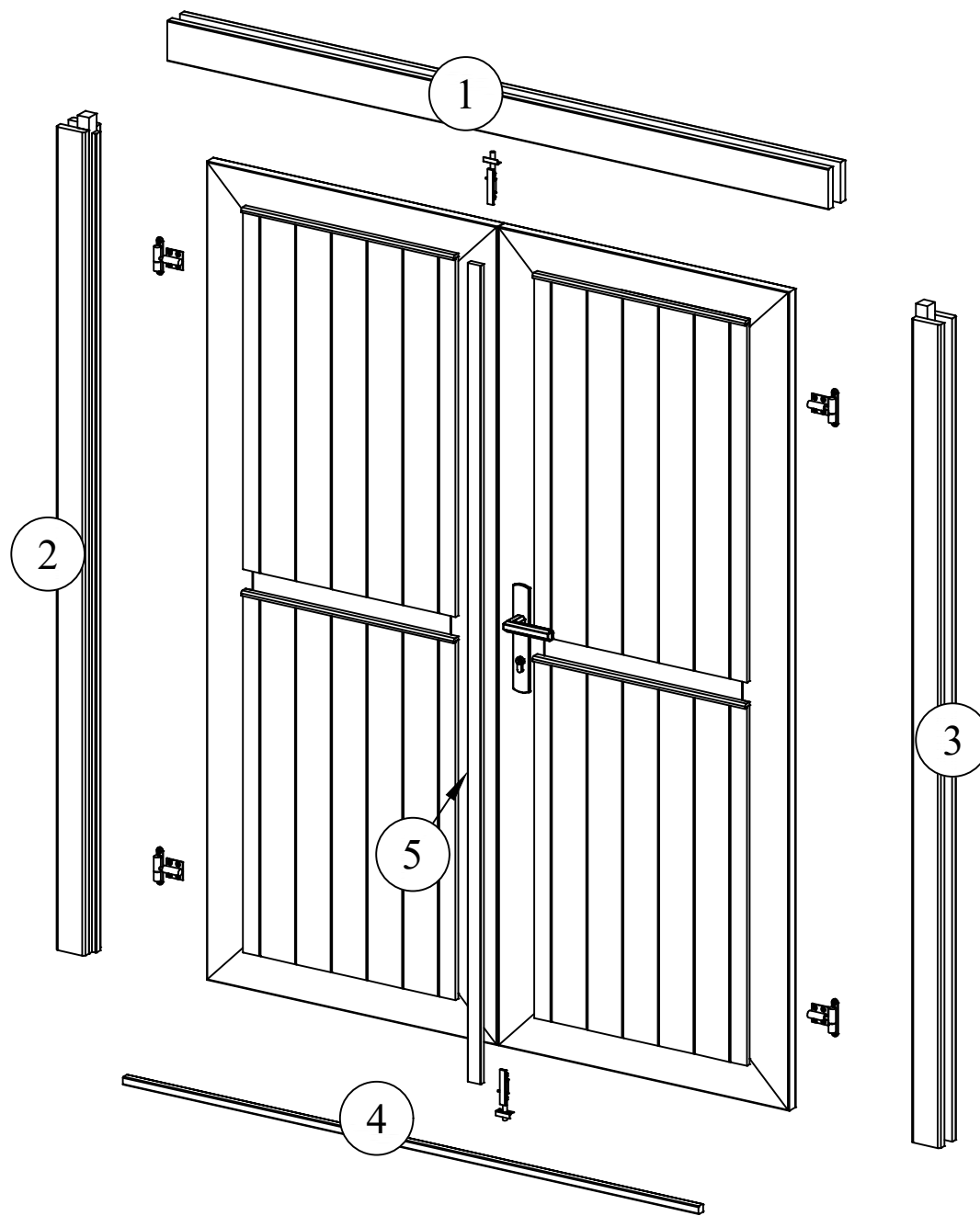

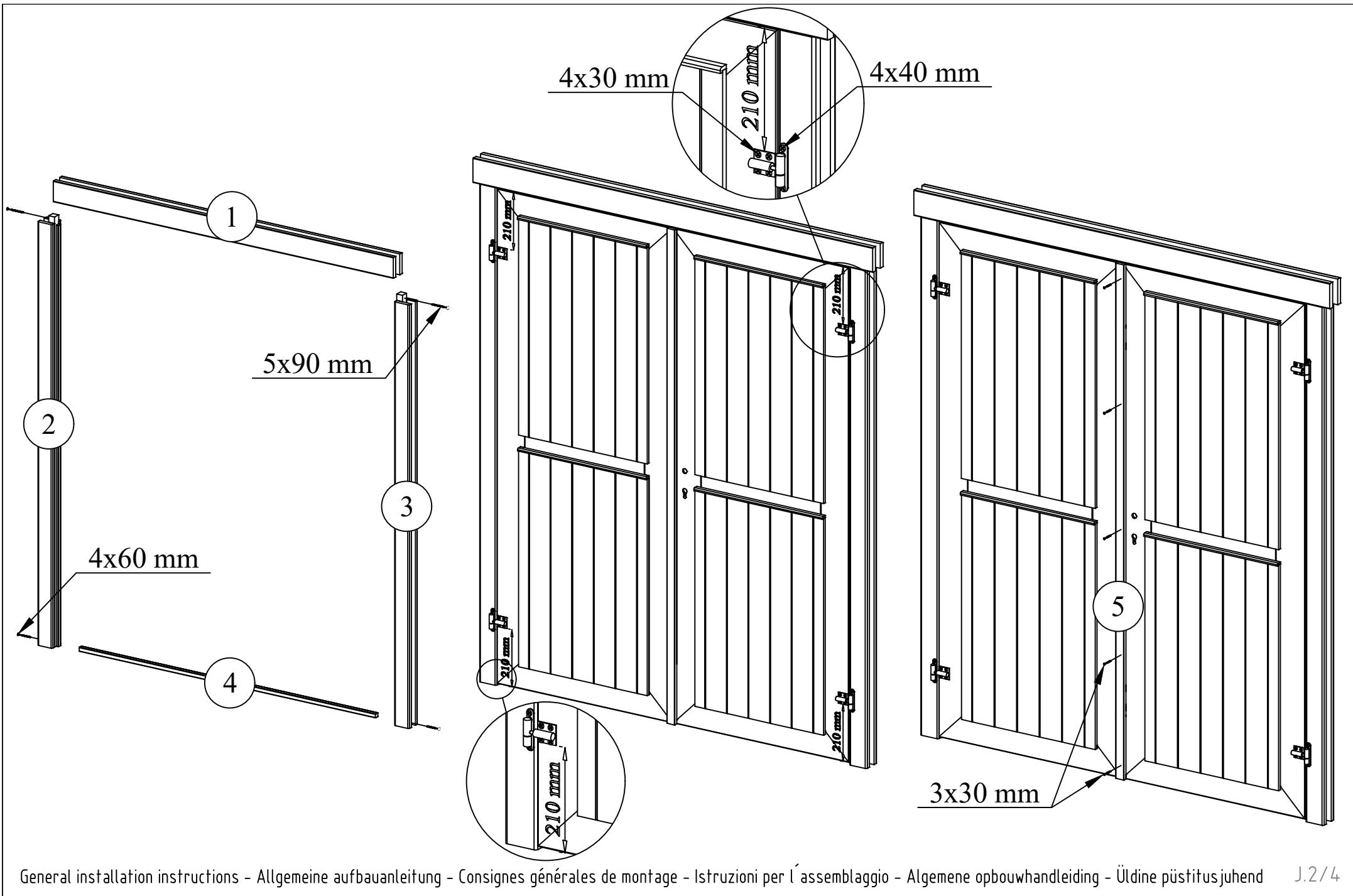

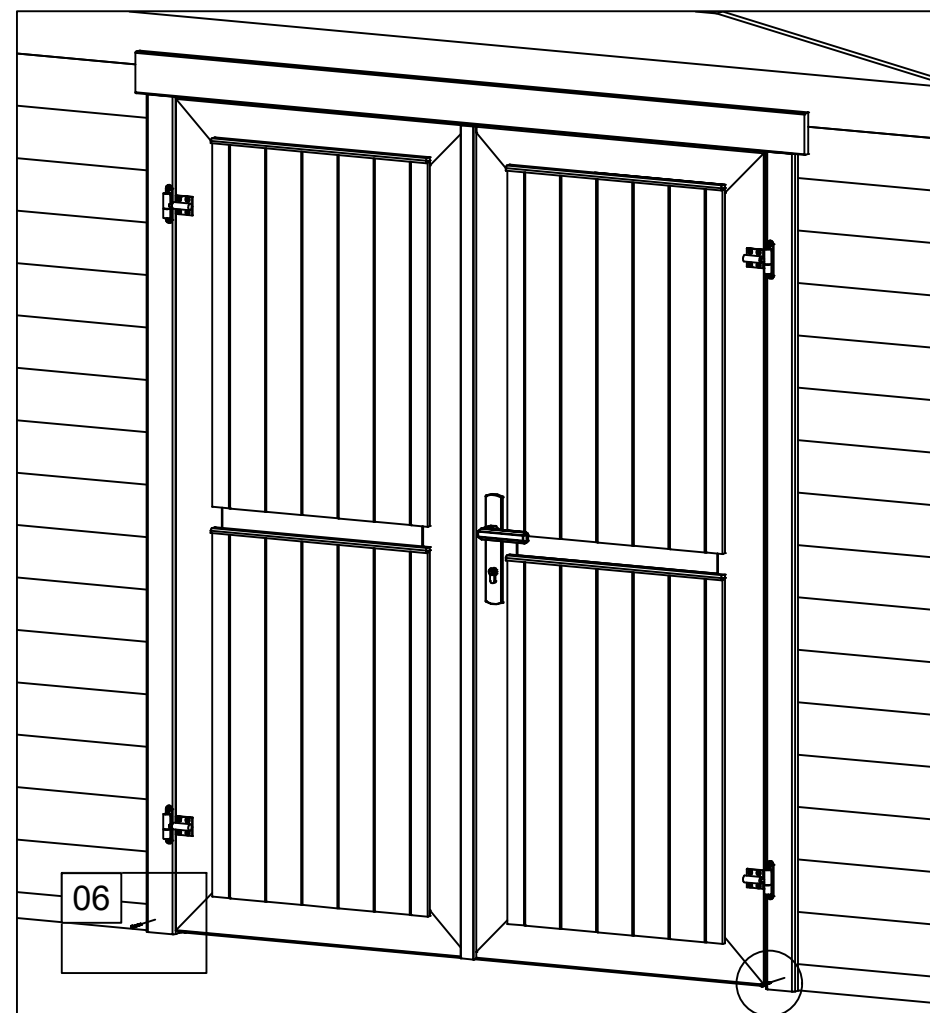
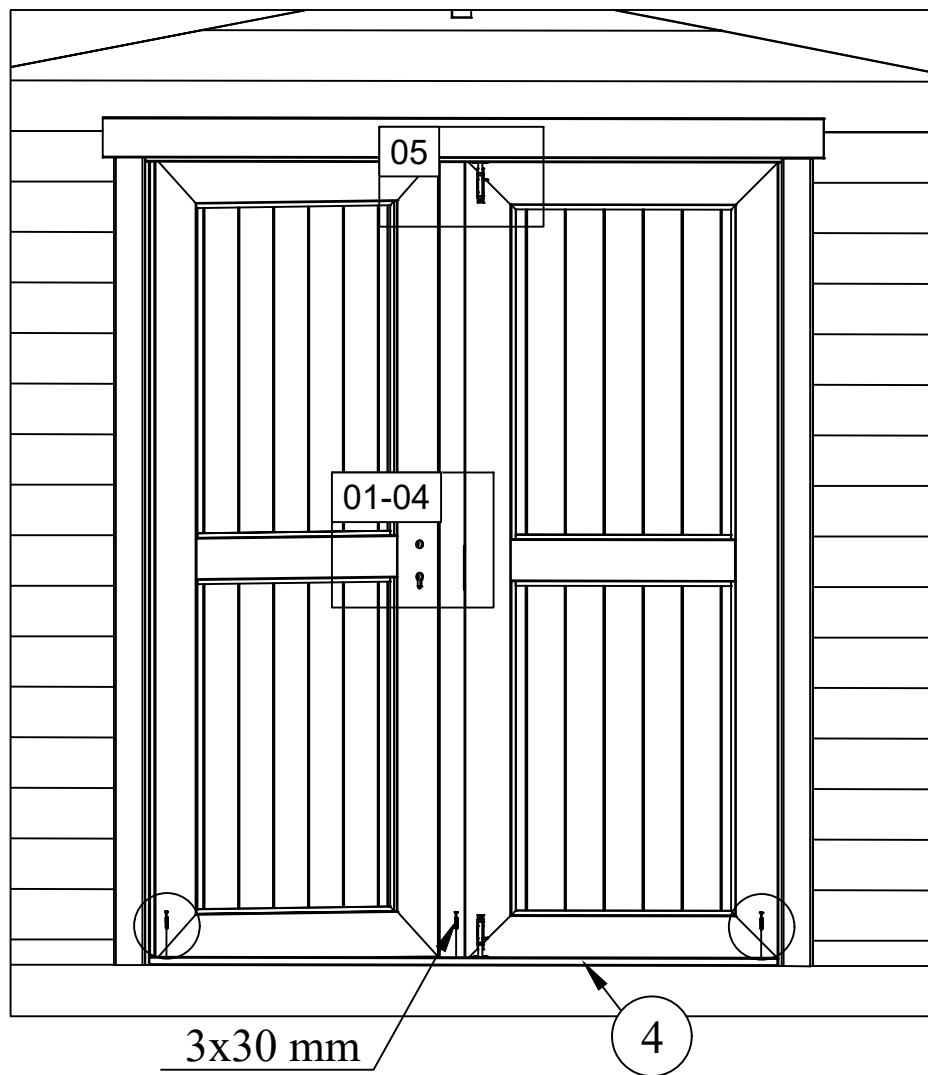

01

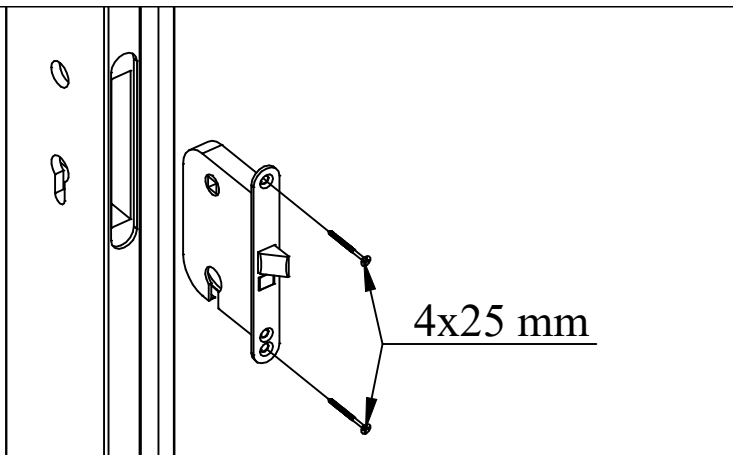

04

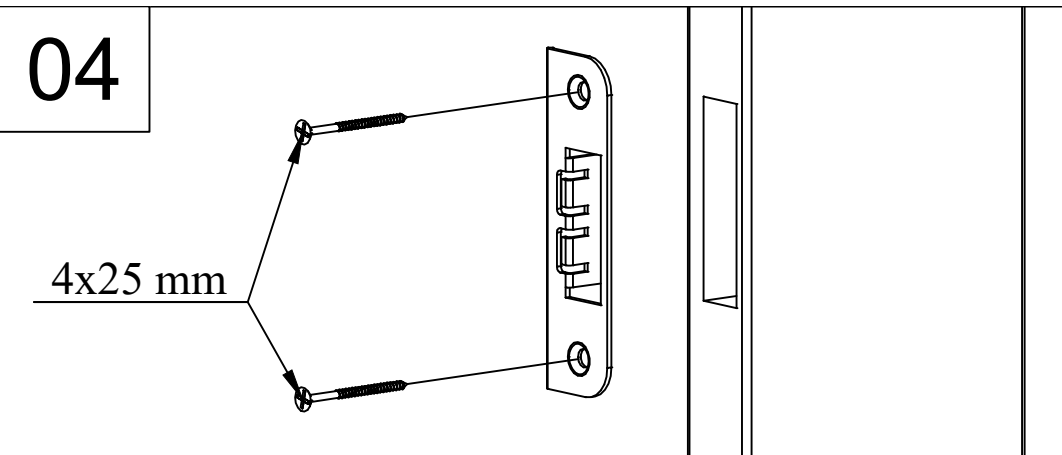

02

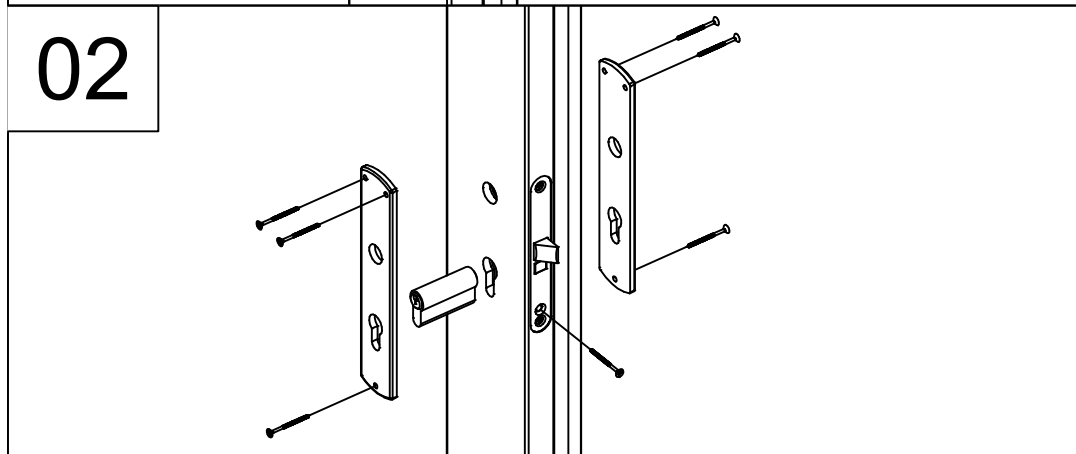

05

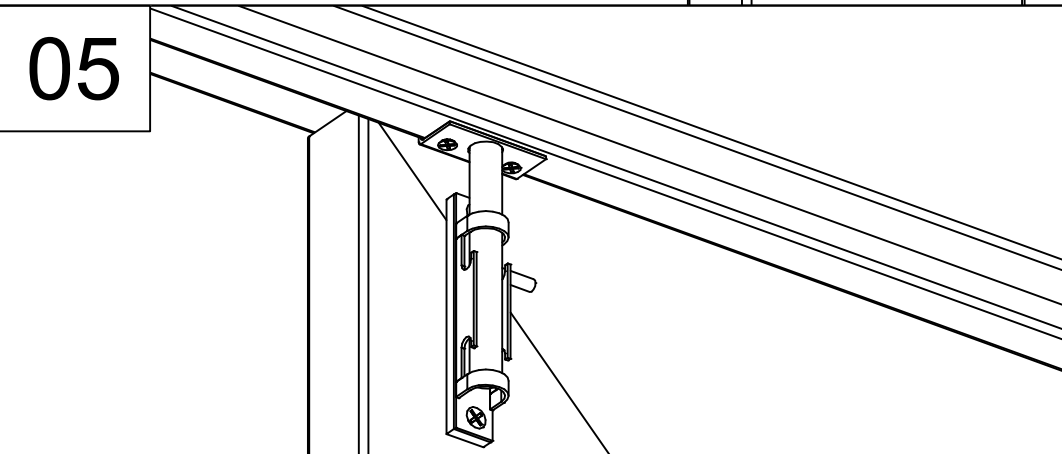

03

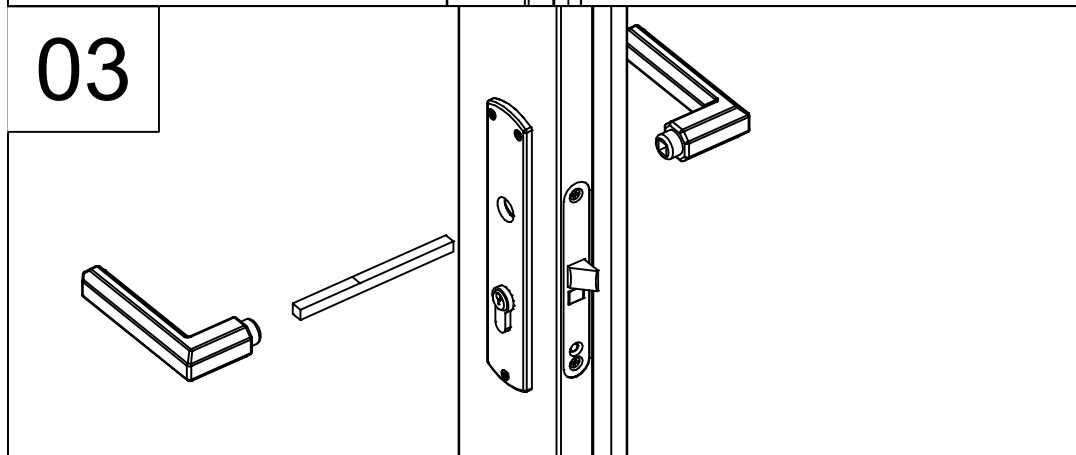

06

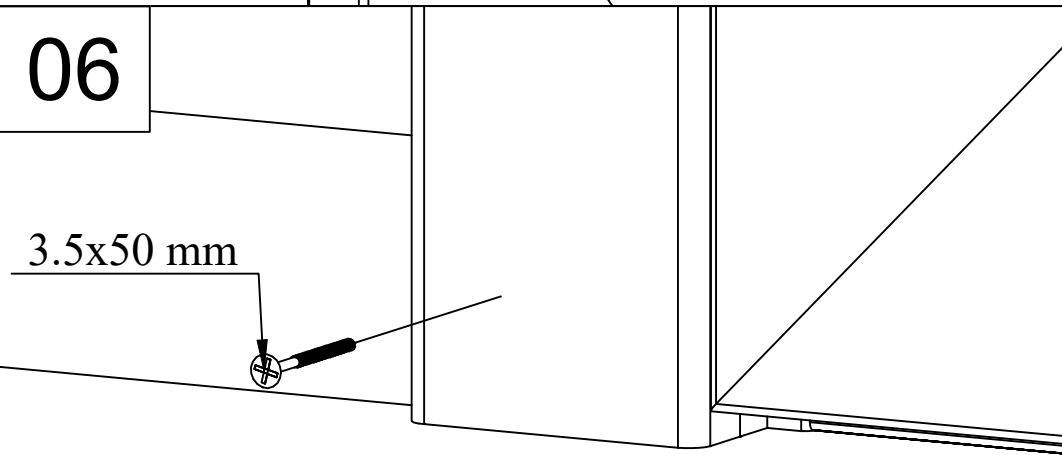

DANCOVER[®]

.com

Contact information

Austria



Belgium



Croatia

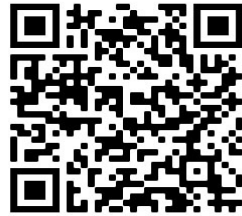

Denmark



Estonia

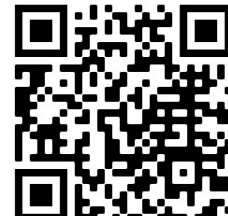

Finland

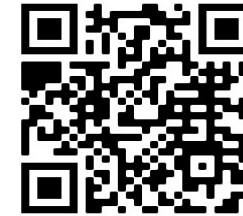

France

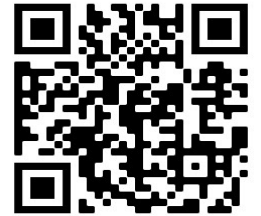

Germany



Ireland



Italy



Latvia



Lithuania



Nederland

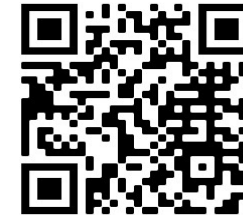

Norway

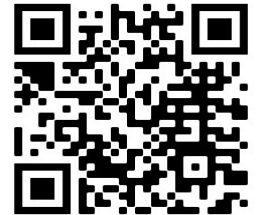

Poland

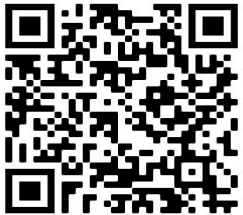

Portugal



Spain

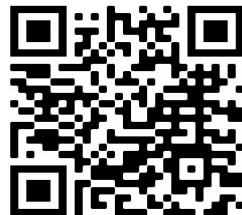

Sweden



Switzerland



UK



For more information please visit: www.dancovershop.com