

MODULARO®

WOOD SHED MOLDE

6,81x2,92x2,11m



16-03-2026

Art. Nr. WC165450
1/6



15.07.2024

Art. Nr. 2824696

Groundplan - Grundplan - Plan de masse - Planimetria -
Plattegrond - Põhiplaan

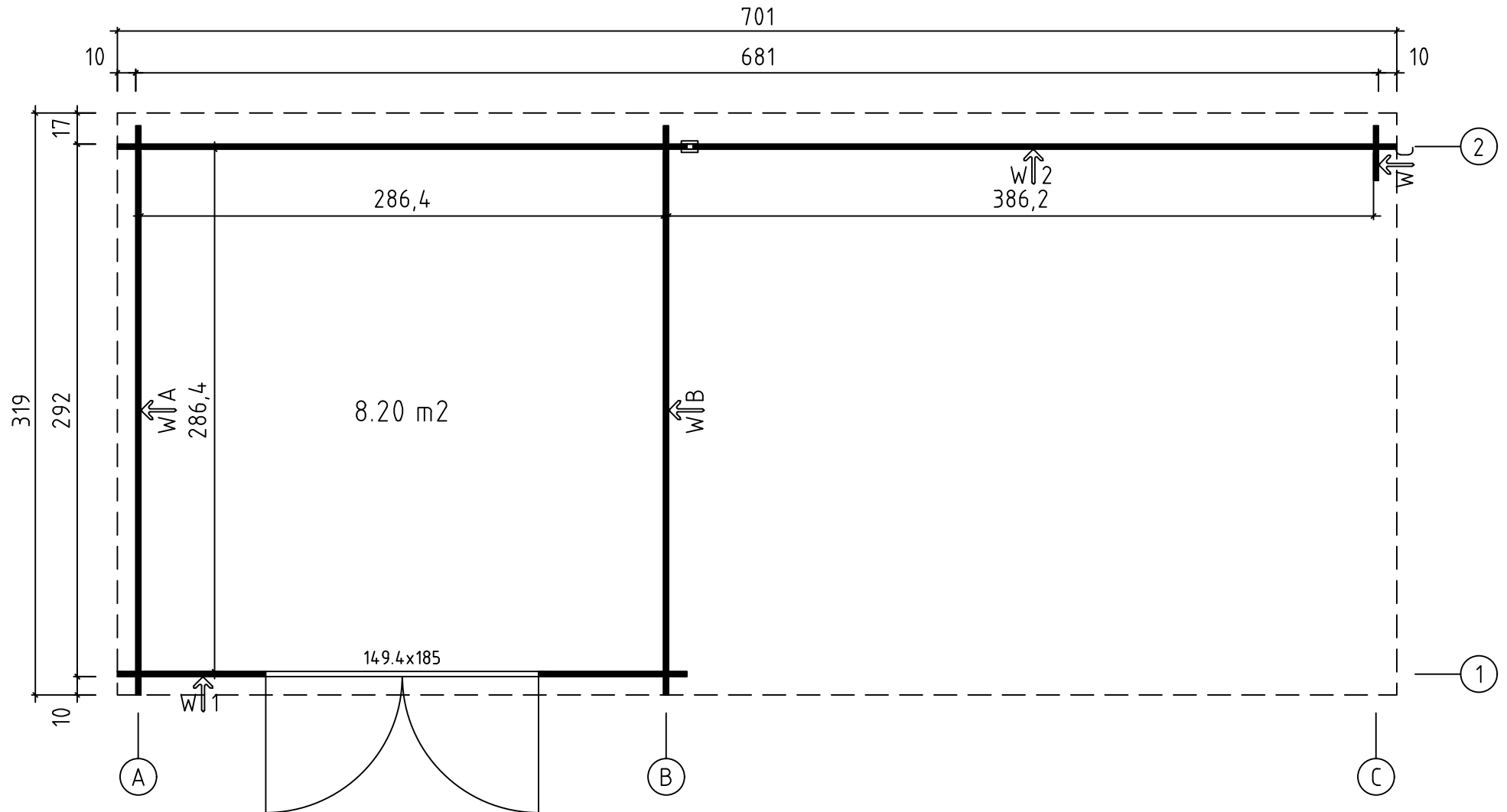





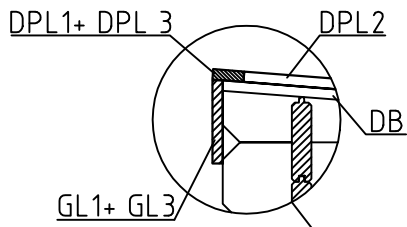



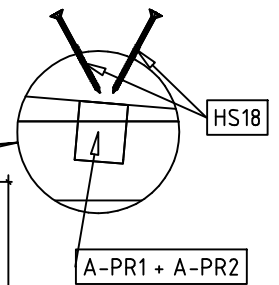
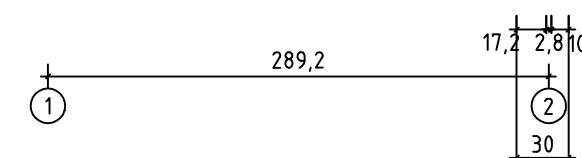
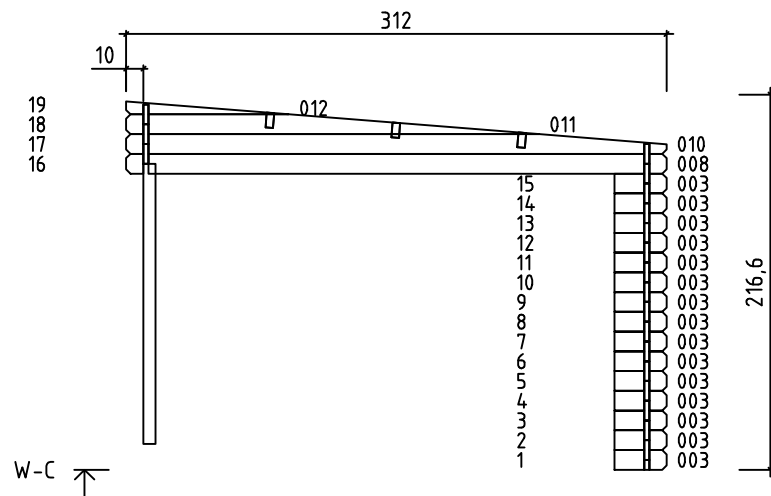
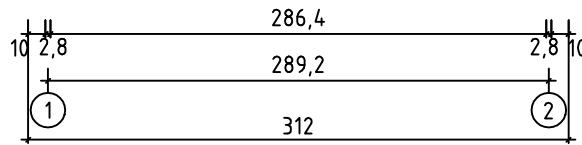
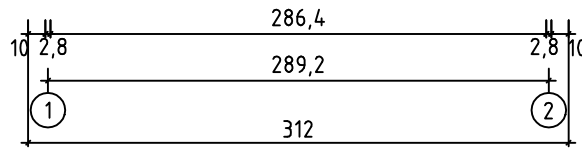
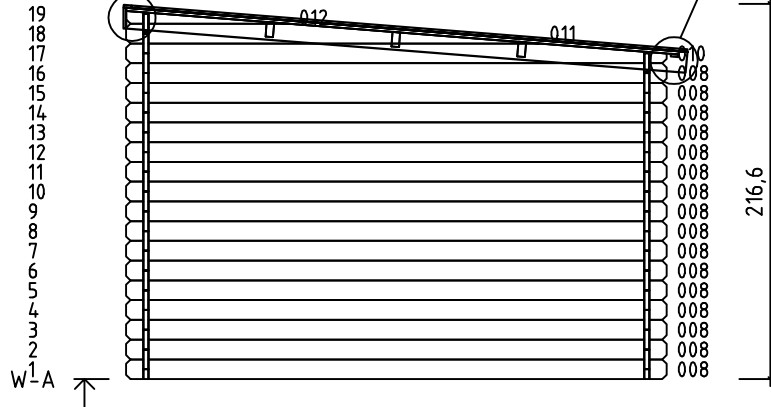
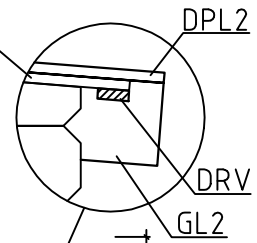

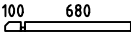
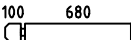

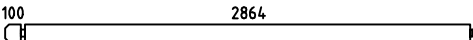
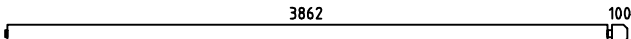
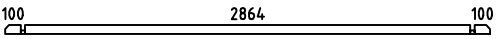
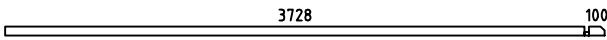
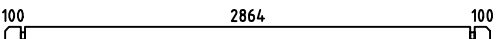
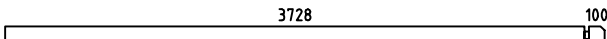
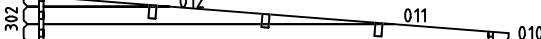
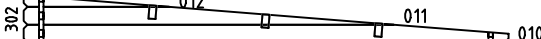
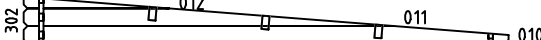
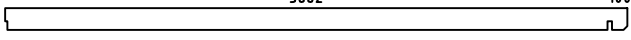
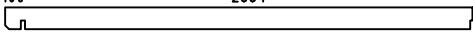
15.07.2024





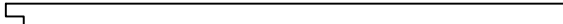

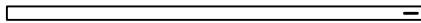
2/6

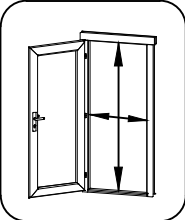
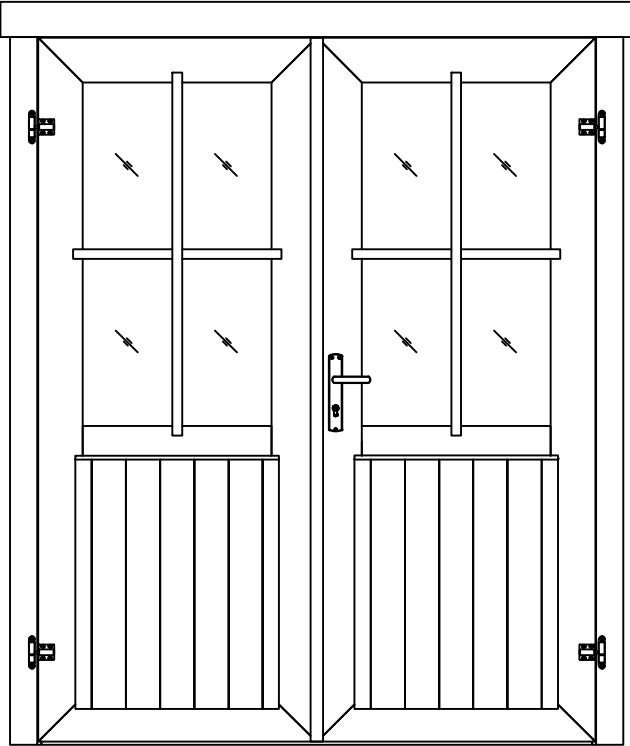

Art. Nr. 2824696 DB

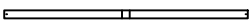
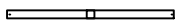

| Pos | 15.07.2024 Piece list - Stückliste - Liste des pièces - Elementi - Stuklijst - Tükítabel Art. Nr. 2824696 5/6 | Q | P (mm) | L (mm) |
|----------------|--|----|-----------|-----------|
| 001 22693 |  | 2 | 28x57 | 808 |
| 002 22694 |  | 32 | 28x114 | 808 |
| 003 1800 |  | 16 | 28x114 | 300 |
| 004 27902 |  | 3 | 28x114 | 3006 |
| 005 27903 |  | 3 | 28x114 | 4004 |
| 006 22696 |  | 1 | 28x57 | 3120 |
| 007 27904 |  | 1 | 28x57 | 3856 |
| 008 22697 |  | 48 | 28x114 | 3120 |
| 009 27905 |  | 15 | 28x114 | 3856 |
| WA-1 27588 |  | 1 | | |
| WB-1 27588 |  | 1 | | |
| WC-1 27588 |  | 1 | | |
| A-PR2 27908 | Roof beam - Dachbalken - Panne de toit - Perlina del tetto - Gordingen / dakbalk - Pärтин  | 3 | 44x146 | 4004 |
| A-PR1 27907 | Roof beam - Dachbalken - Panne de toit - Perlina del tetto - Gordingen / dakbalk - Pärтин  | 3 | 44x146 | 3006 |
| DB 6900 | Roof boards - Dachbretter - Voliges - Perlina per tetto - Dakhout - Katuselaud  | 78 | 90x15.5 | 3200 |
| 27597 | H-profile - H-profilis - Profile H - Profilo ad H - H-profiel - H-profiil  | 1 | 58x90 | 1820 |
| DPL1 27592 | Roofing felt fillet - Dachpappenleiste - Baguette de fixation du feutre bitumeux - Asse per fissaggio guaina bituminosa - Afdeklijst asfaltpapier - Katusepapiilist  | 1 | 15x45 | 3021 |
| DPL2 25870 | Roofing felt fillet - Dachpappenleiste - Baguette de fixation du feutre bitumeux - Asse per fissaggio guaina bituminosa - Afdeklijst asfaltpapier - Katusepapiilist  | 2 | 15x45 | 3220 |
| DPL3 27909 | Roofing felt fillet - Dachpappenleiste - Baguette de fixation du feutre bitumeux - Asse per fissaggio guaina bituminosa - Afdeklijst asfaltpapier - Katusepapiilist  | 1 | 15x45 | 4019 |
| p 35256 | Post - Pfosten - Poteau - Piede registrabile - Stijl - Post  | 1 | 70x70 | 1662 |
| DRV 27910 | Roof edge reinforcement - Dachrandverstärkung - Corniere de renfort de bord de toit - Rinforzo x tetto - Dakrand versterking - Räästatugevdus  | 2 | 15x45 | 3505 |
| KFS-1 2249 | Storm protection - Sturmleiste - Latte anti-tempete - Protezione anti vento - Stormverankering / beveliging - Tormikinnusliist  | 5 | 22x45 | 2050 |
| GL1 27595 | Gable moulding - Giebelleiste - Planche de rive - Finitura per frontale e retro del tetto - Gevellijst - Viululaud  | 1 | 15x120 | 3021 |

| Pos | 18.12.2017 | Piece list - Stückliste - Liste des pièces - Elementi - Stuklijst - Tükítabel 14.94x1850 TUK.2.044.SVP.MX28 SGA+28 | 1/2 | Q | P (mm) | L (mm) |
|--|--|---|---|---|---|-----------|
| Glass size - Glasgröße - Taille de la vitre - Misura del vetro - Glas afmeting - Klaasi mõõt: 502x900 mm | | | | |  1418x1794 mm | |
|  | | | | | | |
| 1 | Upper door jamb - Türrahmen oben - Cadre de porte supérieur - Telaio superiore della porta - Bovendorpel - Ukse ülemine leng | |  | 1 | 66x100 | 1438 |
| 2 | Left door jamb - Türrahmen links - Cadre de porte gauche - Telaio montante sinistro della porta - Linkerstijl deurframe - Ukse vasak leng | |  | 1 | 66x80 | 1850 |
| 3 | Right door jamb - Türrahmen rechts - Cadre de porte droit - Telaio montante destro della porta - Rechterstijl deurframe - Ukse parem leng | |  | 1 | 66x80 | 1850 |
| 4 | Doorstep - Swelle - Barre de seuil - Soglia della porta - Deurdorpel - Lävepak | |  | 1 | 18x18 | 1418 |
| 5 | Connection strip - Deckleiste - Baguette de battement - Profilo verticale della porta - Stulplijst - kokkuvaltsiliist | |  | 1 | 13x32 | 1812 |
| 6 | Georgian bars - Sprossen - Croisillons - La griglia georgiana - Raamverdeling - Petteliistud | |  | 2 | 15x25 | 934 |
| 7 | Georgian bars - Sprossen - Croisillons - La griglia georgiana - Raamverdeling - Petteliistud | |  | 2 | 15x25 | 536 |

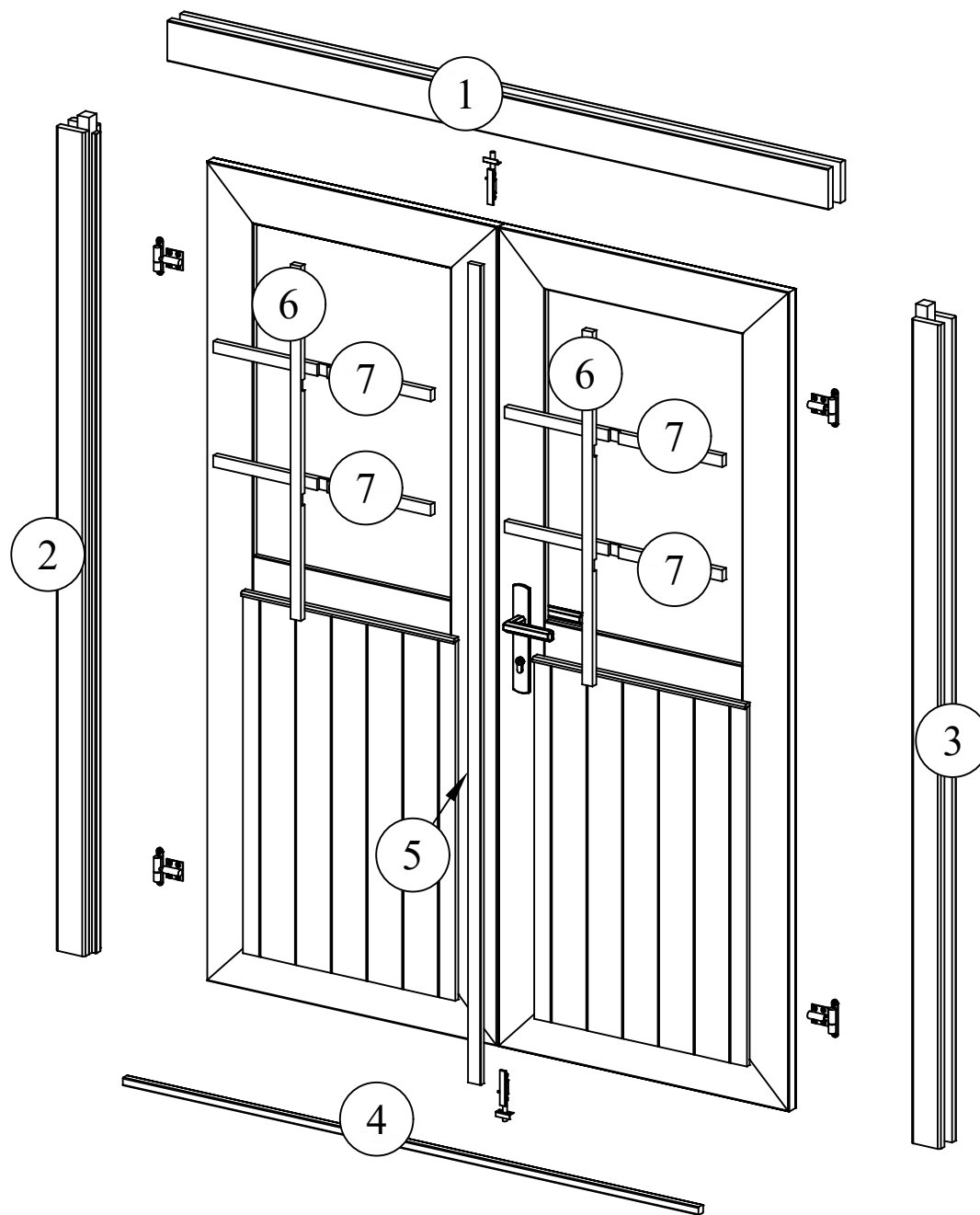

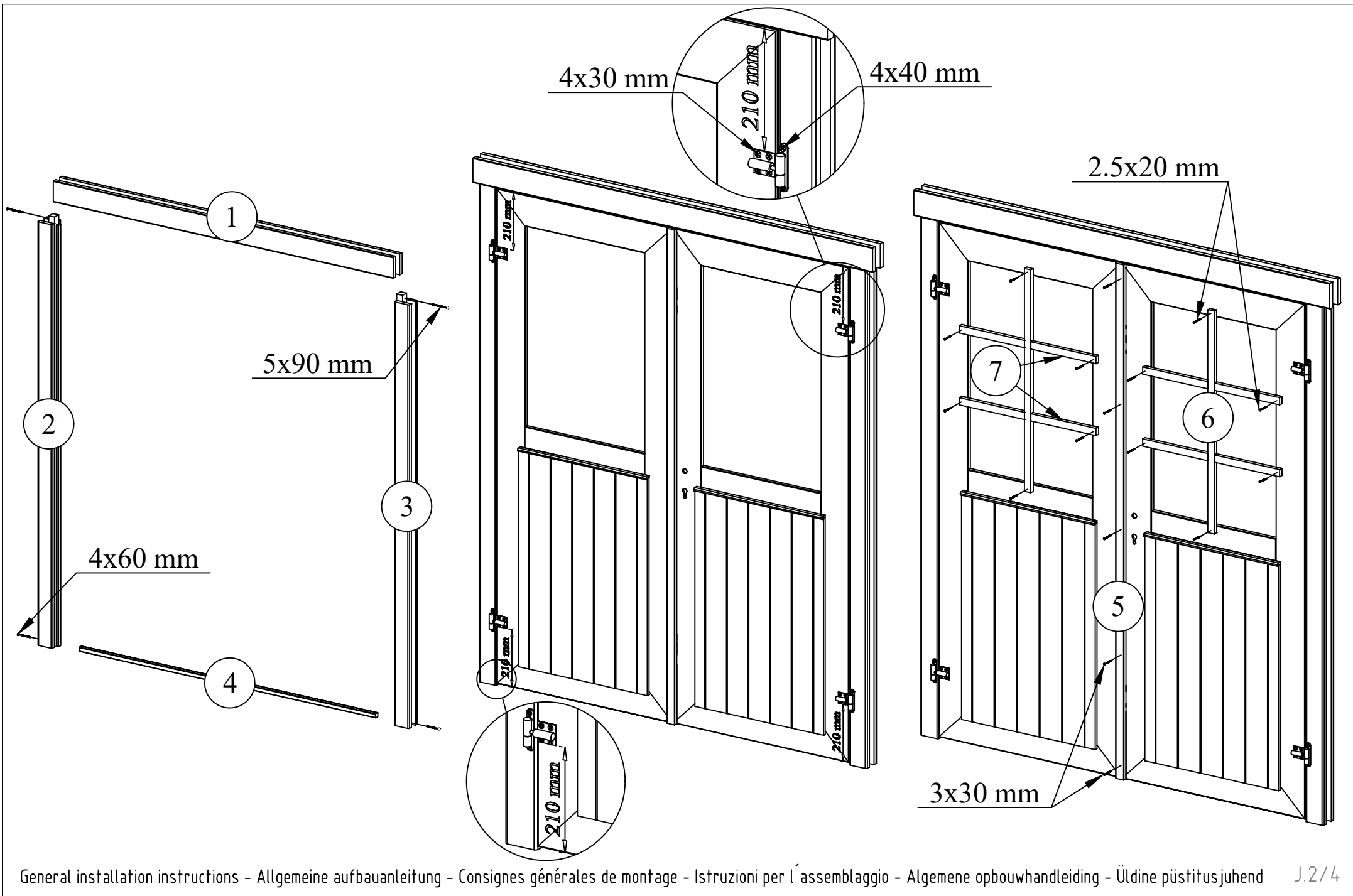

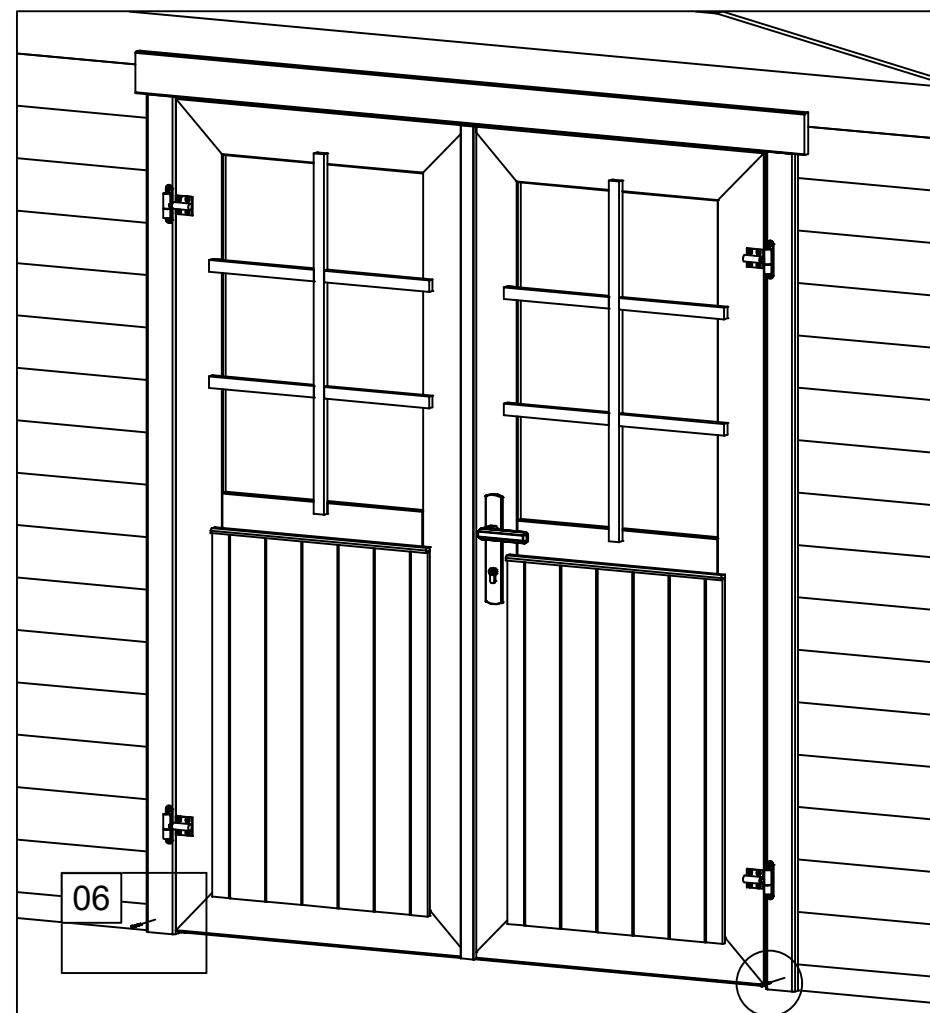
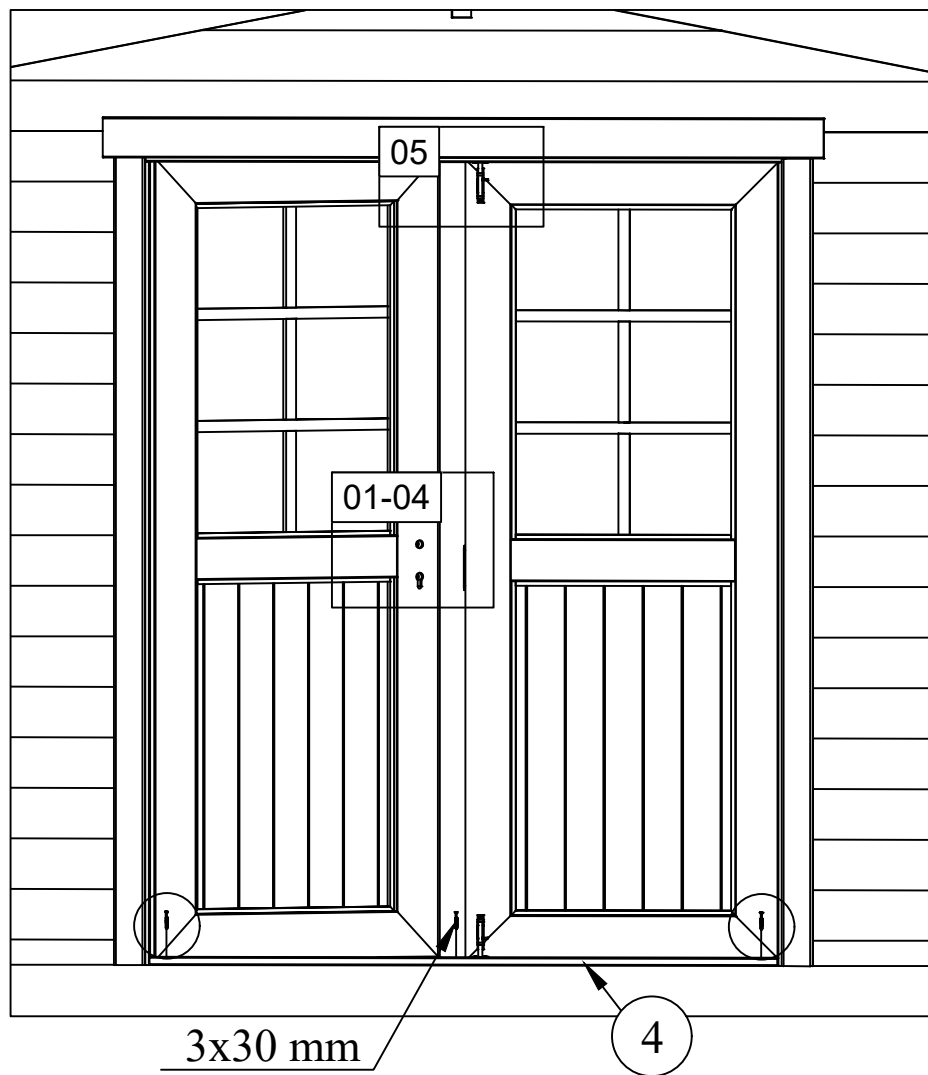

01

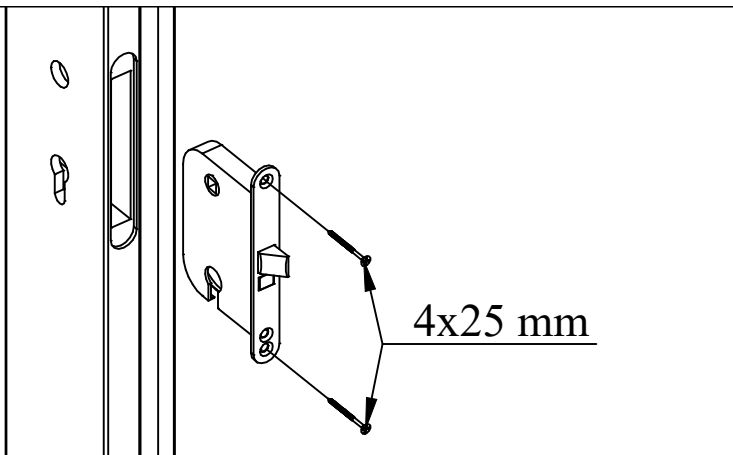

04

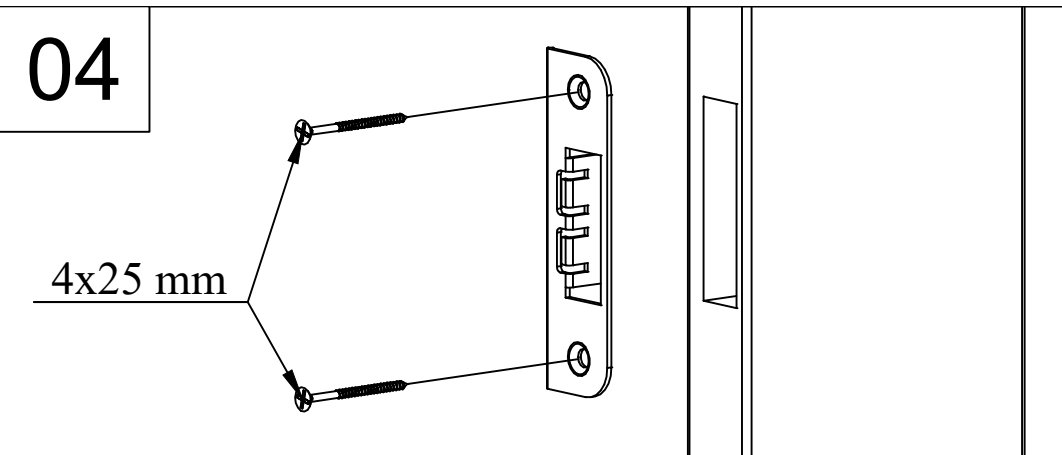

02

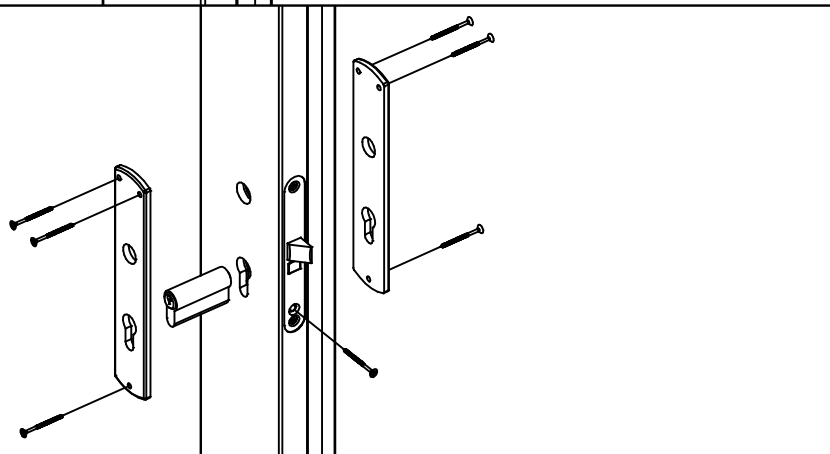

05

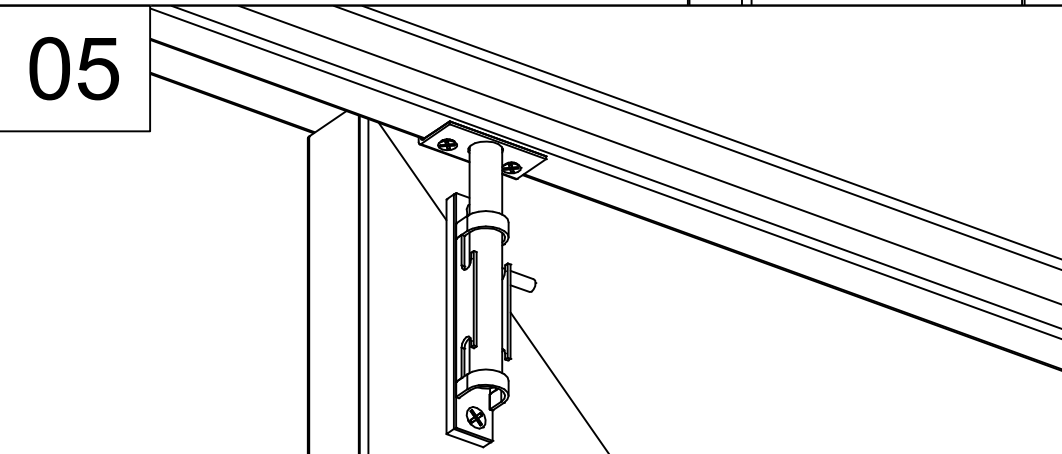

03

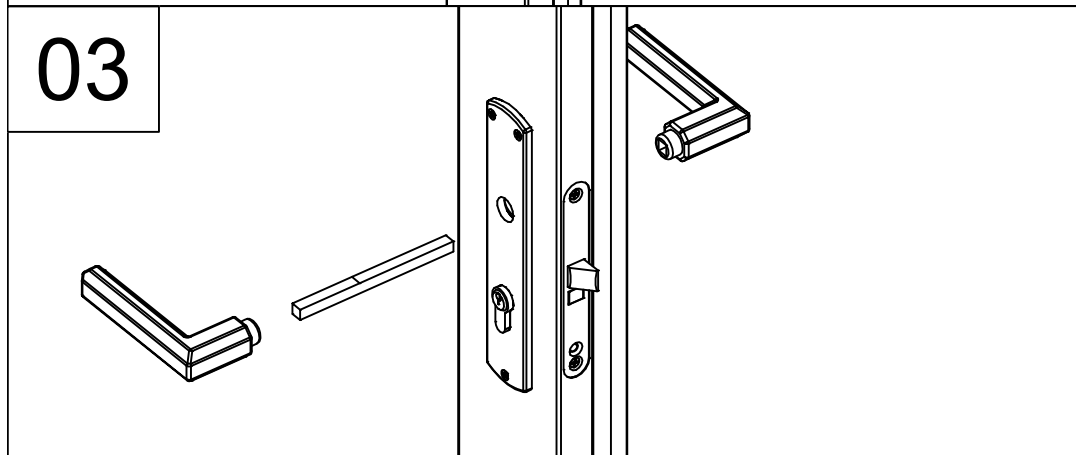

06

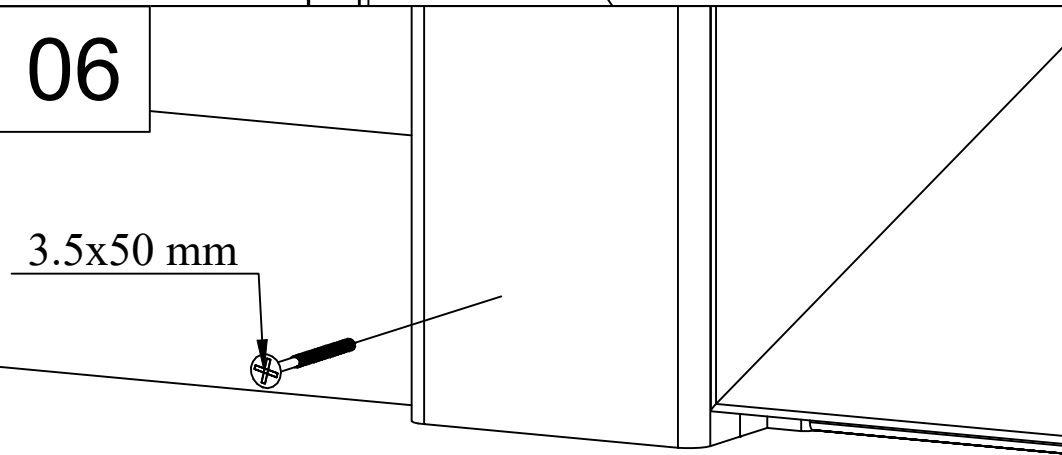

DANCOVER[®]

.com

Contact information

Austria



Belgium



Croatia



Denmark



Estonia

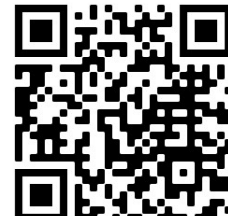

Finland



France



Germany



Ireland



Italy



Latvia



Lithuania



Nederland



Norway

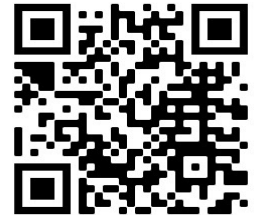

Poland

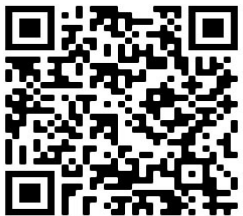

Portugal



Spain



Sweden



Switzerland



UK



For more information please visit: www.dancovershop.com